

**KURSUS KESEDARAN
KAWALAN TUMPAHAN MINYAK
DAN PEMBERSIHAN PANTAI
NEGERI PULAU PINANG**

7-9 NOVEMBER 2000

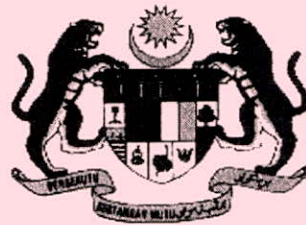

**ANJURAN
JABATAN ALAM SEKITAR
DENGAN KERJASAMA
KERAJAAN NEGERI PULAU PINANG**

**DI
HOTEL SUNWAY
BUTTERWORTH, PULAU PINANG**

IKLAS Bahan Kursus

Tajuk Kursus : Kursus Kawalan Tumpahan Minyak
Dan Pembersihan Pantai Negeri Pulau Pinang

**KURSUS KESEDARAN KAWALAN
TUMPAHAN MINYAK DAN
PEMBERSIHAN PANTAI
NEGERI PULAU PINANG**

**Tajuk:
Senario Tumpahan Minyak
Di Malaysia**

**Oleh:
Encik Hasbullah Zakaria**

**SENARIO TUMPAHAN MINYAK
DAN AKTIVITINYA DI MALAYSIA**

Oleh:
**Jabatan Alam Sekitar
Kuala Lumpur**



ISU-ISU

Isu-Isu
Peralatan Peralatan Mel
Minyak
Tumpahan Minyak

Kelajuan Tumpahan Minyak

Tarikh	Nama Kejadian	Tempat
06 Jan 1973	Kapal MT Shawa Maru (Tumpah 5,000,000)	Selat Singapura
05 April 1979	Kapal MT T. Yamada (Tumpah 70,000,000)	Ujung Selat Singapura
20 Sept 1992	Kapal MT Nagasaki Spirit (Tumpah 1,000,000)	Selangor Melaka
15 Okt 1997	Kapal MT E. L. Jones (Tumpah 1,750,000)	Selangor Singapura
21 Mei 1999	Kapal SS Shin Yusei (Tumpah 1,000,000)	Selangor Singapura

2. Pelan dan Rancangan Tindakbalas

Tarikh	Kejadian
• 23 Jun 1976	• Ketetapan Jenuah Menteri supaya tubuh Rancangan Kontingensi Kawalan Tumpahan Minyak
• April 1984	• SOP melawan tumpahan minyak bersama, Indonesia, Malaysia dan Singapore
• Tahun 1984	• Cooperative Network for Oil Spill Countermeasures in the Lombok, Makassar Straits and Sulawesi
• Tahun 1986	• Pembentukan Rancangan Kontingensi Laut China Selatan
• Tahun 1989	• Penyelarasan Rancangan Kontingensi Kebangsaan
• 9 Okt 1993	• SOP Malaysia - Brunei
• 6 Jan 1994	• ASEAN - Oil Spill Response Action Plan
• Tahun 1994	• Semakan Rancangan Kontingensi Kebangsaan
• Tahun 1999	• Semakan Rancangan Kontingensi Kebangsaan

3. Kursus Kesedaran dan Latihan

Tarikh	Kejadian
• Oktober 1984	• Exercise Melaka
• 23 Sept. 1986	• Latihan Melawan Tumpahan Minyak Bersama, Indonesia, Malaysia dan Singapore
• 29 Julai 1990	• Latihan Melawan Tumpahan Minyak Bersama, Indonesia, Malaysia dan Singapore
• 14 Nov. 1994	• Latihan Tumpahan Minyak Kebangsaan
• Oktober 1994	• Kursus Kawalan Tumpahan Minyak
• 20 April 1999	• Latihan Melawan Tumpahan Minyak Bersama, Indonesia, Malaysia dan Singapore
• 13 Julai 1999	• Kursus Kawalan Tumpahan Minyak
• 11 Okt. 1994	• Kursus Kawalan Tumpahan Minyak

4. Pengkalan Peralatan

Tarikh	Kejadian
• Sejak 1987	Pengkalan Kerajaan <ul style="list-style-type: none"> • Di Jabatan Laut, Kelang • Di Jabatan Laut, Johor Bahru • Di Jabatan Laut, Pulau Pinang • Di Jabatan Laut, Labuan • Di Jabatan Laut, Kuching
• 4 Dis. 1993	Pengkalan Swastika Minyak <ul style="list-style-type: none"> • Kerteh • Port Dickson • Labuan • Miri • Kuching
• 6 Jun 1994	Pengkalan Swasta <ul style="list-style-type: none"> • Petroleum Association of Japan (PAJ) • Di Pelabuhan Kelang

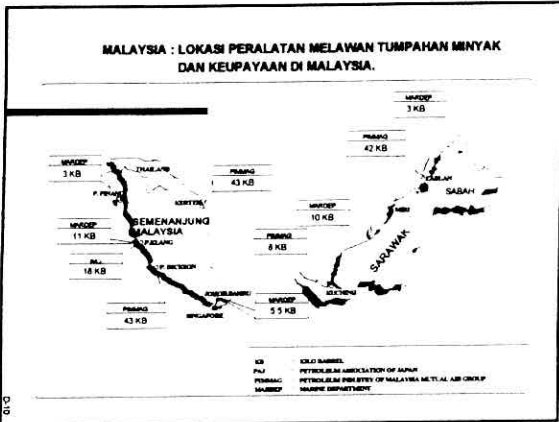

5. Mekanisma Tuntutan

Tarikh	Kejadian
• Sejak 1980	Jabatan Alam Sekitar mempunyai Tabung Akaun Amanah Perlindungan dan Pemuliharaan Kualiti Alam Sekitar yang menerima hasil sumbangan dari gantirugi-pampasan dan tumpahan minyak yang berlaku.
• 11 Feb 1981	Satu Tabung Pusingan antara 3 negara telah ditubuhkan antara Negara Indonesia, Malaysia dan Singapura dengan wang pendahuluuan dari Persatuan Bukan Kerajaan Negeri Jepun. Wang dari tabung pusingan ini hanya boleh dipinjam dan dikembalikan apabila menerima gantirugi dari pihak pencemar.
• 6 April 1995	Kerajaan Malaysia melalui Kementerian Pengangkutan dan Jabatan Laut telah menandatangani konvensyen antarabangsa CLC 1969 dan FUND 1971, sebagai satu mekanisme membezakan tuntutan dan pampasan tumpahan minyak akibat kapal tangki.

6. Konvensyen Antarabangsa

Tarikh	Kejadian
• 01 Mei 1977	International Convention for the Prevention of Pollution from Ship 1973 as modified by protokol of 1978 (MARPOL 73/78)
• 30 Oktober 1997	Convention on Oil Pollution Preparedness, Response and Co-operation, 1990
• 06 April 1997	Civil Liability Convention 1969 dan International Oil Pollution Compensation Fund, 1971

7. Garispanduan, Protokol dan Ketetapan

- | Tarikh | Kejadian |
|---------------|---|
| • 1984 - 1987 | Satu projek dibawah COBSEA iaitu projek Cooperative Research On Oil Dispersant Toxicity in East Asian Seas Region telah dijalankan. Berpanduan protokol ini Jabatan Alam Sekitar telah menyediakan satu garispanduan penggunaan dispersant di perairan Malaysia. Hanya dispersant yang melepasi ujian toksisiti dan dituluskan oleh Jabatan Alam Sekitar sahaja boleh digunakannya. |
| • April 1984 | Pembentukan Protokol ujian "Oil Dispersant". |
| • 9 Mac 1999 | Jabatan Alam Sekitar telah mengeluarkan satu arahan dan garispanduan kepada semua industri minyak, kemudahan pengendalian minyak dan pelabuhan-pelabuhan supaya menyediakan plan kontingensi peringkat 1 (Tier 1) dan pembaikan peralatan tangkapan minyak. |

7. Garispanduan, Protokol dan Ketetapan (Samb.)

- | Tarikh | Kejadian |
|---------------|--|
| • 20 Okt 1995 | Pada mesyuarat MEXCOE ke 11 di Kota Kinabalu, semua negeri bersetuju untuk menubuhkan satu Jawatankuasa Pembersihan Pantai Peringkat Negeri yang akan dipengerusikan oleh Setiausaha Kerajaan Negeri. |
| • 20 Okt 1998 | Pada mesyuarat MEXCOE ke 16, JAS telah diminta untuk menyediakan satu garispanduan bagi membantu Kerajaan Negeri-negeri berkuasa tempatan memperkemaskan tindakan pembersihan pantai. |
| • 20 Okt 1999 | Pada mesyuarat MEXCOE ke 17, JAS telah menyediakan garispanduan untuk penyediaan plan tindakan pembersihan pantai dan pelupusan sisa berminyak untuk dijadikan panduan kepada kerajaan negeri memperkemaskan tindakan pembersihan pantainya. |

**SELESAI
TERIMA KASIH**

IKLAS Bahan Kursus

Tajuk Kursus : Kursus Kawalan Tumpahan Minyak
Dan Pembersihan Pantai Negeri Pulau Pinang

**KURSUS KESEDARAN KAWALAN
TUMPAHAN MINYAK DAN
PEMBERSIHAN PANTAI
NEGERI PULAU PINANG**

**Tajuk:
Regim Dan Kaedah Tuntutan
(Avidence Gathering and
Documentation)**

**Oleh:
Encik Rosid Musa**



LIABILITY
AND
COMPEMSATION

There is a tide in the affair of men, which,
taken at the flood, leads on to fortune;
Omitted, all the voyage of their life is bound in shallows and
miseries
- Shakespeare

THE CONVENTIONS

- the International Convention on Civil Liability for Oil Pollution Damage, 1969;
■ adoption : 29 November 1969; Entry into force : 19 June 1975.
- International Convention on the Establishment of an International Fund for Compensation for Oil Pollution Damage, 1971;
■ adoption : 18 December 1971; Entry into force: 16 October 1978.

AIMS

- The aim of CLC is to ensure that adequate compensation is available to persons who suffer oil pollution damage resulting from maritime casualties involving oil-carrying vessels.
- The purposes of the Fund Convention is to provide compensation for pollution damage to the extent that the protection afforded by the 69 CLC is inadequate.

THE VOLUNTARY INDUSTRY SCHEMES

- TOVALOP (Tanker Owners Voluntary Agreement concerning Liability for Oil Pollution).
- CRISTAL (Contract Regarding a supplement to Tanker Liability for Oil Pollution).
- These agreement ceased on 20th February 1997.

Merchant Shipping (Oil Pollution) Act 1994

- ACT 515, 1994 was gazetted on 24th February 1994.
- Enter into force on 6th April 1995.
- With the aim to enforce 1969 CLC and 1971 Fund in Malaysia and Malaysian registered ships wherever they are.

JABATAN LAUT

Application of ACT 515/94 vis-a-vis CLC 69

- CLC applies to all ships carrying oil in bulk as cargo.
- definition of oil is persistent oil such as crude oil, fuel oil, heavy diesel oil, lubricating oil and waste oil, whether carried on board a ship as cargo or in the bunkers of such a ship.
- 'Pollution damage' means loss or damage caused outside the ship carrying oil by contamination resulting from the discharge or escape of oil from the ship, whenever such escape or discharge may occur; includes the cost of preventive measures and further loss or damage caused by preventive measures.

Continue

- Ship carrying more than 2000 tons of oil are required to maintain insurance.
- does not apply to war ship or state owned vessel for non commercial service.
- Applies in the territorial waters only.

Application of A515/Fund 71

- Any person who receives oil by sea of more than 150,000 tons annually shall make contribution to the Fund
- 'oil' means crude oil and fuel oil
- applies in the territorial waters

CLC Protocols

- The Protocol of 1976; adopted on 19 November 1976, enter into force on 8-4-81
- The Protocol 76 provides for unit of account based on SDR instead of 'Poincare Franc'
- The Protocol of 1984 with the intention to increase the maximum liability limit
- The Protocol 84 is not enter into force and it is superceded by 1992 Protocol

FUND Protocols

- The Protocol of 1976; adopted on 19 November 1976,
- The Protocol 76 provides for unit of account based on SDR instead of 'Poincare Franc'.
- The Protocol of 1984 with the intention to increase the maximum liability limit up to US\$208 million
- The Protocol 84 is not enter into force and it is superceded by 1992 Protocol

Liability Limit and maximum compensation

- Under CLC 69 owner can exercise to limit of his liability according the tonnage of the ship i.e. 133SDR (2,000 francs) per net tonnage, but not to exceed 14 million SDR (210 million francs)
- Owner shall not be entitled to avail himself of limitation if the incident occurred due to his actual fault or privity.

Continue

- Maximum compensation payable by Fund 71 is 60 million SDR (900 million francs) i.e. the Fund's maximum liability is 46 million SDR
- Article 5 of the Fund Convention provides to indemnify the owner for a portion of his liability under CLC 69 up to 8.3 million SDR

Contributing oil received in member states

- 1996 : 1.2 billion tonnes; 1997 : 316.5 million tonnes
- Malaysia (1996) : 16.4 million tonnes; 1997 : 17.2 million tonnes

CLAIMS UNDER CLC 69

- Claims for compensation for pollution damage may be brought directly against the insurer
- No claims can be made against the servants or agents of the owner
- the owner may be exonerated from liability:
 - pollution damage resulted from an act of war, etc.
 - damage caused by third party
 - caused by negligence or wrongful act of the government.

CLAIMS UNDER FUND 71

- Claims for compensation for pollution damage may be brought against the 1971 Fund.
- Compensation payable in respect of claims fulfilling the criteria for admissibility laid down in the 69 CLC and 71 Fund.
- the Fund does not pay if:
 - pollution damage in non-member state
 - damage resulted from the act of war
 - the damage was not resulted from 'ship'

1971 Fund 'pays' when:

- owner is exempted from liability under the 69 CLC
- owner is financially incapable
- damage exceeds the limit of owner's liability

Who is entitled to compensation?

- Anyone who has suffered pollution damage:
 - individuals,
 - companies,
 - local authorities
 - states
 - etc,

Within what period should a claim be made?

- As soon as possible
- within 3 years but not later than 6 years

Content of a claim

- basic information:
 - name and address of the claimant
 - identity of the ship involved
 - date, place and specific details of the incident
 - type of pollution damage sustained
 - the amount of compensation claimed
- claim presentation
 - it is essential that supporting documentation is submitted too

Admissible Claims

- pollution damage and preventive measures
 - any expense/loss must actually have been incurred
 - any expense must relate to measures which are deemed reasonable and justifiable
 - expense / loss or damage caused by contamination
 - link of causation between the expense/loss or damage and contamination caused by spill
 - has suffered quantifiable economic loss
 - appropriate documents and other evidence

Continue

- Clean-up operations and property damage
 - cost of personnel and hire or purchase of equipment and materials
 - loss/damage of property caused by measures to minimize pollution
 - salvage and preventive measures
 - disposal of collected material
 - property damage
 - cost of studies
 - fixed costs and additional costs

Continue

- Consequential loss and pure economic loss
 - Consequential loss e.g. loss of income (fisherman loss of income as a result of his net is polluted)
 - pure economic loss i.e. loss of earnings sustained by persons whose property has not been polluted (e.g. hotelier, restaurateur, fishermen etc.)

Continue

- Environmental damage
 - costs for measures taken to reinstate the marine environment after an oil spill under conditions
 - The cost of measures should be reasonable
 - the measures should be appropriate and offer a reasonable prospect of success

1992 Conventions

- Protocol of 1992 to 1969 CLC
- Protocol of 1992 to 71 Fund
- Aims:
 - increase level of liability limit and maximum compensation
 - greater application
 - modify the entry into force requirements

1992 Conventions (Continue)

- 1992 CLC
 - adopted : 27 November 1992
 - Entry into force : 30 May 1996
- 1992 Fund
 - adoption : 27 November 1992
 - Entry into force: 30 May 1996

1992 Conventions (Continue)

- Geographical scope
 - extended to EEZ
- apply to preventive measures even when no spill occurs
- apply to spills of bunker oil from unladen tankers
- deprivation of owners of the right to limit his liability is less severe

1992 Conventions (Continue)

- Claims can be made against registered owner
- The Fund does not indemnifies ship owner
- Maximum amount of contribution by single state will not be greater than 27.5 % (in the case of Japan)
- New structure of limit of liability and increase amount of maximum compensation payable

1992 Conventions (Continue)

- 1992 Fund
 - adoption : 27 November 1992
 - Entry into force: 30 May 1996

1992 Conventions (Continue)

- 1992 CLC: limitation of liability
 - Ship not exceeding 5000 GT : 3 million SDR
 - ship between 5000 GT and 140000 GT: 3 million SDR + additional 420 SDR per GT
 - ship of more than 140 000 GT : 59.7 million SDR
- 1992 Fund : maximum payable compensation
 - 135 million SDR (including the sum actually paid by the owner or his insurer)

JABATAN LAUT

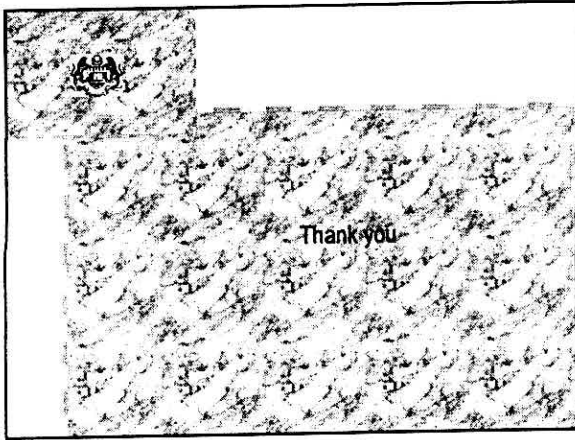

IKLAS Bahan Kursus

Tajuk Kursus : Kursus Kawalan Tumpahan Minyak
Dan Pembersihan Pantai Negeri Pulau Pinang

**KURSUS KESEDARAN KAWALAN
TUMPAHANMINYAK DAN
PEMBERSIHAN PANTAI
NEGERI PULAU PINANG**

**TAJUK:
Penilaian Situasi
(Surveillance)**

**Oleh:
Encik Maarof Sanif**

SITUATION EVALUATION AND RESPONSE OPTIONS

1.0 Identification of Source and Incident Details

In the case of major oil spills, it will not usually be difficult to identify the origin of the spilled oil and to obtain information about its characteristics.

Smaller oil slicks in harbours, anchorages and coastal waters, whose origins are unknown, may result from accidents or operational discharges. Unless the incident is witnessed, identification of the source is difficult; however, chemical analysis can assist in such identification.

First information about an incident may be received from any one of a number of sources, including the general public. Attempts must be made to learn as much as possible about the incident, to identify those responsible for the spill, to monitor developments and to pass information promptly as it is received to the government agencies responsible for dealing with the oil spill. The type of information required is outlined in *Section II - Contingency Planning* of the *Manual on Oil Pollution*.

Should an oil spill originate from an offshore installation, the operators of the installation will normally be the source of information. Usually, information about the type of oil together with an estimate of quantity will be readily available.

2.0 Prevention or Reduction of Further Spillages

Should a vessel have been involved in an accident leading to an oil spill, the first and most important response action is, if possible, to prevent further spillage. This must be given the utmost priority by all concerned.

The master of the ship should be asked to identify the damaged tanks and, if possible, to transfer the oil contained in those tanks to any space available. This may be difficult if, for example, the bottom of the tank concerned is damaged.

Consideration should be given to transferring some or all of the oil to another ship or ships to stop the outflow of oil and to allow the vessel to proceed to a suitable port for complete discharge. This is a job that needs experience, expertise and probably special pumps and other equipment which will usually be provided by the ship owner, cargo owner or salvage company under the supervision of the appropriate government agency. The whole operation will have a much greater chance of success if it can be conducted under calm water conditions and this possibly means moving the damaged ship to shelter. The overall risk is thereby reduced, even if the operation takes place much closer to the shore than it otherwise would.

Should the vessel be aground, in such a position that another ship cannot get alongside, it may be possible to use a shallow draught barge or floating storage tank to remove part of the oil cargo. Another possibility is the use of floating hoses, to transfer the oil to a ship in deeper water. Such an operation will call for the expertise and equipment only likely to be found in a major salvage company, tanker operator or government agency.

Additional information on the foregoing may be found in *Section III - Salvage* of the *Manual on Oil Pollution* and the ICS/OCIMF publication *Peril at Sea and Salvage - A Guide for Masters*.

3.0 Aerial Surveillance, Including Remote Sensing

Information concerning the movement of oil which has already been spilled is of vital importance in choosing response options. Such information might be available from the prediction methods described in Chapter 3. More reliable information can be obtained from visual sightings and photographs, and the best way to obtain these is from an aircraft. Surveillance from the air should be conducted by trained observers who can identify oil on the water surface visually or by use of electronic sensors as described in paragraphs 5.3.6 and 5.3.7. Other factors permitting, continuity of observation by the same observers is likely to give more reliable information.

The purpose of aerial surveillance is:

- to determine the size, quantity and location of the spill;
- to determine the movement of the oil;
- to note changes in the appearance and distribution of the oil over time;
- to forecast which marine and coastal resources or areas are under threat; and
- to observe and report on effectiveness of response measures.

Suitable aircraft, which may be fixed-wing aircraft or helicopters, should have good all-round visibility and appropriate navigational aids and communications equipment. If dedicated surveillance aircraft are not readily available, consideration should be given to use of suitable government, commercial or private aircraft. National regulations may demand multi-engined aircraft for long-range operation over the sea; safety is paramount and the pilot must be consulted on all aspects of the proposed flight.

If a large sea area has to be searched, a flight plan must be prepared in advance using all available information to reduce the search area and the prediction methods previously described in Chapter 3.

Various search patterns have been devised for search and rescue, and these may be used for aerial surveillance of oil spills (see *IMO Merchant Ship Search and Rescue Manual (MERSAR)*). The most likely pattern to be used is the ladder search, carried out across the direction of the wind. Another factor to take into account is the direction of the sun, which may make observation of the sea surface difficult. Visual surveillance is usually conducted from an altitude of 300m – 500m, but at a lower altitude to confirm details of oil sighted.

To improve the detection and investigation of oil slicks at sea, both from a distance and under unfavourable light conditions, various remote sensing devices are available for fitting to a dedicated aircraft. These currently include:

- Side-looking airborne radar (SLAR)
- Infrared line scanner (IRLS)
- Ultraviolet line scanner (UVLS)
- Low light level television systems
- Microwave radiometry

Such systems include integrated navigation and recording equipment. This is already a proven system capable of investigating an oil spill and thereby improving control of oil spill response. However, the full potential of this equipment has yet to be developed.

Remote sensing equipment using other techniques is being developed to improve the quantification and characterization of the oil. These include laser fluorimetry and airborne and satellite-mounted synthetic aperture radar.

Apart from the technical skill needed to interpret the information gathered by remote sensing methods, the command and control organization needs to be able to receive and take advantage of this additional source of information.

4.0 Assessment of the Threat

As information about an oil spill is received the response organization must assess the threat it presents before deciding on appropriate action.

Factors to be considered in assessing the threat include:

- the size of the spill and the likelihood of further spills;
- the type or types of oil – physical and chemical characteristics;

- the weather including wind direction and force, sea state, sea temperature, and tide or current;
- the position of the spill in relation to marine and coastal resources;
- the likely movement of the spill; and
- areas and resources at risk, such as:
 - fisheries interests;
 - birds and other wildlife;
 - areas of particular environmental significance;
 - industrial users of seawater, e.g. power stations;
 - desalination plants;
 - amenity beaches;
 - yachting and other recreational facilities

5.0 Spill Response Options and Their Limitations

Responsibility for clean-up may lie with the national authorities, the polluter, or elsewhere as set out in the contingency plan. Measures to deal with oil spills have severe limitations and imperfections. Given unfavourable circumstances, there is a real possibility that no effective response will be available and the oil will have to be left to respond to natural forces.

In deciding what action to take, if any, the relative importance of the various resources at risk should be considered, taking account of the likely success of available response measures at sea and the difficulties of the subsequent shore-line clean-up. Conflicting views may be given in an emergency about the importance of different resources and decision making will be easier if an environmental sensitivity survey has been conducted in advance. The relative order of importance of different fish and bird breeding seasons, and the holiday season. These issues are dealt with in more detail in *Section II - Contingency Planning of the Manual on Oil Pollution*

The possible response options are:

- no action other than monitoring the oil slick. This might be the proper decision if the oil is not moving shorewards, or if no important resources are threatened, or if the oil is breaking up naturally, or if conditions are such that positive response options are not practicable;
- containing or recovering the oil at sea. This is often the preferred option for both environmental and socio-economic reasons. The advantages and limitations of these techniques are described more fully in Chapter 6;
- Chemical dispersion at sea. In some circumstances the appropriate response will be to enhance the dispersion of oil from the surface into the water column by the

application of dispersant chemicals. The advantages and limitations of this technique are discussed in Chapter 7;

- **Shore-line clean-up.** Given unfavourable circumstances, it is likely that some oil will come ashore and shore-line clean-up will be necessary. Practical advice on shore-line clean-up is to be found in Chapter 8;
- **Combination of response options.** A combination of response options will usually be needed in large spill. Only by having a good understanding of the advantages and limitations of the different options can responsible officials make the best possible decision.

IKLAS Bahan Kursus

Tajuk Kursus : Kursus Kawalan Tumpahan Minyak
Dan Pembersihan Pantai Negeri Pulau Pinang

**KURSUS KESEDARAN KAWALAN
TUMPAHANMINYAK DAN
PEMBERSIHAN PANTAI
NEGERI PULAU PINANG**

TAJUK:
**Pengenalan kepada peralatan
kawalan tumpahan minyak
secara mekanikal
dan kimia**

Oleh:
Encik Maarof Sanif

PRINCIPLES OF BOOMING

1.0 General Use of Boom

The first step in responding to an oil spill is to confine the spill to the source. The purpose of confinement or containment is not only to localise the limit of the area of the spill but also to concentrate oil on water surface to facilitate recovery operations.

An oil boom is a mechanical barrier that extends above and below water surface to contain and concentrate spilled oil for recovery or to divert its flow. Booms are generally used in one of three ways:

- to enclose the oil to facilitate recovery operation;
- to protect specific areas which are environmentally or economically sensitive to oil pollution; and
- to divert the oil to areas where recovery is possible.

2.0 Components of an Oil Boom

Booms normally consist of the following basic components:

- a means of floatation (air or buoyant materials);
- a freeboard section that extend above the water surface;
- a skirt extending in the water column; and
- a longitudinal tension member.

3.0 Type of Booms

Booms are usually grouped into the following three groups:

3.1 Solid Floatation

The floatation consists of buoyant material such as plastic foam, the skirt is made of oil and water resistant fabric ballasted along its lower edge. To facilitate handling, these booms are usually supplied in 15 meters to 20 meters length which are joined by connectors.

The advantage of this type are that inflation is not necessary and minor damage may not effect buoyancy. The disadvantages are that it requires large storage space and is susceptible to deformation during storage.

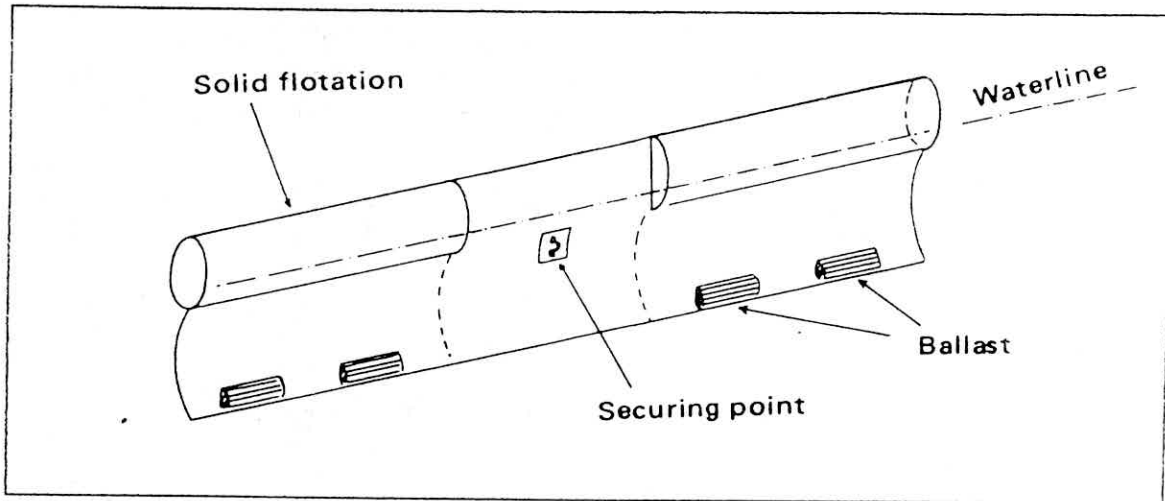

Figure 6 - Solid flotation boom

3.2 Air Inflatable

These boom consist of inflatable air chamber or tubes. In most cases the air is supplied from a low pressure blower but some inflatable booms contain internal spring and non-return valves which permit self inflation. The skirt is made of oil and water-resistant fabric. Some large inflatable booms have independent buoyancy to keep them afloat during deployment and inflation.

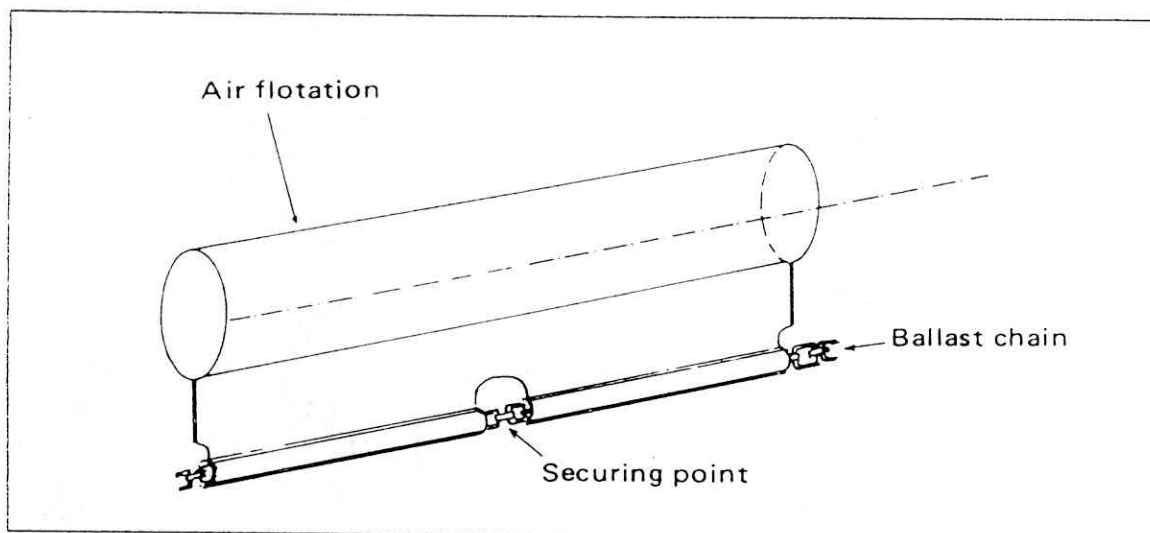

Figure 7 - Inflatable boom

Floating/submerging booms have a similar structure but usually employ longer length and fewer connections. These are used in fixed locations such as at oil terminals and, when not in use, are deflated and rest on the sea bed.

The advantages of an inflatable boom are that it has good wave following characteristic and requires relatively little storage space. The disadvantages are that unless self-inflatable, it takes time to deploy and inflate and rips and tears can cause loss of buoyancy.

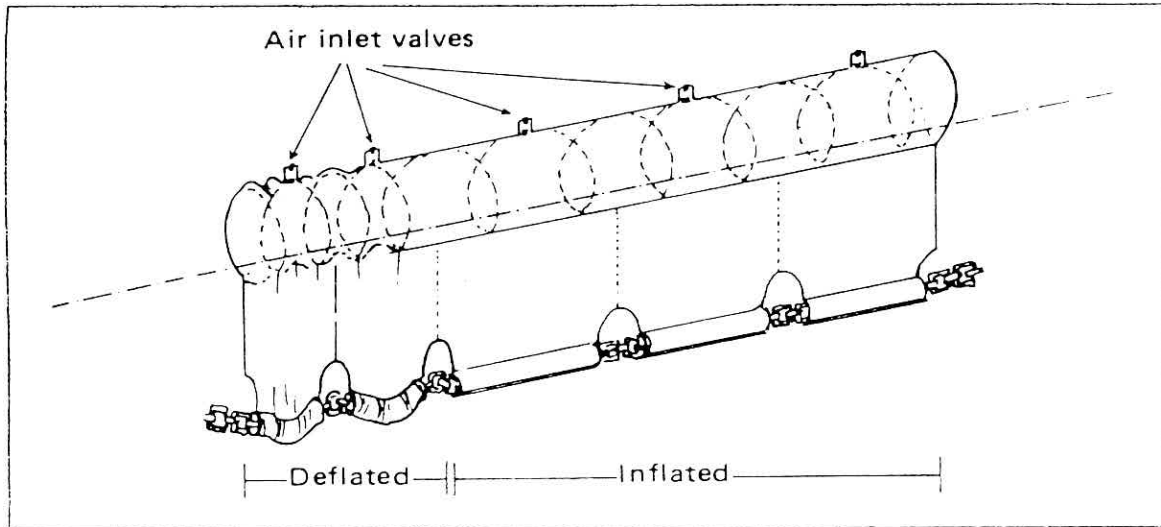

Figure 8 - Self-inflating boom

3.3 Fence boom

A fence boom consists of a single sheet of material which constitutes both freeboard and skirt; floats and ballast weights are attached at intervals

The advantages of this boom are similar to those of the solid floatation type and in addition it requires less storage space. The disadvantages are that long span of the boom tends to lay over under the influence of current or strong winds.

Sea and weather conditions are of great effect to the performance of an oil boom. Therefore boom must be flexible enough to ride the surface of wave and sufficiently rigid to retain oil.

The size and length of boom sections are largely determined by the intended use. Offshore booms are larger and more difficult to handle than inshore booms as they must withstand much more severe sea and weather conditions.

4.0 Performance and Limitations

A good boom should be able to meet the following requirements:

- able to contain and retain as much spilled oil as possible;
- strong and reliable;
- easy to deploy, recover, clean and store;

A boom's performance is very much effected by wind, waves, swells and current. Generally, a boom cannot contain oil effectively when placed at right angles to a current speed in excess of 0.7 knots. Current of greater speed than 0.7 knots may cause droplets to shear from the underside of the contained slick and oil to flow down the face of the boom. To overcome this problem the boom may be placed at an angle to the current

Wind and wave motion are other factors that can lead to boom failure. Strong and gusty wind may cause the boom to move back and forth over the water allowing oil loss through splashing over the top. Long swells decrease the efficiency of oil boom as it cause submergence or oil to roll over the boom.

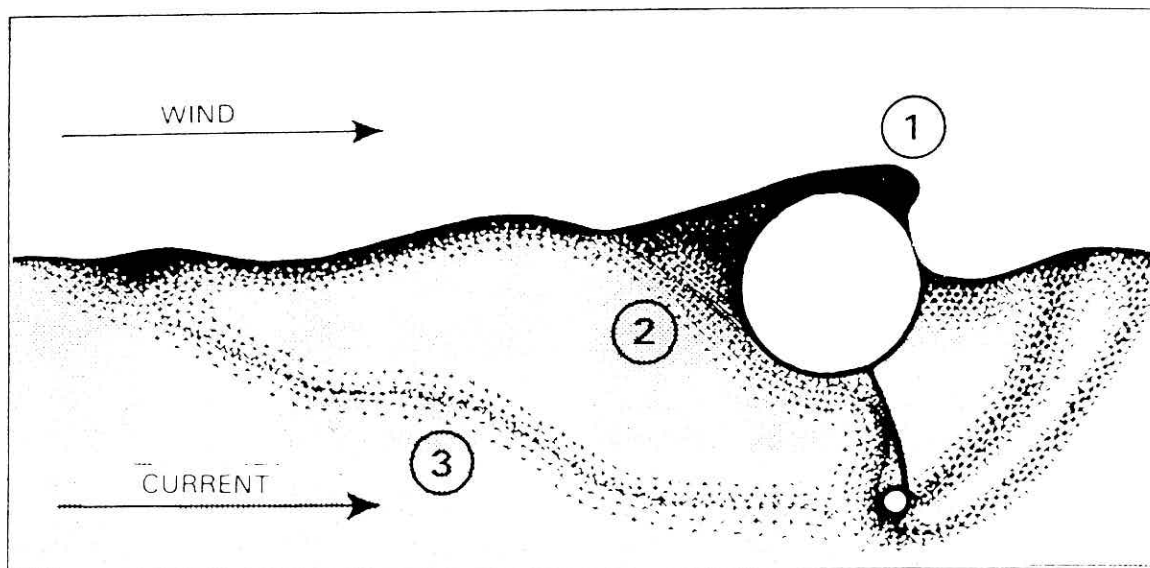

1. Splashover by wave action
2. Flow down the face of the boom
3. Droplet sheared from the underside of the contained slick

Figure 9 - Escape of oil from a boom

5.0 Deployment of Boom

The optimum deployment of a boom will depend on weather conditions, sea state and other factors. The following are typical deployment methods:

5.1 Encircling

This method may be employed in the early stage of spill control when the discharge rate is low and the effect of wind and current are not significant. The boom is deployed around the spill leaving a limited opening for the entry of work boats, if necessary. The length of the boom for this application generally needs to be at least three times the length of the object to be encircled. If the source of the spill is a shore facility, the shore-line may constitute a part of the encircling barrier or when it is a ship, the hull may constitute a part of the barrier. This deployment is employed primarily in calm or sheltered sea areas.

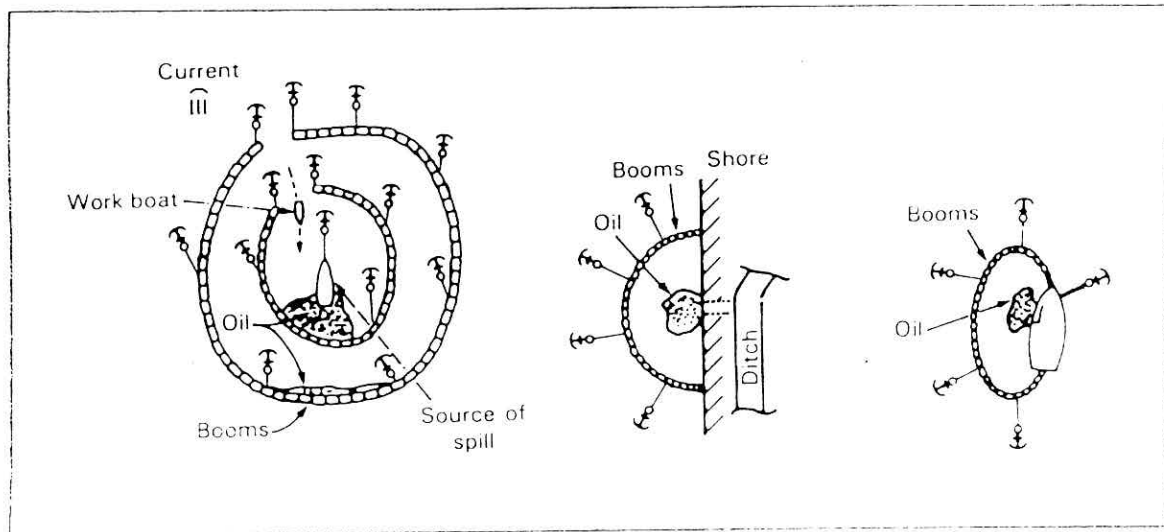

Figure 10 - Encircling

5.2 Waylaying

This method of deployment is used for large spills where sufficient length of boom are not available, or where encircling is difficult due to wind and current. Booms are laid at some distance from the source of spill to intercept the approaching oil. In tidal waters, another set of booms may be laid on the other side of the source in anticipation of a reverse of the current.

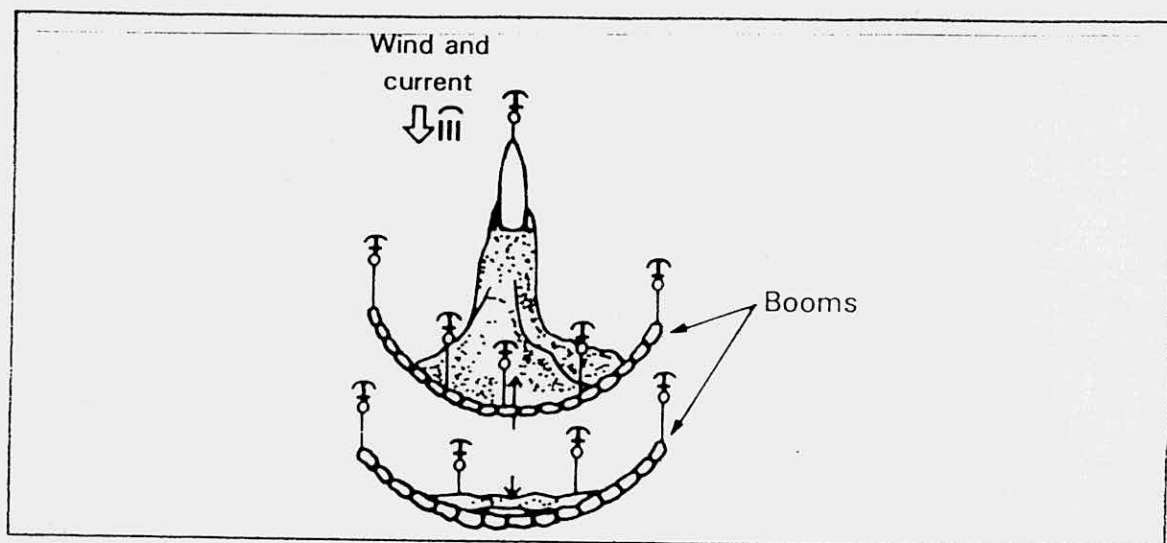

Figure 11 - Waylaying

5.3 Deployment in Channels and Rivers

The spreads of oil in a narrow channel or river may be prevented by laying booms at an angle, depending on the current velocity. A limited opening may be provided in the center of the configuration to permit passage of vessel traffic.

Care must be taken to prevent the oil from escaping from the connections at the shore mooring points during all stages of the tide.

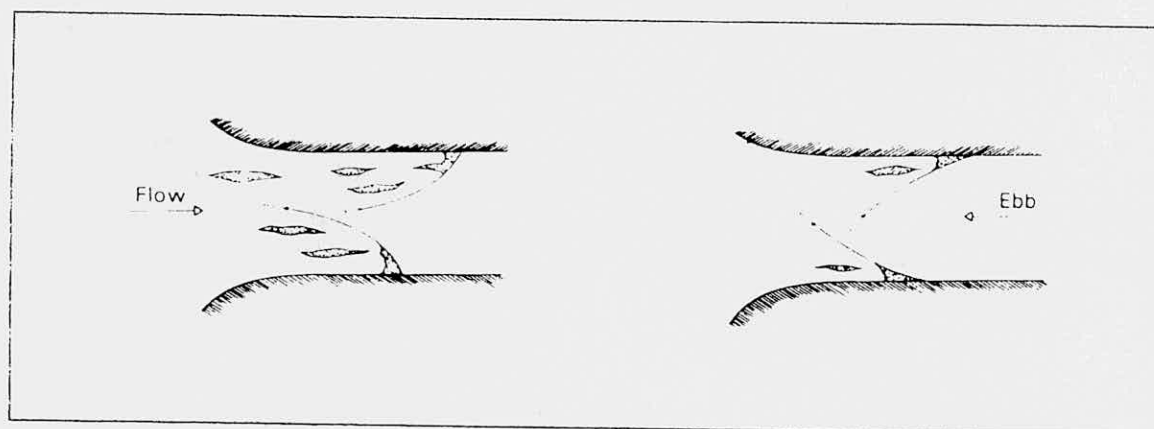

Figure 12 - Staggered boom configuration across a channel

5.4 Deflection Deployment

If spilled oil cannot be contained at the scene of an incident, it may be deflected away from sensitive areas. It is also sometimes possible to deflect oil to a

carefully chosen site from where recovery may be easily accomplished. Again, deflection is achieved by laying the boom at an angle to the direction of the current flow. Care must be exercised so that the deflection of spilled oil does not make matters worse, particularly during night-time operations.

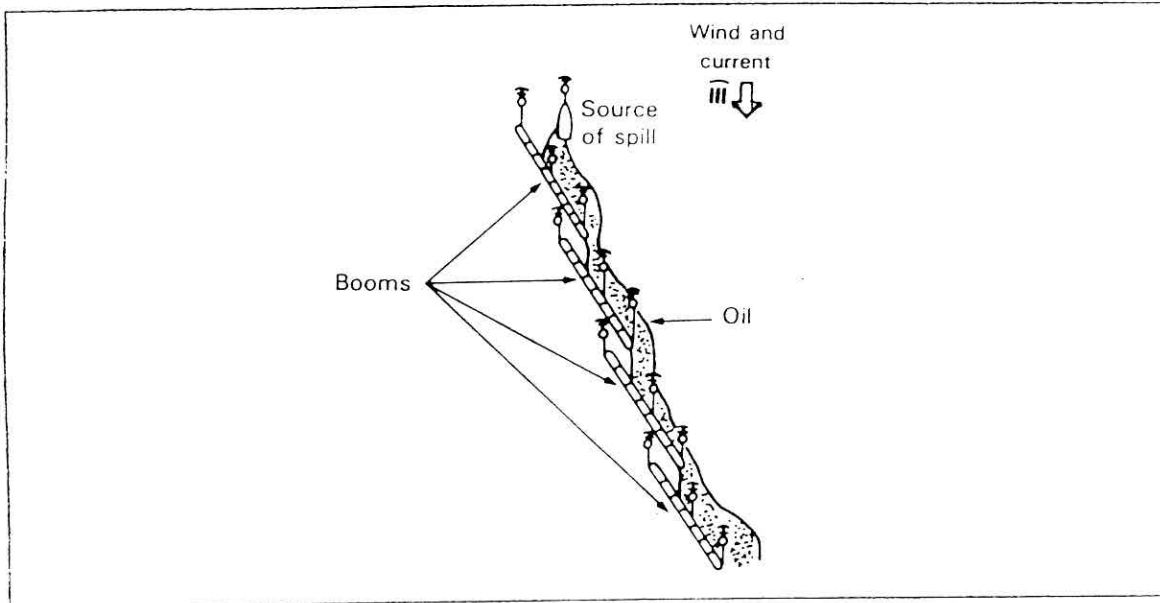

Figure 13 - Deflection deployment

5.5 Towing Booms

If wind and current velocity are too high for stationary containment or if the oil is already widely scattered, booms can be towed at low speed through the water. The method is primarily used in open sea. For effective recovery of oil spreading over a wide area, a system which is a combination of boom and skimmer can be used.

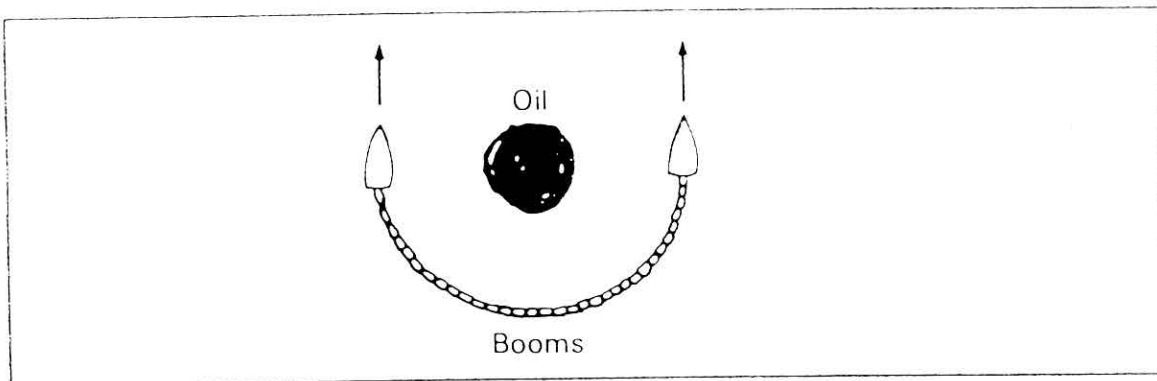

Figure 14 - "U" shaped towing

5.6 Free-drift Containment

If the current velocity is too high or the water is too deep for effective mooring of booms, it may be possible to allow the oil encircled by the booms to drift freely whilst recovery is undertaken. The rate of drift may be reduced by use of sea anchors or drogues. In shallower waters lengths of chain or other material may be used for the same purpose.

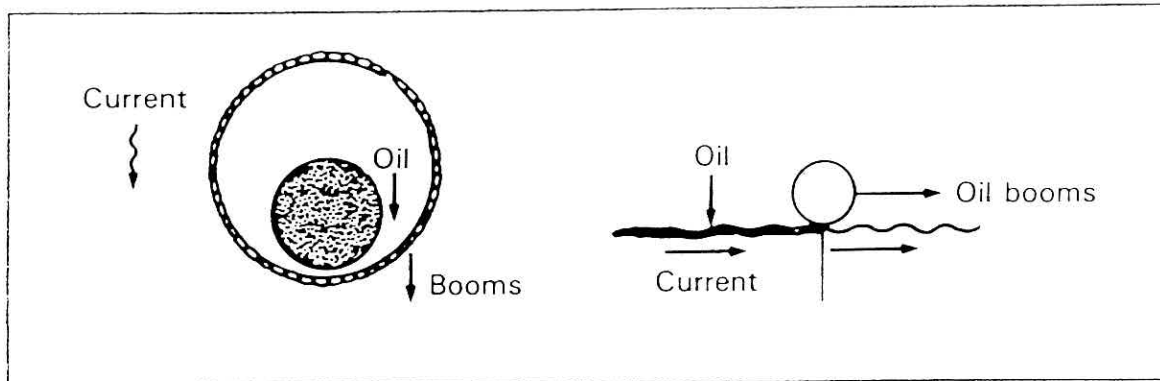

Figure 15 - Free drift containment

5.7 Multiple Setting

Oil may escape from the boom because of the phenomenon of entrainment describe earlier and double or triple setting of booms may be necessary.

If multiple deployment is necessary, some separation must be maintained between booms. At a current velocities high enough to tilt the skirt or cause entrainment, a separation of 1-5 metres between the booms is effective for the escaping oil to be held by secondary barriers.

6.0 Boom Deployment

Deployment of booms involves hard and, sometimes, dangerous work and must be properly supervised. The following points should be taken into consideration:

6.1 Deployment Plan

A sound deployment plan must be drawn up, taking into consideration type of oil spilled, source of spill, quantity involved, extent of spread, environmental sensitivity, etc. In preparing such a plan, the site of deployment of booms, the kind and length of boom available, the method of deployment to be used and the availability and readiness of work boats must be taken into account. In particular the length of the boom required is often underestimated, especially when angling to counter the effects of currents.

6.2 Precaution When Handling Boom

The outer covers of commercially available booms are made mostly rubberised or plasticised fabrics which are susceptible to rips and tears when dragged on rough surfaces such as warehouse floors and jetties. The utmost care must be taken not to damage the boom in the course of handling and transportation. When damaged, booms may have reduced effectiveness in retention of oil. Inflatable booms can lose buoyancy when damaged. The force of wind and waves during rough weather may damage booms or connectors, or cause mooring drag.

6.3 Precautions for Deployment

Care must be taken when preparing booms for deployment to avoid twisting and kinking since it is difficult to correct this from the deck of a vessel or once the boom is in the water. Rough seas and strong winds cause major stresses on booms and their moorings which may result in boom failure.

6.4 Maintenance of Configuration

The configuration of booms deployed at sea may be difficult to maintain because of waves and wind, and their effectiveness in retaining oil may be reduced.

To maintain the chosen configuration in adverse weather, the following measures must be taken:

- if booms are moored by anchors, increase the number of anchors and shorten the distance between the anchoring points.
- if booms are encircling a vessel spilling oil, place convenient spacing items such as floating pontoon between the ship's hull and the boom to stop the boom abrading against the hull.

6.5 Mooring of Boom

Booms may be moored by conventional anchors or concrete blocks or to a wharf or ship's hull by special attachments at the end.

6.5.1 Mooring by Anchors or Concrete Blocks

Anchors and concrete blocks are most commonly used in mooring booms. The number of anchoring points required depends on the configuration intended and wind and current strength.

Usually, mooring ropes of five times the depth of water are required, and when ropes of buoyant material are used, this must be compensated for by adding extra chain or weights to the ropes. It is important to avoid vertical tension on the boom. This can be done by installing a buoy on the mooring line 3-4 metres from the boom.

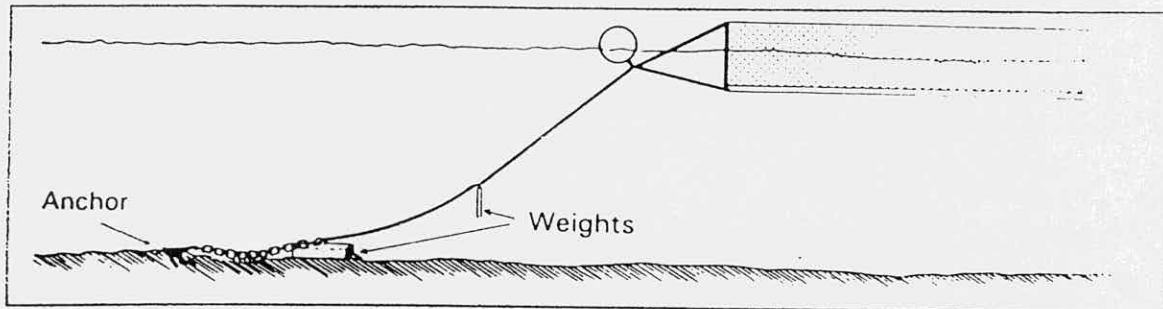

Figure 16 - Typical mooring arrangement

6.5.2 Use of Special End Attachments

Special devices are available to ensure oil-tight connection of one end of the boom to a wharf or ship's hull:

I-beam materials: This device uses a piece of I-beam driven vertically into the sea bed or fixed on a jetty face as a terminal. A sliding floater, to which booms are connected, is fitted on the beam. The floater can slide to accommodate tidal changes.

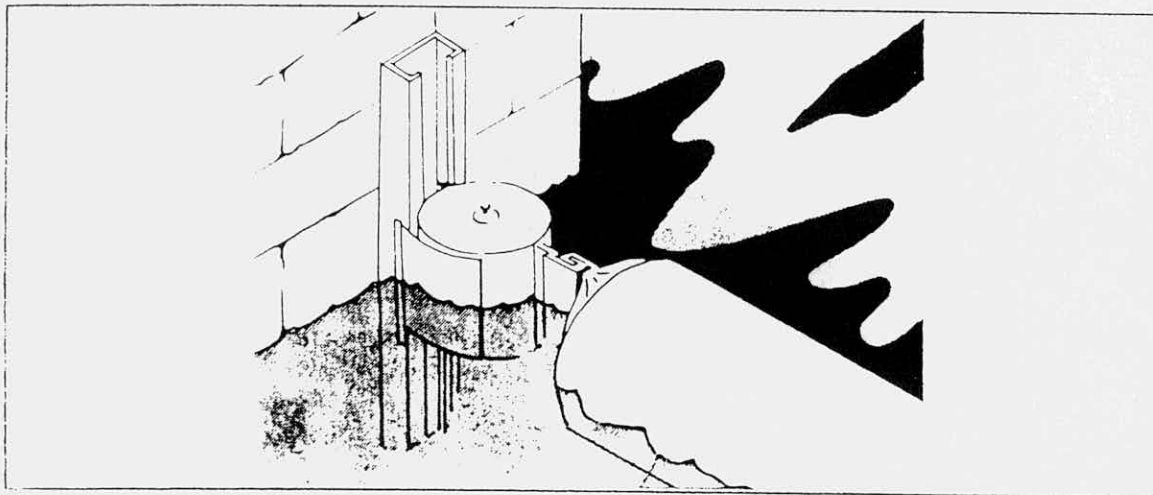

Figure 17 - Boom connection consisting of a floatation cylinder with a sliding shoe fitting into a vertical runner fixed to a harbour wall

Magnetic connectors: One end of the boom is attached to a magnetic connector which holds fast to a steel surface such as ship's hull or jetty piling. These may have to be manually adjusted to compensate for change in ship's draft or tidal level.

Weighted guy line: A length of weighted guy line is thrown over the booms and the booms are pulled close to the sea wall. The line can be secured to a bollard.

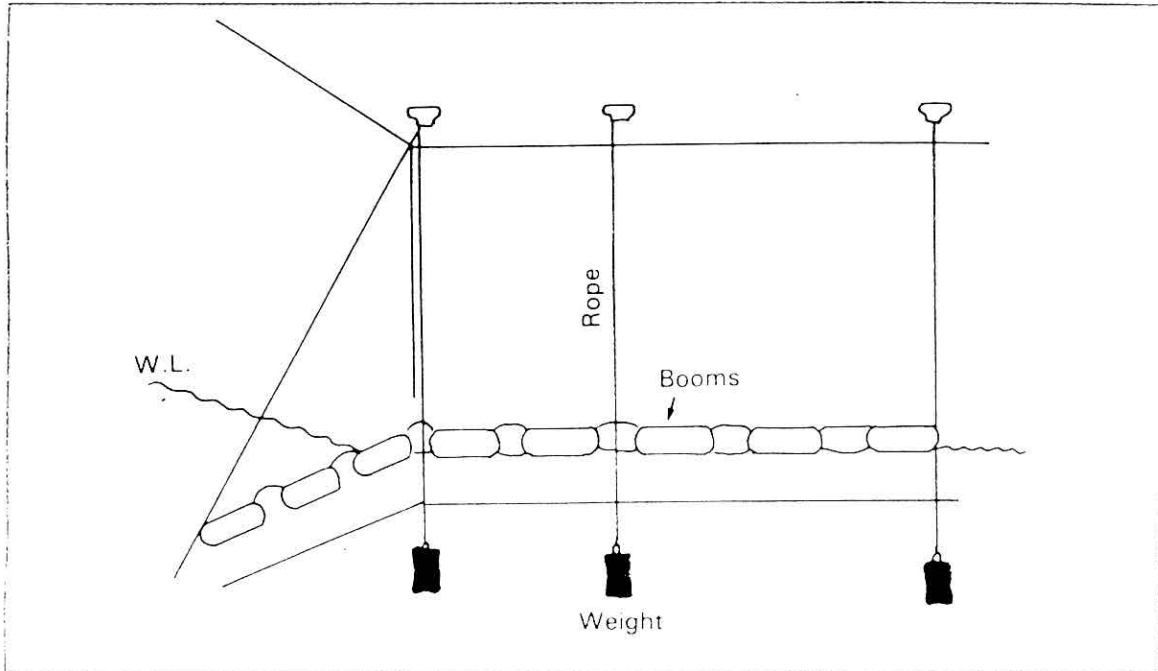

Figure 18 - Weighted guy lines

MECHANICAL RECOVERY SYSTEMS

1.0 Type of Skimmer

Skimmer is a device designed to recover oil off the sea surface. It varies greatly in size and operating principles. In general, skimmer can be classified in four basic categories:

- suction devices;
- devices using oleophilic materials;
- induction devices; and
- devices using other principles.

1.1 Suction Skimmer

Suction skimmer consists of an inlet head, a pump and operate by drawing oil into a storage tank through a restricted opening designed to limit the quantity of water which accompanies the oil.

Ideally the inlet head should be positioned so that oil can enter but water is excluded. In practice this is not possible as the oil layer will vary in thickness and wave motion can swamp the head. To minimise the effects of waves, the inlet head should float at the oil/water interface with the minimum possible inertia. The size of the opening and capacity will determine recovery rate. A number of specially designed heads are commercially available, such as the surface suction and adjustable weir skimmer.

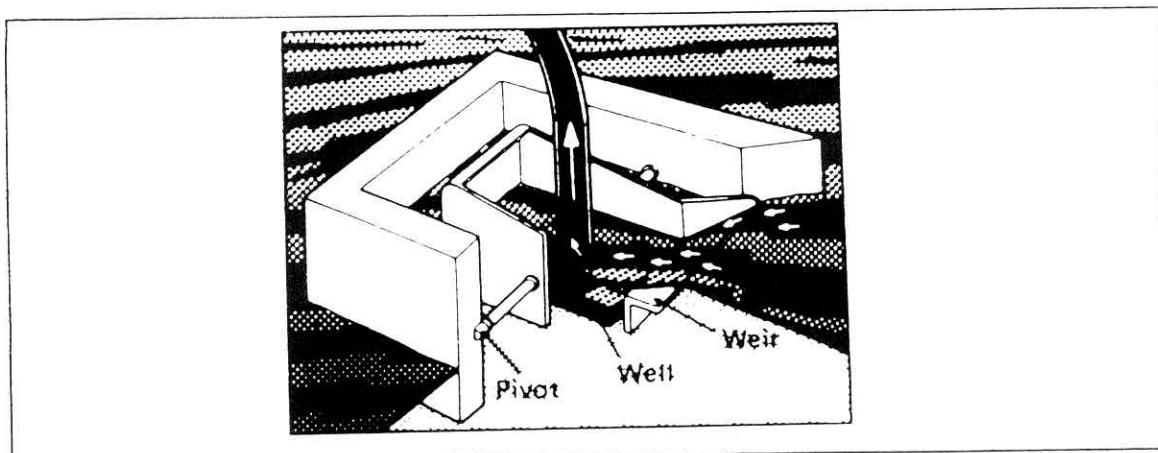

Figure 19 - Weir skimmer

Relatively slow moving positive displacement pumps are preferable to high-speed centrifugal pumps for pumping oily water mixtures to avoid churning these mixtures into fine droplets of emulsions, which can interfere with the separation of the collected mixture. Alternatively, a vacuum or eductor system may be used to draw the oily water mixture into the storage tank.

1.2 Oleophilic Skimmer

These devices, use an oleophilic materials in the form of a disc, drum, belt or rope to which the oil adheres and are described in the following paragraphs.

1.2.1 Disc System

Discs are arranged vertically on a horizontal drive shaft which may be either linear or arranged in a circle. The lower half of each disc dips into the oil and as the disc rotates the oil adheres to its surface and is picked up from the water surface. The oil is then wiped off into collection channels and drains into reservoir.

Disc skimmers are more effective in calm water and will not work with very viscous oil. However, some incorporate intermeshing toothed discs to alleviate the later problem. They can be obtained in a wide variety of sizes. They generally require a power unit (usually a separate hydraulic power pack) to rotate the discs and pump the recovered oil from the reservoir to storage.

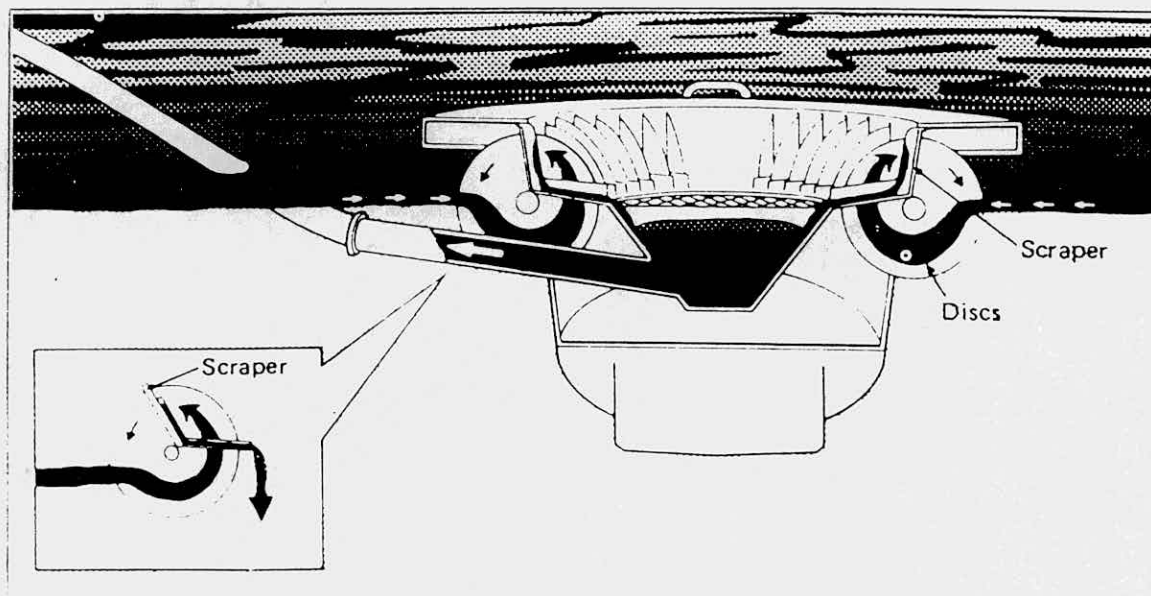

Figure 20 - Disc skimmers

1.2.2 Drum System

This system uses a large diameter rotating cylinder on a horizontal axis. The drum or cylinder is partially immersed and oil which adheres to the surface is removed by a scraper and drained into reservoir.

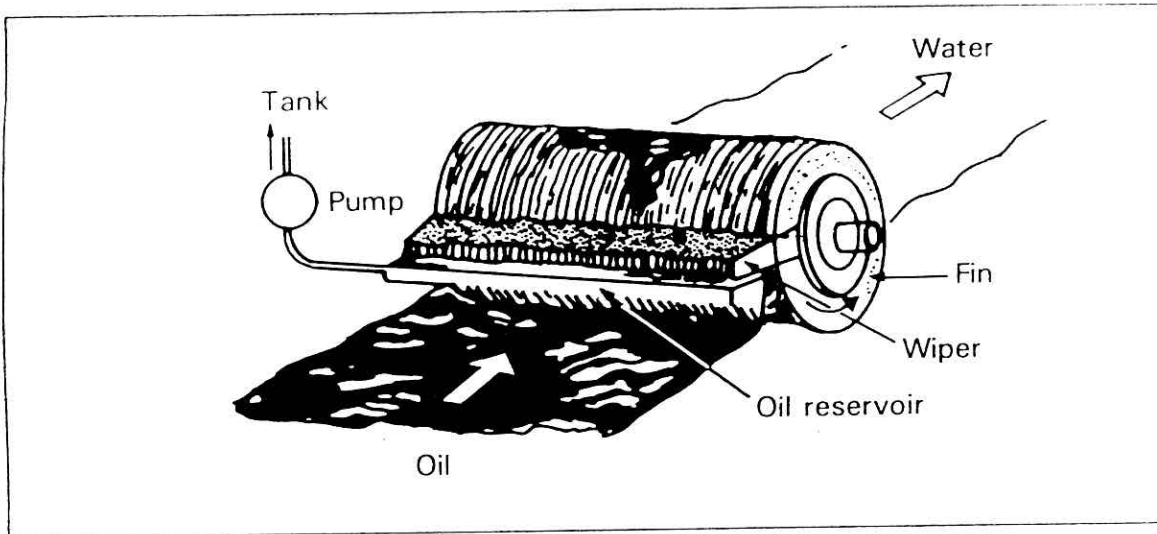

Figure 21 - Drum fin

1.2.3 Belt System

The system uses oleophilic material or a belt which runs continuously through the oil layer picking up the oil. The belt runs between two end rollers where the oil adhering to it is scraped off into a reservoir. A pump transfers oil from the reservoir to a holding tank on shore or on a vessel.

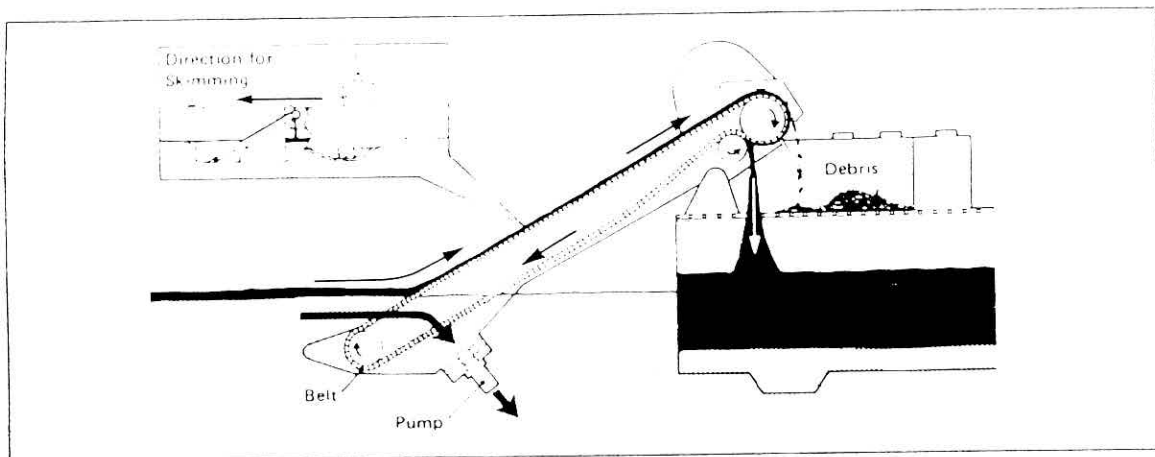

Figure 21 - Belt skimmers

1.2.4 Endless adhesion rope systems

A loop or loops of rope made of synthetic oleophilic material runs continuously across the water surface between a collection device, which drives the ropes, and pulleys held by moorings. The ropes adsorb oil and carry it into the collection device where rollers squeeze the oil out of the ropes into a reservoir. The length of the ropes can be adjusted to suit the area to be cleaned.

The collection device can be mounted on the shore or on a vessel. Alternatively, it may be designed to be suspended above the sea from a crane or derrick with multiple rope loops hanging vertically between the collection device and the water surface.

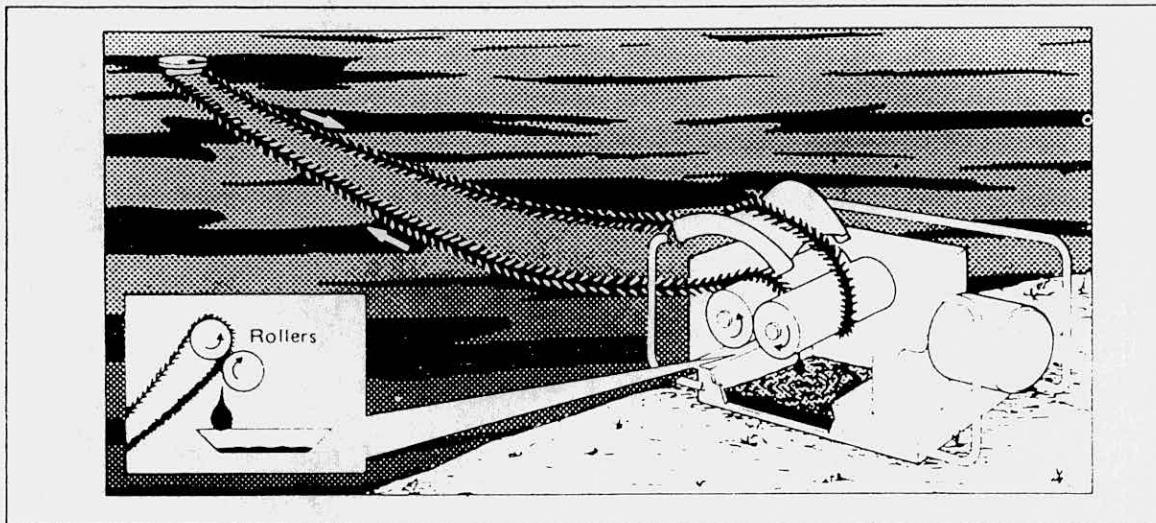

Figure 22 - Oleophilic rope skimmers

1.3 Induction Systems

Induction systems are usually built into vessels, either with or without means of propulsion. The vessel moves into the oil slick so that the oil flows into an onboard storage area where the effects of waves and current are reduced and separated oil may be removed by conventional means.

A variety of induction systems are available, using different combinations of collection and separation techniques.

As with other systems, efficiency is reduced by clogging with seaweed and other debris, unless protective screens are fitted.

Commercially available induction-type devices include :

1.3.1 Multiple Weir System

The oil/water mixture is induced to flow through a tank containing a series of weirs at a fixed depth below the water surface. Turbulence is avoided by controlling the inflow. Oil floats to the surface of the tank and overflows into a reservoir.

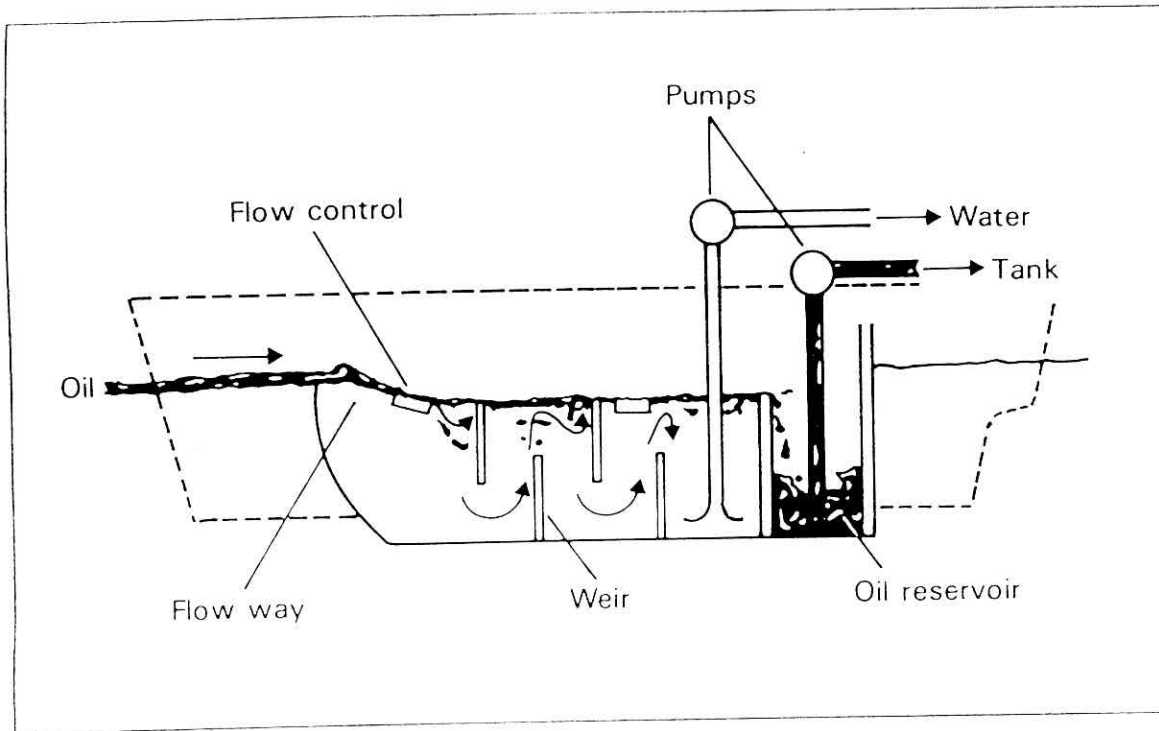

Figure 23 - Multiple weir system

1.3.2 Inclined Plane System

The inclined plane consists of a belt which, in some cases, rotates in the opposite direction to the forward motion of the vessel to reduce the relative velocity between the belt and the water.

As the vessel advances through the water, surface oil layers are forced down the inclined plane at the end of which the oil is released into a reservoir and the oil-free water escapes.

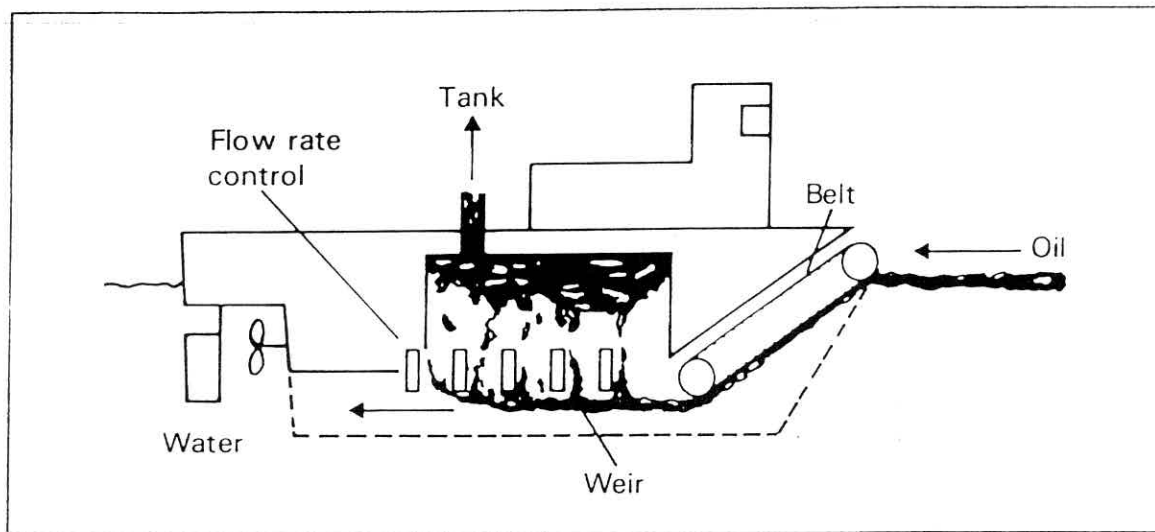

Figure 24 - Dynamic inclined plane skimmer

1.3.3 Hydrocyclone System

A hydrocyclone system utilises the concept of centrifugal forces. As the craft moves through the water, oil and water layers are forced to flow tangentially into a chamber where they rotate at high speed. Centrifugal forces separate the oil from the water. The oil moves nearer to the centre of the vortex where it is collected by the pumping system. The water escapes through the opening at the bottom of the chamber. The stability of the vortex is somewhat affected by waves.

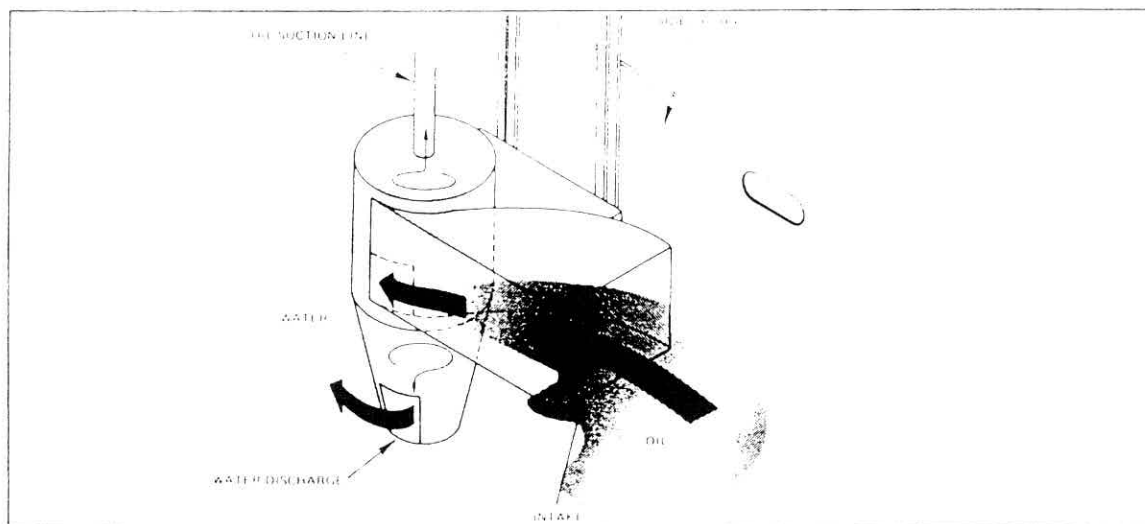

Figure 25 - Hydrocyclone

1.4 Other Recovery System

1.4.1 Screw Pump

These systems are principally designed to recover viscous oils and are based on the principle of the Archimedes screw. They are quite tolerant of debris.

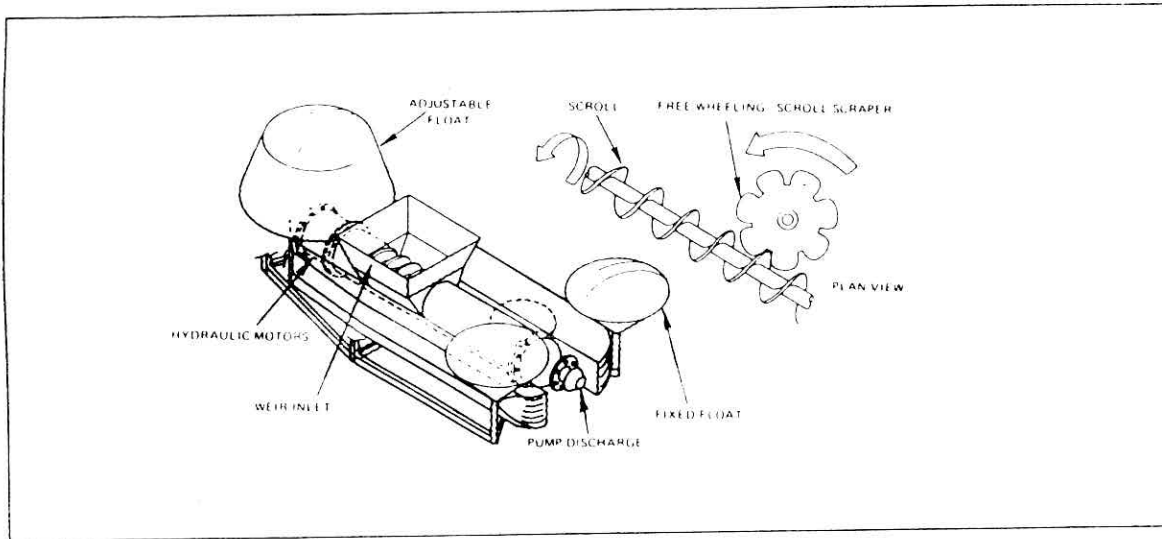

Figure 26 - Screw pump

1.4.2 Vortex Skimmer

These systems use a paddled induced vortex to draw the oil and water over a weir into a separation chamber from which separated oil is removed and water drained away.

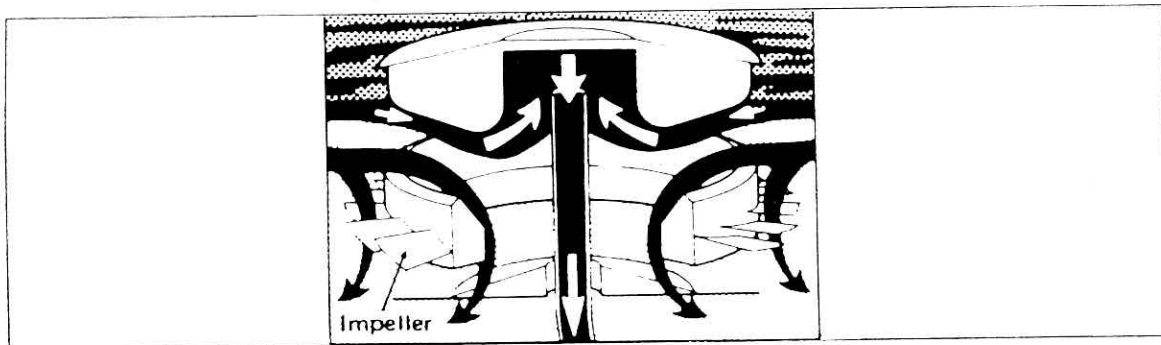

Figure 27 - Vortex skimmers

There many other alternatives in collecting spilt oil such as nets, using vacuum trucks, mechanical grabs or manual recovery adapted to environmental suitability and availability of equipment.

2.0 Performance and Limitation

There is no skimmer that has been proven capable of performing 100 percent efficiency. Performance of an oil skimmer is usually measured by the oil/water ratio. For a skimmer which use suction system, performance is dictated by the relation between the size of the opening and the wave length and the efficiency depends on oil viscosity, thickness of the oil and sea state. Clogging by marine vegetation and small debris will also reduce the efficiency. Another problem is usually relatively short length of the suction hoses, which restrict its operating area.

Oleophilic devices are more effective in calm water and will not work with viscous oil. Though endless adhesion rope system is very flexible in operation, but it causes mess especially when operating onboard a vessel.

3.0 Sweeping with Booms

Spilled oil can be contained by booms and recovered by skimmers or by independently operating oil recovery vessels. For effective recovery of oil spreading over a wide area, a system which is a combination of spill control equipment such as skimmer, boom, etc. and oil recovery vessels can be used.

It is possible to use vessels of opportunity equipped with oil recovery equipment as the component of these systems.

Various systems have been developed in many countries and these can be classified into the following three types according to the number of vessels used for the operation.

3.1 Single Vessels System

This system consist of single vessel equipped with special booms extended from one or both sides of the vessel by means of a rigid arms or bridles. Oil is collected in a pocket in the boom or diverted in a watertight compartment in the hull of the vessel. The oil is then recovered by a skimmer or brushes and pumped into the vessel's storage tanks.

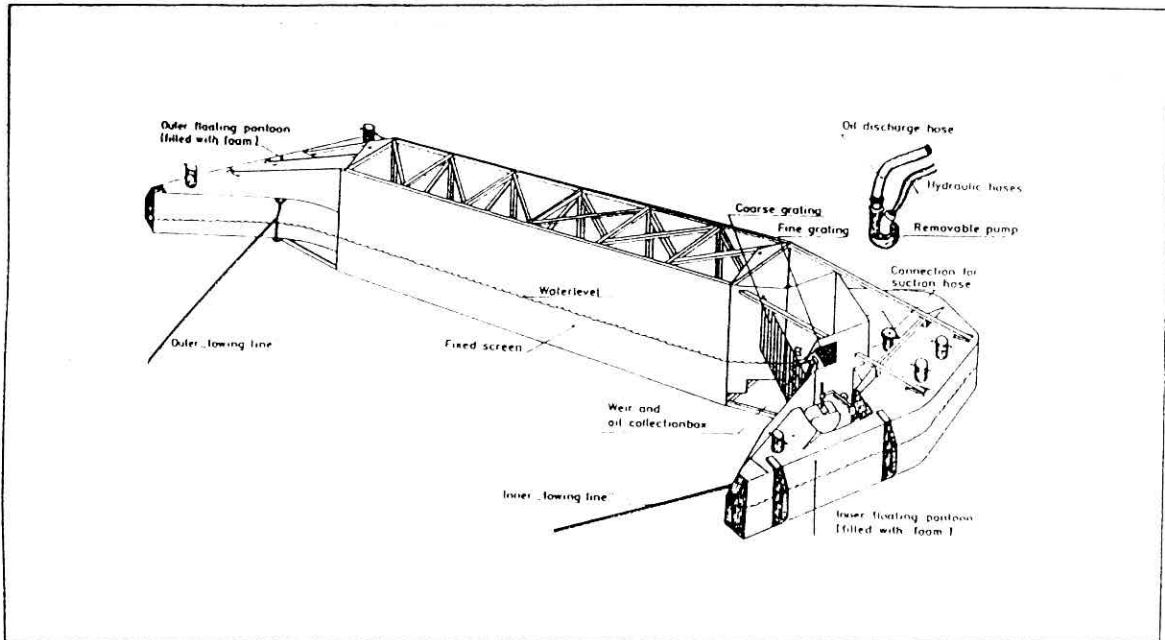

Figure 28 - Sweeping arm (Marflex)

3.2 Two Vessels Sweep System

This system consists of two vessels, a special oil boom and skimmer. The boom is towed in "J" configuration by two vessels, one at each end, and collected oil is recovered by an oil skimmer at the apex of the boom. Recovered oil-water mixture is pumped into the tank of one of the vessels for storage.

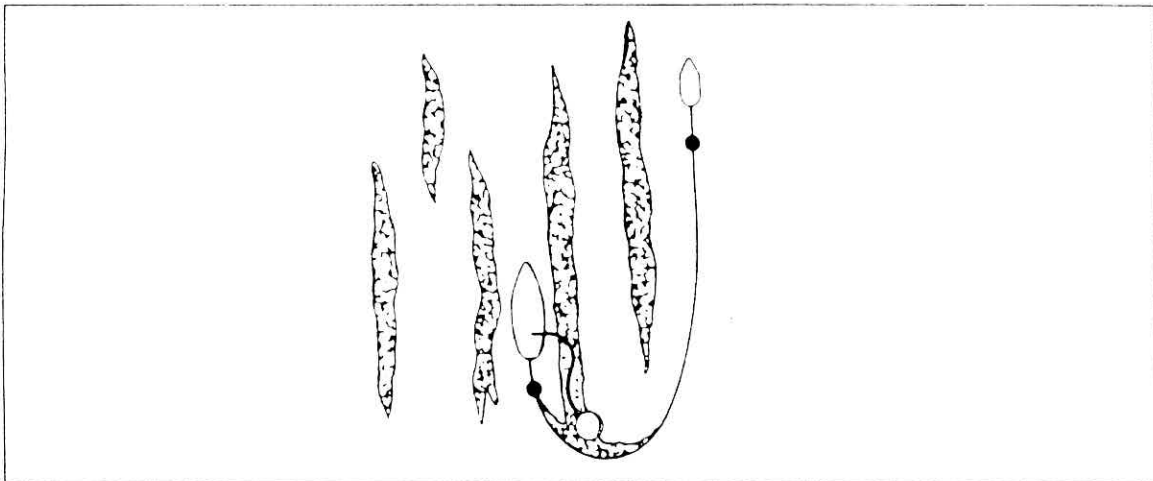

Figure 29 - "J" configuration towed by two vessels, one of which deploys the recovery device

3.3 Three Vessels Sweep System

This system consist of three vessels, an oil boom and skimmer, and can be deployed in one of the following ways:

- The boom is towed in "V" configuration by two vessels. Collected oil is recovered by the skimmer placed at the apex of the "V" in the boom and pumped into the third vessel.
- Two vessels tow the boom in a "U" configuration. Oil-water mixture collected at the apex of the oil boom is drawn through integral manifolds and pumped to a storage barge.
- Two vessels tow to oil boom in a "U" configuration. Oil concentrated by the boom is allowed to leak at the apex. The concentrated oil can then be recovered by using the method described for single vessel sweep system.

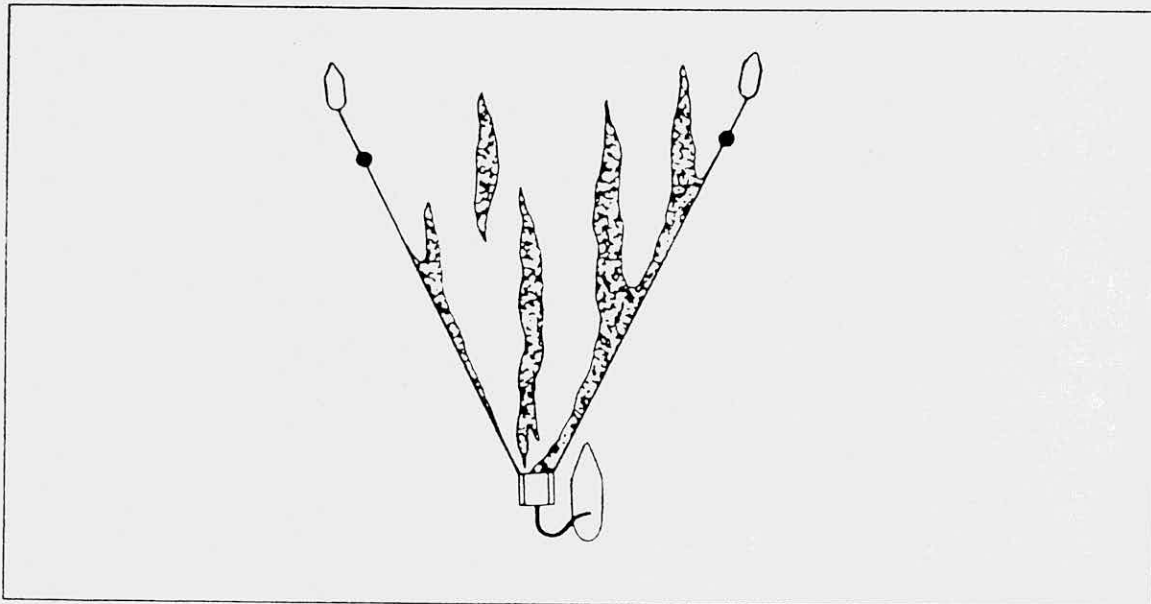

Figure 30 - "V" configuration towed by two vessels - collection device towed with boom array and oil transferred to third vessel

4.0 Precautions for the operation of sweep systems

- The wave height, wind direction and relative current speed which limit the performance of the system should be fully understood otherwise recovery efforts may be unsuccessful.

- To achieve the optimum performance, thorough training in vessel control and system operation is necessary. In particular, a high level seamanship is required for manoeuvring multiple vessels in combination with booms at slow speed.
- The vessel or vessels to be used for the sweep system should be pre-designated and the equipment should be stored in the vicinity of the berth for immediate use in case of an accident. On the pier, there should also be lifting machinery for hauling and rigging of skimmers and booms and other control equipment on to the vessel.
- Where recovery of oil-water mixture is expected to exceed the capacity of the storage tanks of the vessel, sufficient tank capacity to transfer oil-water mixture from recovering vessel and to transport it to the shore facility should be arranged.
- Flotsam and jetsam hamper oil recovery operations. In such an event, it may be necessary to deploy supporting vessels to remove debris obstructive to the operation.

THE USE OF CHEMICAL DISPERSANT

1.0 Mechanism of Chemical Dispersant

Wave action and turbulence due to tides and current will cause some of the oil to break up into small droplets which can be carried down into water column. This process, which is known as dispersion, can be enhanced by the application of dispersant.

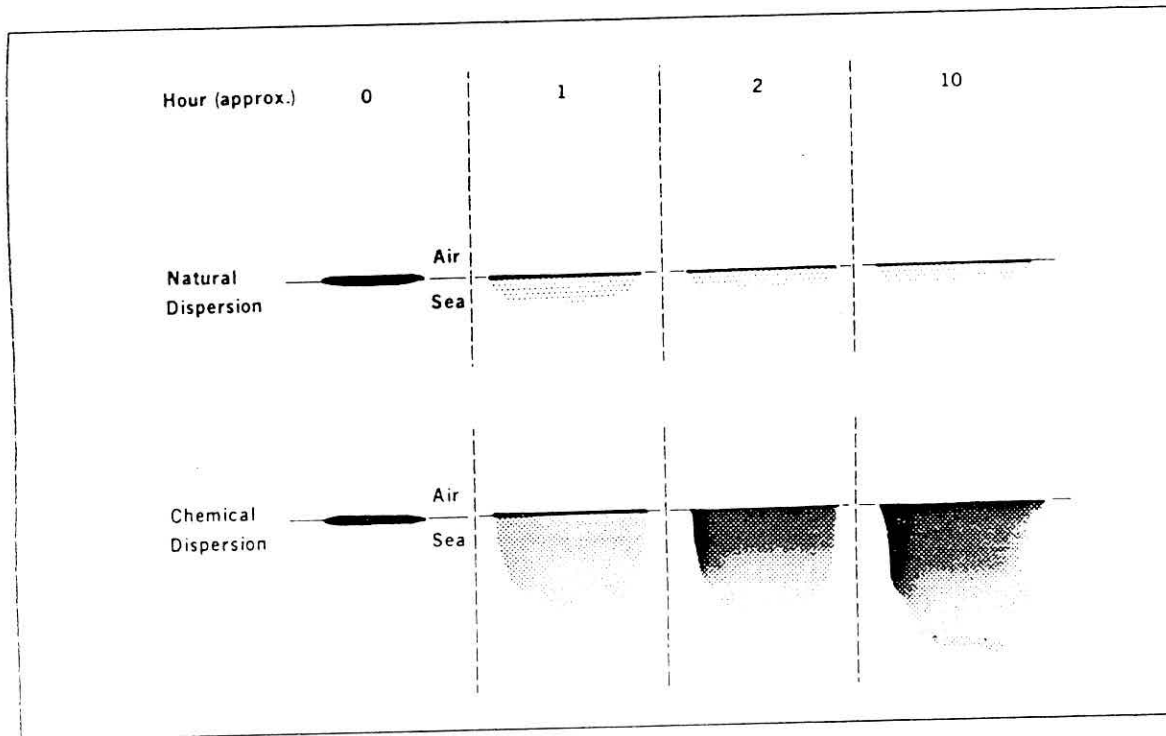

Figure 31 - Natural versus chemical dispersant

Dispersants are chemical agents which alter the physical behavior of oil on the sea surface. They consist of a mixture of surface active agents dissolved in a solvent which assists penetration of the mixture into the oil. The surface active agents reduce the surface tension of the oil, so increasing the rate of droplet formation and inhibiting coalescence of the droplets. Dispersed oil will degrade much more rapidly than oil in a surface slick and in some circumstances it will present less of a threat to the environment.

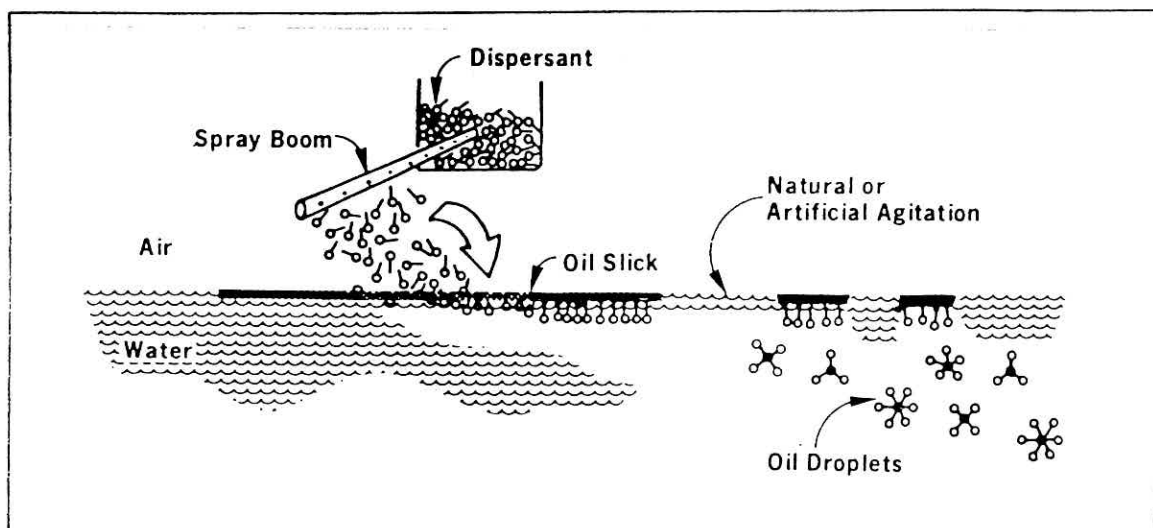

Figure 32 - Simplified behaviour of surface-active agent

The environmental gains resulting from an increase in the rate of biodegradation may be offset by the toxicity of the dispersants themselves, and the dispersed oil made available to organisms in the water body. When dispersants were first used, it stirred considerable controversy as to the acceptability of dispersants in combating oil pollution. As a result of a continuous experiment and research, dispersant which are more effective and less toxic are now being manufactured.

In Malaysia, the policy is to employ mechanical recovery method to combat oil pollution as much as possible and dispersants are viable option with an approval of the Department of the Environment.

2.0 Dispersants Effectiveness

Dispersants will not work effectively under certain circumstances. Heavy fuel oils and heavier crudes will not disperse, because of their high viscosity. It has been generally accepted that oil with a viscosity of higher than 2,000 mPas is difficult to disperse and that for oils whose viscosities exceed 5,000 mPas, dispersants are likely to be ineffective. Lubricating oils are also difficult to disperse because of the additives they contain.

Dispersant will not usually effective on oils which have weathered to a state which their viscosity is substantially greater than 2,000 mPas. The limiting effect is emulsification, and many dispersible oil on initial contact with the sea lose their dispersability within few hours. Therefore, for these oil it is important to apply the dispersant as soon as possible after the spill.

Light fuel oils such as diesel disperse naturally so rapidly that there is little to be gained by the use of dispersant, except possibly to reduce a potential fire hazard.

Since dispersants work by enhancing the rate of natural dispersion, some turbulence is necessary for the dispersant to be effective. Beaufort wind force three (3) or higher is normally required to give adequate natural mixing energy. Mechanical turbulence can be effective-mixing devices can be towed through the water, or ship's propellers can be used to churn up the slick. On beaches, tidal energy, surf or salt-water spray can provide the necessary mixing.

3.0 Type of Dispersant

Dispersant are available in two (2) types :

3.1 Conventional

Conventional dispersants are solvent based. They consist of an aqueous or hydrocarbon solvent contain a mixture of emulsifiers and are applied undiluted.

3.2 Concentrate

Concentrated dispersants are a mixture containing emulsifiers, solvents and wetting agents, containing more active ingredients than conventional a dispersing a higher volume of oil per activated volume of dispersant. They are applied undiluted for aerial application and diluted when applied by surface crafts.

4.0 Methods of Application

In considering proper system of application, three (3) major concern arise, namely time cost and operational environment. It is important that application of dispersant is acted before weathering occurs and before oil spill reaches sensitive environment.

Application of dispersants is costly, then it must be weighed against other response alternatives and operational environment includes physical factors such as wind, sea state and surrounding topography has to be considered.

4.1 Spraying from ship

Application of dispersant can be performed by almost any ships. They can carry large loads as well as versatile but very much slower than aircraft. This means that for a fast response, potentially available vessel should be identified. Shipborne spraying equipment can either be of a permanent mounted type or a portable inshore spray sets for use by small vessels. Generally, spray booms are mounted as far forward as possible to prevent the tendency of the bow wave moving oil aside. Spray nozzles should match pump rates to give a uniform spray

and mixing energy must be provided and this can be supplied by the bow wave of the vessels, ship's propellers or by mechanical devices towed by the ship.

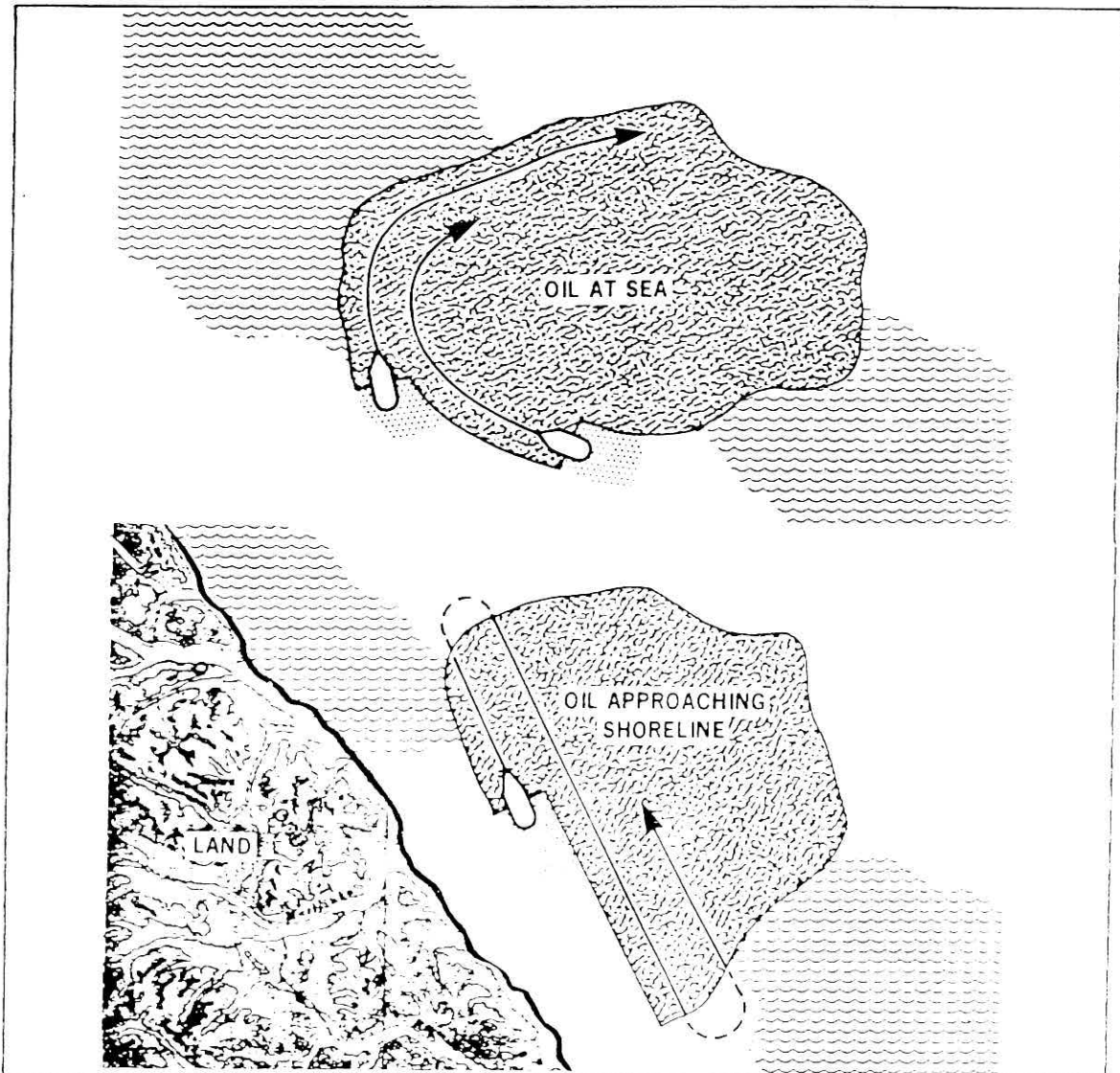

Figure 33 - Surface application

4.2 Spraying by Aircraft

Application of dispersant by aircraft could be a useful solution particularly when dealing with large oil spill as it provides a very rapid response methods to reduce effect of weathering to spilt oil, thus increase dispersion rate. Since mechanical mixing is not possible when spraying from aircraft, it is necessary to rely on appropriate area condition for adequate natural mixing.

Helicopters are much more maneuverable than fixed wing aircraft and so are preferable for use in confined areas but the main disadvantage is their relatively low carrying capacity.

Effectiveness of aerial spraying rely very much on the size of droplets. Ideally, droplets should be between about 300 to 1,000 microns in diameter. At this size they are too large to form mists which are susceptible to wind drift, but are not so large that they pass through the oil to be lost in the sea below.

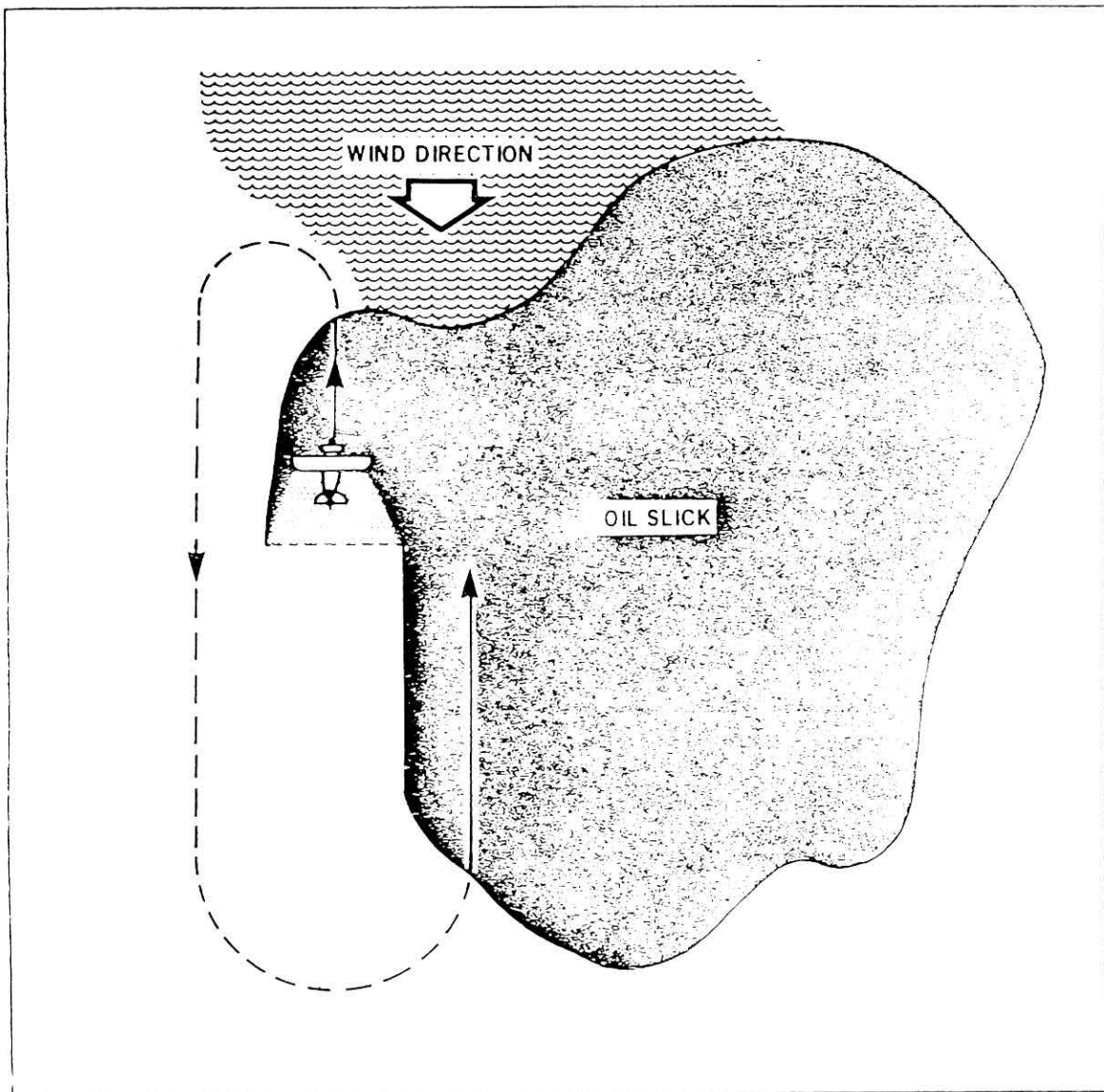

Figure 34 - Aerial application

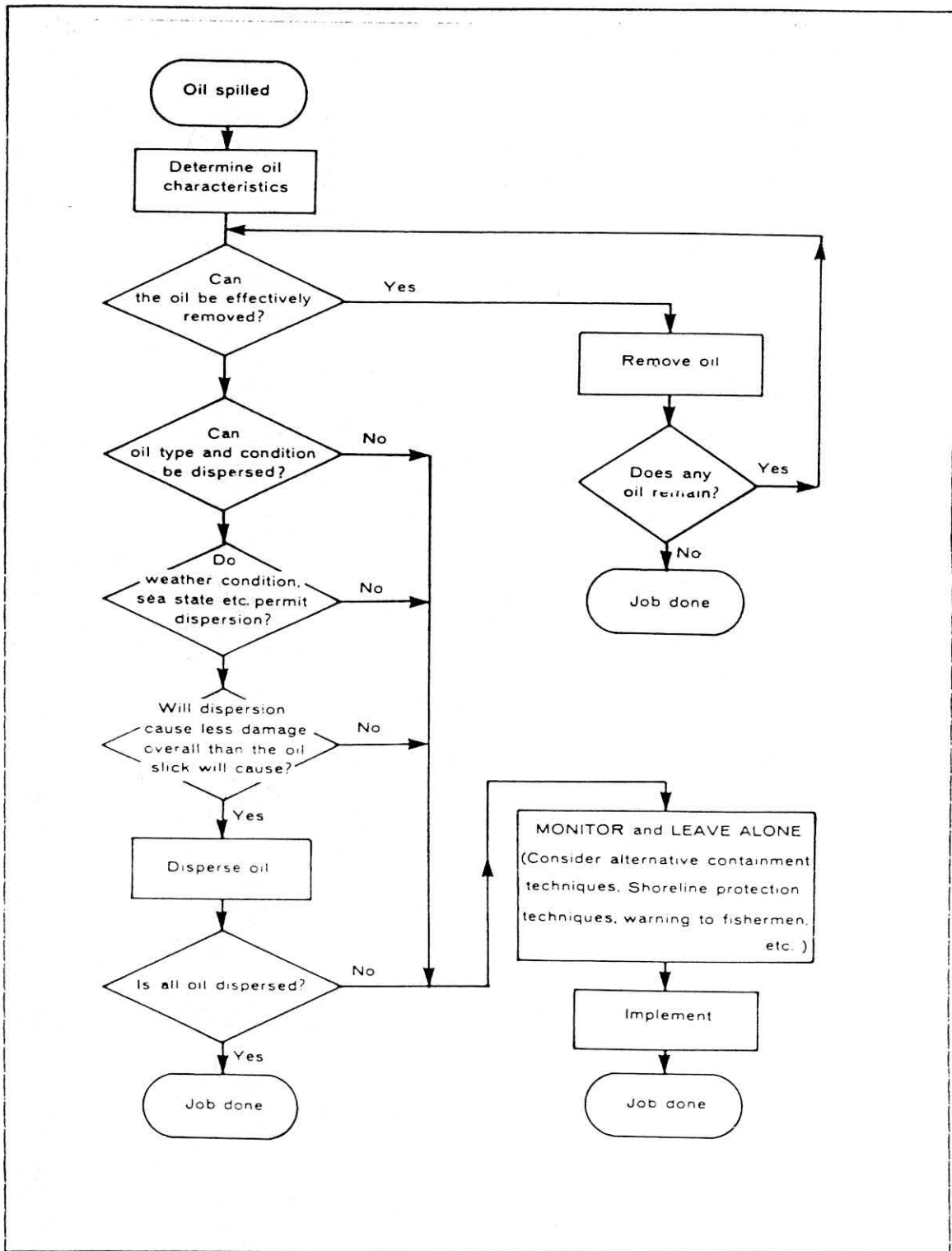

Figure 36 - An example of a typical oil spill response decision procedure (with particular reference to oil spill dispersants)

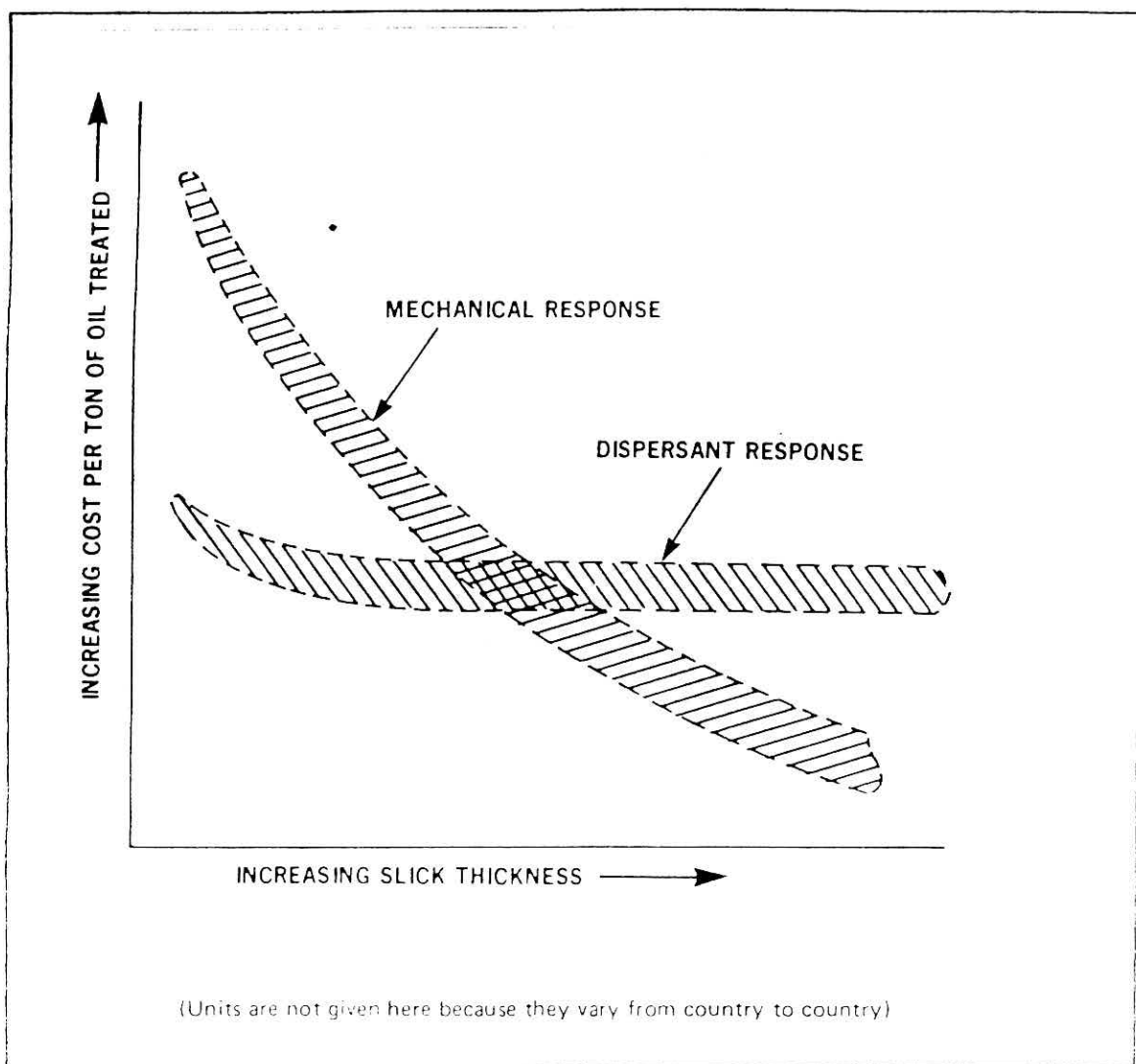

Figure 35 - Qualitative description of costs for mechanical and dispersant response to spill (assuming both types of equipment are available)

IKLAS Bahan Kursus

Tajuk Kursus : Kursus Kawalan Tumpahan Minyak
Dan Pembersihan Pantai Negeri Pulau Pinang

**KURSUS KESEDARAN KAWALAN
TUMPAHAN MINYAK DAN
PEMBERSIHAN PANTAI
NEGERI PULAU PINANG**

TAJUK:
Fate of oil Spills

Oleh:
Encik Radzuan Yusof

FATE OF OIL SPILLS

1.0 Properties of Oil

Oils are generally classified either as crude oils and refined products or according to their viscosity. The varying composition of crude oils and refined products is shown not only by the different specifications, but also by their different behavior in and on water and by different oil-environment interactions.

When an oil spill occurs at sea oil will float and begin to spread, with the exception of a few oils whose density exceeds that of water and which therefore sink. Individual oil properties are very important since they influence both its behavior on the sea surface and its rate of dissipation by natural processes.

Oils may pose hazards to human health, in particular from prolonged skin contact and inhalation of vapours. Some crude oils contain hydrogen sulphide gas which is highly toxic. Good personal hygiene and proper safety precautions should be exercised by all response personnel coming into contact with oils.

1.1 Density (Specific Gravity)

This dictates the buoyancy of an oil on water and it influences spreading and natural dispersion. The density of crude oils and petroleum products is usually expressed in term of API gravity in accordance with the following formula :

$$\text{API} = \frac{141.5}{\text{specific gravity}} - 131.5$$

As a general rule, oils with a low density (high API gravity) tend to have low viscosities and contain a high proportion of volatile components.

1.2 Boiling Point and Boiling Range

The rate at which oils evaporate is linked to their initial boiling point and boiling range. The lower these are, the faster evaporation will occur.

1.3 Viscosity

The viscosity of an oil is its resistance to flow. High viscosity oils flow with difficulty whilst those with low viscosity are highly mobile. Viscosities decrease with increasing temperature and so seawater temperature and absorption of heat from the sun are important considerations.

1.4 Pour Point

The pour point of an oil is the temperature below which the oil becomes a semi-solid and will not flow. This effect is the result of the formation of an internal micro-crystalline structure. The pour point of crude oils generally varies from -35°C to +40°C.

1.5 Flashpoint

The flashpoint is the lowest temperature at which sufficient vapour exists above the spilled oil to yield a flammable mixture. This is an important factor in relation to the safety of clean-up operations. Many freshly spilled oils may be easily ignited until the more volatile components have evaporated and dispersed in the atmosphere.

1.6 Solubility

Some components of oils are soluble in water. Generally the more volatile components are also the more soluble. Although solubility is small relative to evaporation, it can be significant for toxicity to marine life.

1.7 Asphaltene Content

Asphaltenes play a major role in the formation and stability of water-in-oil emulsions. Low asphaltene oils generally do not form stable emulsions.

2.0 Weathering Processes

Oil spilled on the sea undergoes a series of processes known as weathering which will change its characteristics of behavior. The main factors affecting the behavior of oil are:

- physical characteristics of the oil, in particular, specific gravity, viscosity and volatility;
- composition and chemical characteristics of the oil;
- meteorological conditions (sea state, sunlight and air temperatures), and
- characteristics of the seawater (specific gravity, currents, temperature, presence of bacteria, nutrients and dissolved oxygen and suspended solids).

A knowledge of these processes and how they interact to alter the nature of oil is valuable when responding to spills

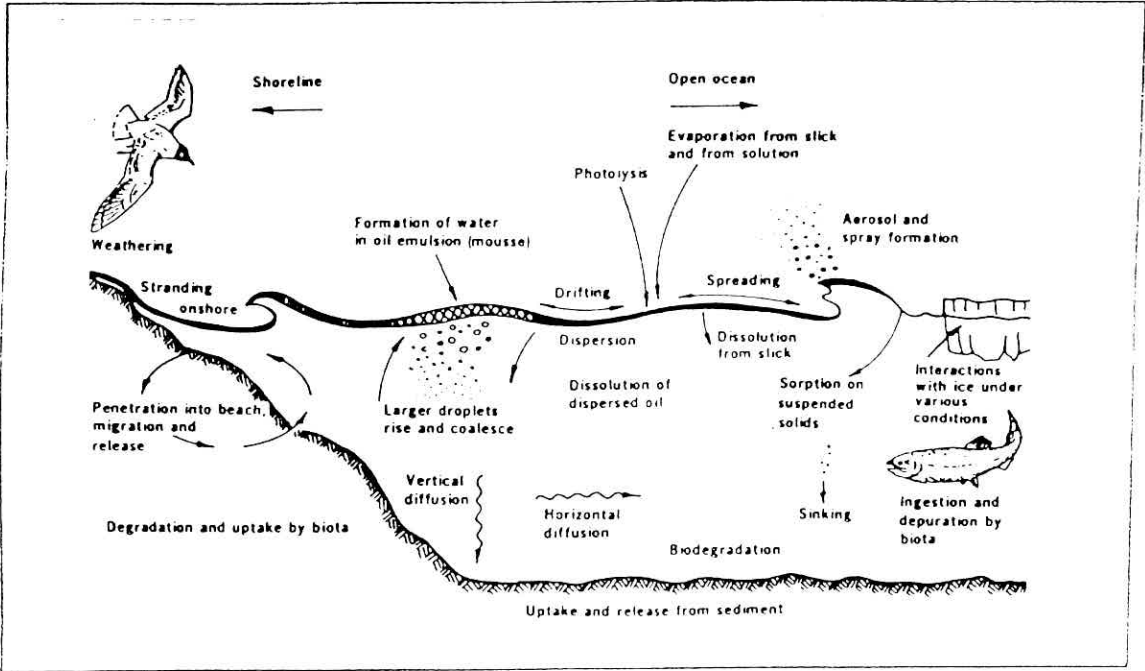

Figure 1 - Processes taking place after an oil spill

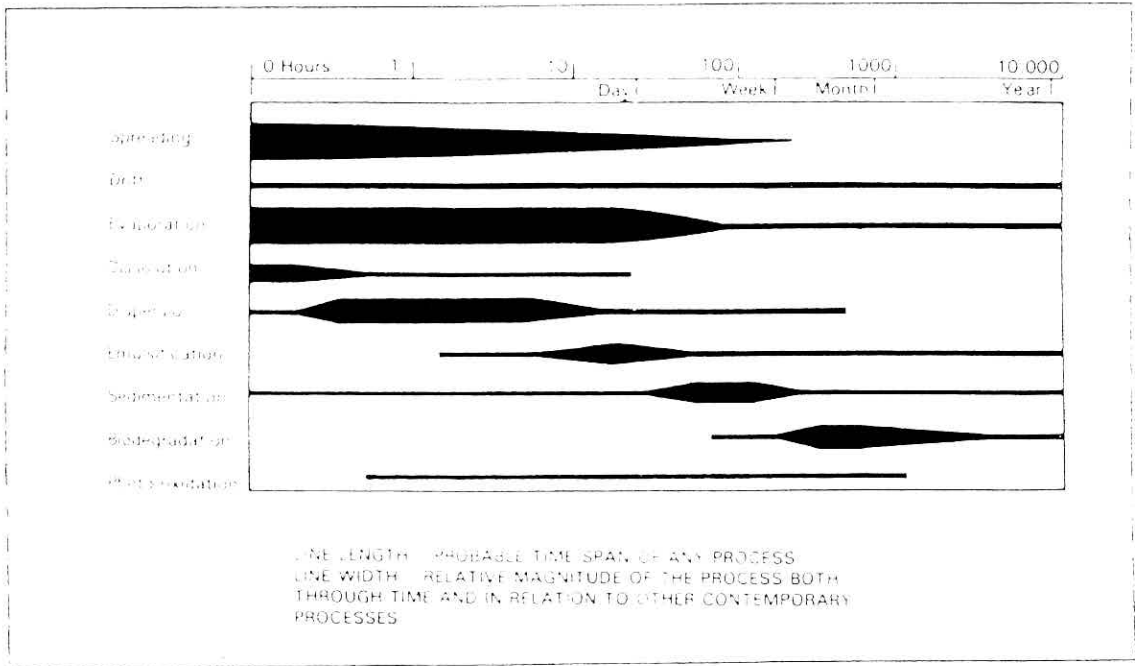

Figure 2 - Time span and relative importance of process acting on an oil spill

2.1 Spreading

Spreading of an oil slick on the sea surface is a rapid and dominant process at the time of a release, decreasing steadily until it has essentially stopped within one to 10 days. Several factors affect spreading. Initially the most important factor will be the volume of oil spilled, provided the oil is above its pour point. A large instantaneous spill will spread more rapidly than a slow discharge.

The surface tension forces between oil, air and water soon begin to influence the spreading. Viscous oils will spread more slowly than oils with low viscosities. Oils spilled on the sea at a temperature below their pour point hardly spread at all. After a few hours the slick begins to break up and form narrow bands or "windrows" parallel to the wind direction. At this stage the oil becomes less important since further spreading is primarily due to turbulence at the sea surface. Spreading rates vary due to differences in the hydrographic conditions such as currents, tidal streams and wind speeds. Some 12 hours after a spill the oil can be scattered within an area of up to five square kilometres, thus limiting the possibility of effective clean-up. It should be appreciated that except in the case of small spills of low viscosity oils, spreading is not uniform and large variations of oil thickness occur within the slick. Waves and turbulence at the sea surface act on the slick to produce droplets with a range of sizes. The larger ones rise back to the surface behind the advancing slick where they usually coalesce to form a ragged tail.

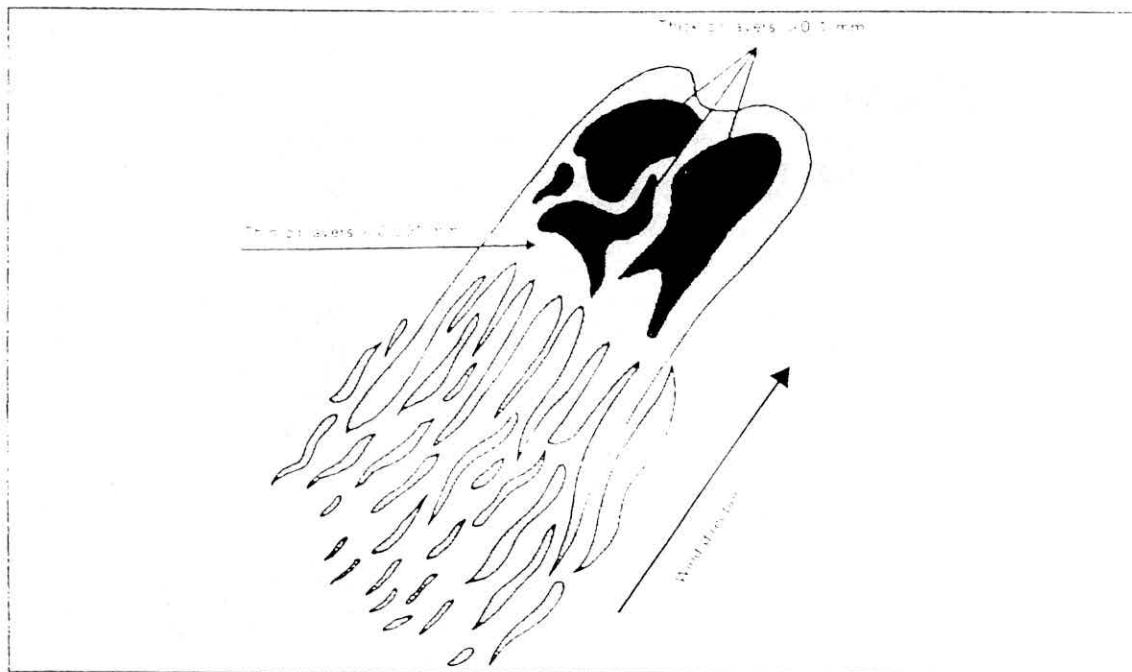

Figure 3 - Spreading of oil on the water

2.2 Evaporation

The most important process removing the oil from the water surface is evaporation. The speed and extent of the evaporation depends mainly on the proportion of low-boiling fractions in the oil. Thus, light oils like gasoline or light fuel oil evaporate very quickly (50% within a few hours). Heavy oils evaporate more slowly and less extensively. Besides the oil type, evaporation rates depend on the amount of spilled oil, the weather conditions and ambient temperatures. As a general rule the higher the wind speed and the ambient temperature, the greater the rate of evaporation.

Volatile components with boiling points up to 200°C will be evaporated within 24 hours. Sometimes light oils may evaporate completely. A major consequence of evaporation will be an increase in density and viscosity of any remaining oil.

2.3 Oil-in-water Emulsions (Natural Dispersion)

Usually liquid oils will disperse as droplets under moderate to rough sea conditions. The oil droplets will diffuse through the upper layers of the sea (natural dispersion) and will be suspended in the water or rise back to the surface depending on the density difference between the oil and water and the size of the droplets. The formation of small oil droplets increases the contact between water and oil enormously and degradation of the oil by micro-organisms is enhanced.

The rate of natural dispersion together with evaporation largely determines the lifetime of oil on the sea surface. Natural dispersion reduces the volume of the oil at the surface and reduces evaporative loss, but it does not lead to changes in the physical and chemical properties of the spilled material in the way that evaporation does. Most small oil slicks at sea will disappear within a few hours through this natural dispersion, providing there is sufficient wave action.

2.4 Water-in-oil Emulsion

Most crude and fuel oils contain sufficient surfactants to create a water-in-oil emulsion quite easily. Energy input is essential and in calm waters little or no emulsification occurs. The amount of dispersed water which can be absorbed by oil can reach 80% by volume.

Water-in-oil emulsion at sea can be formed within a few hours with low viscosity oils but usually takes several days with viscous oils. The most noticeable feature of a stable water-in-oil emulsion is its red-brown or orange colour. Because of its consistency it is often referred to as "chocolate mousse".

The viscosity of water-in-oil emulsions is often much higher than that of the oil from which they were formed. They are usually thixotropic, which means that they may be relatively fluid when being stirred about by waves, etc., but become stiffer when resting on still water or on a beach.

The density also increases and can approach that of seawater. This reduces its buoyancy and if absorption of suspended solids occurs the oil may eventually sink. Taking into account evaporative loss and other dissipative processes the formation of water-in-oil emulsions can increase the volume of the spill by a factor of up to 4. The stability of emulsions depends on the composition of the oil and its temperature. In hot climates emulsions may readily break down

2.5 Other Processes

Other processes also contribute to the fate of spilled oil. The lightest compounds in the oil can, to a certain degree, be dissolved in the water, solar radiation over the oil film can promote oxidation reactions that break large molecules into smaller ones, and some oil components are biodegradable. These processes tend to be more significant in tropical and sub-tropical environments. They are of minor significance to clean-up operations as their combined contribution to the reduction of the volume of oil the water surface or to a change in its properties is very small.

Because the density of both seawater and of oil varies with temperature, the oil may alternate between positive and negative buoyancy. Thus oil may temporarily submerge to a limited depth, only to rise to the surface again within hours or days.

Very few crude oils are sufficiently dense or weathered to such an extent that their residues will sink. Sinking usually brought about by adhesion of particulate matter to the oil. Some heavy crudes, as well as most heavy fuel oils and water-in-oil emulsions require very little particulate matter to exceed the specific gravity of seawater. There is also a possibility of tar lumps forming. Tar lumps or tar balls are compact semi-solid or solid masses of highly weathered oil formed through the aggregation of viscous, high molecular weight hydrocarbons with sediments and debris present in the water column. Tar balls can form anywhere at sea and some of these sink to the bottom as a result of their high specific gravity. They can be transported either floating on the water surface or along the sea-bed and may eventually, arrive on beaches.

In coastal areas, oil may be carried into estuaries and intertidal zones by surface currents and winds and deposited on beaches, mudflats, and marshes. Oil may be transported into and out of the same intertidal zones (or into others) repeatedly through tidal action. Depending upon the characteristics of the sediments (more than one metre depth after one major spill), mixed with surface sediments, or layered on top of the sediment surface in the higher reaches of the intertidal zone

Erosion or scouring of oiled beach sediments may enable oil to enter shallow subtidal zones.

3.0 Movement of Oil Slicks

Oil slick will not usually stay in the same place but will drift under the influence of external factors. The most important of these factors are winds, waves, tides and currents. The transport of water, particularly surface water in the sea, due to wind, waves and currents is difficult topic about which much remains unknown. Friction between wind and water induces a current at the sea surface which is negligible a few millimetres below the surface. The presence of oil on the water surface alters this vertical current profile. Oil on open water will move more quickly than the water directly beneath it, with the result that oil towards the lee side of a slick will be thicker than that to windward. In addition, the slick will rapidly become elongated and will form windrows. The speed with which an oil slick drifts under the influence of the wind depends on wind strength and thickness of oil. Typically it will move at between 2% and 5% of the speed of the speed of the wind measured at 10 metres above the water surface. In open water, 3% of the wind speed is normally used to estimate drift rate.

3.1 The Influence of Currents

If the wind is negligible, which is rarely the case, the oil will move only under the influence of currents or tides. Current regimes may be constant but more commonly vary in strength and direction over time. The strength and direction of tides will influence the movement of the slick in the short term. However, tidal currents rarely cancel each other completely, and this gives rise to a residual current which will determine the long-term movement of the oil slick.

3.2 Assessment of the Drift of a Slick

Having calculated separately the wind induced effect and the surface water current, the movement of a slick on the surface can be determined by drawing a vector diagram. This can be represented by the following simplified formula.

$$V_{oil} = V_{current} + V_{wind} \times Q$$

in which

$$V_{oil} = \text{velocity of the oil}$$

$$V_{current} = \text{velocity of seawater}$$

$$V_{wind} = \text{velocity of wind at the height of 10 metres}$$

$$Q = \text{empirically established wind speed factor (about 3\%)}$$

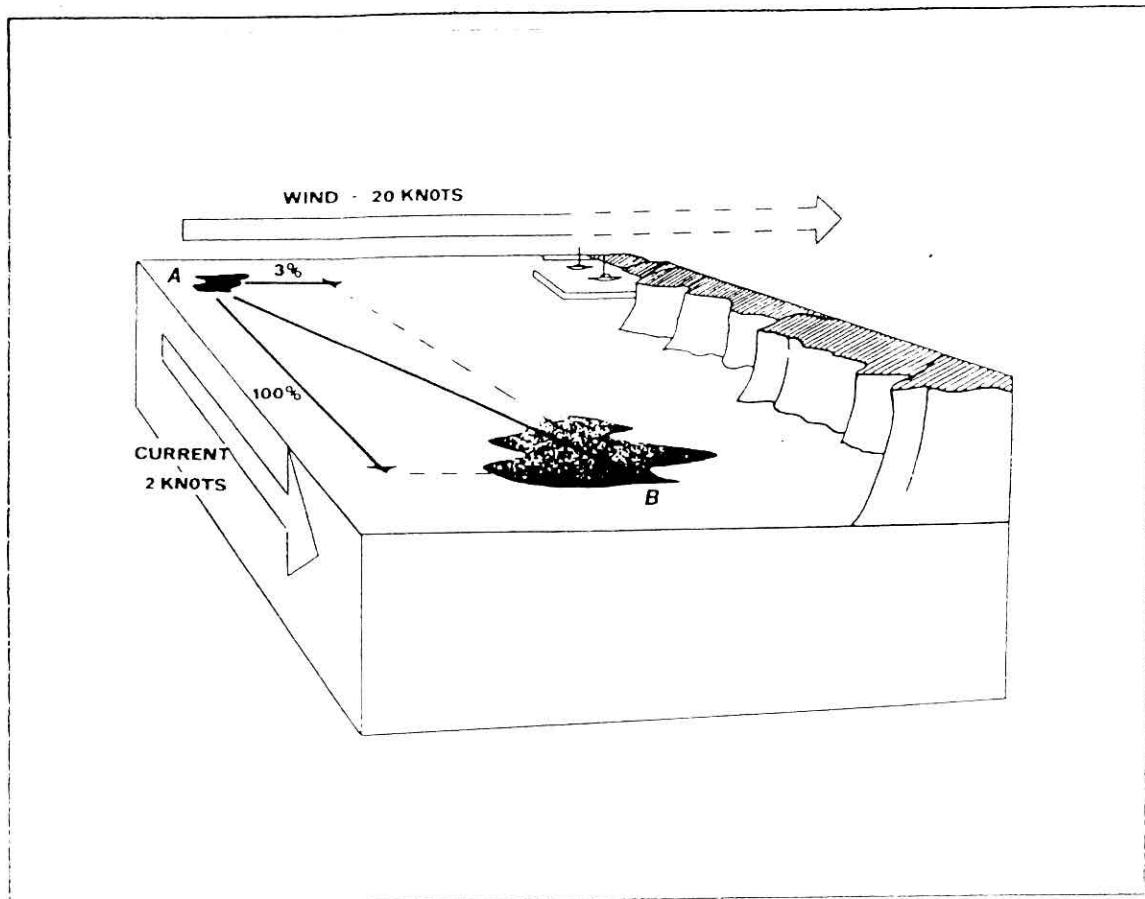

Figure 4 - The influence of 3% of the wind speed combined with 100% of the current speed results in the movement of oil from A to B

3.3 Combined Processes and Modelling

The different processes changing the oil properties and removing it from the water surface have been described briefly. All the processes are dependent on a number of factors, such as oil type temperature, weather conditions etc. They also affect each other. Therefore, it is important to understand how the processes interrelate and hence in a realistic situation, when the type of oil and the ambient conditions are known, to be able to forecast what will happen.

Thus the prediction of the fate of oil spill combined with regular monitoring is one of the most important aspects for an optimal oil spill response.

Many computer models of varying sophistication have been developed for predicting this fate. These models can provide a reliable output if the input information is correct. The result will stand or fall with the input data and this

very information is often not available. However, simple formulae using limited information is often can give adequate prediction and tools such as an oil spill slide rule can be useful for on-scene commanders during cleanup operations.

IKLAS Bahan Kursus

Tajuk Kursus : Kursus Kawalan Tumpahan Minyak
Dan Pembersihan Pantai Negeri Pulau Pinang

**KURSUS KESEDARAN KAWALAN
TUMPAHAN MINYAK DAN
PEMBERSIHAN PANTAI
NEGERI PULAU PINANG**

**Tajuk:
Impak Tumpahan Minyak
Kepada Alam Sekitar**

**Oleh:
Encik Radzuan Yusof**

OIL AND ITS IMPACTS

The effects of a particular spill situation will depend on many factors, including the volume of the oil spilled and its physical, chemical and toxicological characteristics, local condition at the time of the spill, the presence of resources and location of the spill. The variability of these and other factors and their interaction can lead to a wide range of biological, economical and physical effects.

The topic of discussion that follow are not intended to suggest any particular order of priority with regard to effects. The ultimate value placed on various impacts will depend upon the circumstances surrounding the particular spill event.

A distinction should be made at the outset between the effects of spilled oil itself and the effects of clean-up measures. The two major categories of remedial measures are mechanical and chemical. In some instances, these remedial measures may have adverse consequences.

1.0 Impact on Coastal Activities

1.1 Recreational beaches and sea areas

Interference with recreational use and enjoyment of coastal areas is an expected consequence of oil spills. Such occurrence often prohibits boating, bathing and diving in the area, particularly when the oil has washed ashore. As a result, tourism in adjacent coastal communities can be greatly affected. This economic damage is highest if the spill occurs just prior to or during a major tourist season. Impacts are typically short term and recreational activities normally resumes shortly after clean-up has been completed.

For this reason, pressure may be applied by affected coastal communities to facilitate expeditious restoration. However, remedial measures used to achieve this goal may result in long-term adverse consequences to the natural defenses of the coast. Care must be taken to ensure that effects of remedial measures are minimised, and that restoration of amenities is fairly balanced with potential adverse ecological impacts.

1.2 Ports and Marinas

A major oil spill occurring within, or in close proximity to ports and marinas could have far-reaching physical and economic effects. In major ports, the potential for serious economic consequences is high, due to indirect costs associated with measures taken by the designated spill response authority. During the initial assessment of a spill or threat of a spill in a port or marina, the principal concerns that must be addressed are

Spilled oil may cause fire hazards in and around industrial installations and harbours. Activities such as welding, cutting or other spark-generating activities may need to be restricted or prohibited until the fire hazard no longer exists.

Such restrictions and interference may seriously affect normal operation of installations, resulting in short-term economic losses.

2.0 Biological Effects

Depending upon the presence of factors noted in the introduction to this chapter, ecological effects resulting from a spill may include physical and chemical changes in habitats, changes in growth, physiology and behavior of individual organisms and species and destruction or modification of entire communities of organisms through the combined effects of toxicity and smothering.

2.1 Physical Contamination of Biota and Habitat

Floating oil may contaminate mammals and birds that swim or dive through the surface of the water. In the open sea, many birds and animals may be able to avoid contact with an oil slick, but in coastal areas, the organisms may be trapped between the shore and the approaching spill and become contaminated. If fishing activities take place in the immediate vicinity of a spill, both fishing gear and catch are likely to be contaminated as a result of contact with dispersed oil or water-in-oil emulsion that may be floating on the surface, suspended in the water or settled on the sea bottom.

The magnitude and persistence of oil contamination in the intertidal zone depend greatly on the geomorphology and the sediment characteristics of the coast. Steep, exposed rocky coasts tend to deflect the wave energy and hold floating oil away from shore. Long-term effects are likely to be minimal on the ecosystems of such areas, where oil does not persist and rapid recolonisation by plants and animals may occur.

On fine sandy beaches, the oil is likely to remain on the surface where it can be removed. On beaches of cobble, gravel or even coarse sand, the oil may penetrate with the tidal water table down to hard substrata. In sheltered tidal flats, mangroves and salt-marches, oil penetrates into the anoxic muds, facilitated by animal burrows, decaying root masses and interstitial water movement, where it may cause local biological effects for long periods. In such areas, biota are susceptible to physical smothering in the early stages of a spill and are likely to exhibit chemical tainting of their tissues for extended periods.

concentrations may be high enough to affect behavior (e.g. ability to escape predators), growth or reproduction and may lead to disease or early death.

Fish, crustaceans and molluscs that are exposed either to high concentrations of oil, or to moderate concentrations for long periods, may acquire an objectionable, oily odour or flavour, and, as a result, the flesh may be unmarketable. This is a temporary problem since the components causing the taint are lost when normal conditions are restored or when the organisms are maintained in clean water. Depending on the type of oil and prevailing hydrographic and meteorological conditions, tainting may be experienced for periods ranging from a few days to several months. External contamination does not necessarily lead to tainting of the flesh, and will vary as the lipid content and metabolic rates of the organism change with season. Because of the serious economic consequences arising from a loss of sales, considerable care is necessary to prevent contaminated fish and shellfish from reaching the market. Ideally this should involve organised tasting and chemical analysis by qualified personnel at the time of the spill.

2.4 Rates of Recovery

Ecological recovery of a spill-impacted area is not dependent solely on the amounts and composition of contaminants that persist after a spill. Repopulation usually occurs through several phases, involving different species at different times. Recovery rates depend on the population dynamics (reproduction, growth and maturation) and ecological interactions (predation, competition, etc.) of replacement species, well after toxicity has decreased below significant levels.

In general, recovery is very rapid in the water column. Significant effects on plankton populations have not been observed in open water, and those seen in near-shore systems have been local and transitory, with full recovery in a few weeks. Toxicity and malformations have been observed in the floating eggs and larvae of some fish species. However, effects on subsequent year-class strength or overall productivity are unknown because of high natural variability. During the first summer and spring after a major crude oil spill, juvenile flatfish were rare or absent in the near-shore areas that were heavily contaminated. Adult fish in the same areas suffered from fin disease, as well as growth and reproductive disturbances, but effects on region-wide productivity of finfish were small or not detectable.

After initial destruction of intertidal or benthic organisms, resistant or opportunistic species may undergo dramatic population increases and fluctuations in the affected area. Repopulation by the original species may be slow. Some near-shore benthic communities oiled by a major crude oil spill began to show significant recruitment only in the second year and recovery was still not complete after three or four years in the most heavily impacted areas. Damage to

are not more likely to consume oil that was ingested first by their zooplanktonic prey.

3.1.2 Seals and Otters

During pupping season, seals are particularly vulnerable to oil spills. Seal pups may be smothered by thick deposits of oil. Newborn seals possess little fat and depend on their fur for thermal balance, and therefore are susceptible to hypothermia as a result of oil fouling. Because seals are sensitive to all types of disturbances when pups are present, wildlife management officials should be consulted in carrying out clean-up activities near breeding or pupping areas.

Unless otters are quickly and properly cleaned, fouling of their fur is likely to cause death, either through hypothermia or as a result of oil ingestion or aspiration of oil into the lungs during grooming. Although ingestion of oil for short periods usually does not result in serious effects, prolonged consumption may lead to organ damage and hormonal imbalances.

3.1.3 Other Marine Animals

Documented effects of oil spills are rare or non-existent for most other marine mammals, including walruses, whales, porpoises and manatees. Due to their herbivorous habits, ingestion of oil by manatees could disrupt the normal digestive functions of microbes in the gut; however, this has not been documented. Sea turtles are also susceptible to blockage of throat passages by ingested oil and tar balls. Fresh oil is also highly toxic to turtle eggs, especially during the later stages of development, and oil contamination is likely to have significant effects on turtle nesting beaches.

3.2 Marine Birds

Aquatic birds are the most visibly vulnerable to oil spills. Many species depend on the sea and coastal areas for food and nesting habitat. Some species reside permanently in one area, while others migrate seasonally over long distances. Species that spend most of their time on the water are particularly vulnerable to oil spill effects. In addition, some species, (auks and sea ducks) cannot fly during their moulting period, and others (penguins) do not fly at all. Sea-birds may come into contact with floating oil at sea by swimming into the slick, diving through it or surfacing into it from below. Shore birds may also be impacted while feeding on oiled beaches.

the colonies. Once impacted by a spill, local populations may recover quickly if the mortality is minimal.

3.3 Coral Communities and Ecosystems

Less information is available on the vulnerability and sensitivity of corals and coral reef communities to oil spills. Because these diverse communities are important in supporting coastal fisheries, protecting tropical coastlines from wave action and erosion, and providing a basis for tourism and recreation, and because the intrinsic growth rates of hard corals are very slow, a better understanding is needed of the potential long-term effects of oil exposure on these communities.

3.3.1 Effects on Corals

Several oil spills have occurred in the vicinities of coral reefs and near shore-lines with fringing reef communities. These spills have caused substantial mortality among the fishes and invertebrates (including lobsters, crabs, gastropods, bivalves, octopus, sea urchins, sea stars and sea cucumbers) in intertidal areas, on the surfaces and margins of coastal fringing reef platforms, and in adjacent shallow subtidal areas. Natural algal species and sea grasses were also destroyed in many of these areas. In general, the subtidal reef corals themselves seem to survive these individual events. Many corals generate large quantities of mucus when exposed to oil, and this may protect them from more serious damage. Exposure of corals to dispersed oil causes a variety of responses, however, that may influence long-term effects of pollution. Oiling impairs the reproductive process, reducing both the numbers of breeding colonies and the numbers of larvae produced per coral head, and decreasing the rate of larval settlement on artificial substrates. Some coral larvae are ordinarily released only at night and exposure causes premature release of the larvae and decreases chances of their survival. Impaired feeding responses have also been noted in corals exposed to oil. These reproductive and feeding effects may account for decreases in coral and fish diversities observed in areas near oil terminals where there is considerable tanker traffic and where small operational spills may occur.

3.3.2 Recovery Rates

Dense growths of green algae frequently appear in impacted reef zones after the initial mortalities associated with a spill. These blooms probably result from an abundance of available nutrients and the absence of large populations of grazing organisms. After the initial toxicity has dissipated, recruitment of planktonic larvae and adult organisms can begin from

4.3 Long-Term Effects Fish Stocks

Fish stock probably have not been affected significantly by individual oil spills, isolated in time and space from others. While it is clear that large spills can impact local populations or year-classes of fish for periods of up to two years, these effects have not been detectable in regional catch data. The lack of demonstrated effects is due to many factors, including confinement of serious effects to localized areas, ability of adult fish to avoid the spill, ability of adult and juvenile fish to repopulate an impacted area after the spill has dissipated, the dispersion and transport of fish eggs and larvae from adjoining areas, the high degree of natural variability in fisheries populations and in the levels and effects of variability in the catch data, it is unlikely that changes in future catches can be attributable to spill effects, except in extremely localized or confined areas, or in areas subjected to repeated spills and discharges.

4.4 Fish and Shellfish Farming and Seaweed Cultivation

Fish and shellfish that are confined in floating cages or in near-shore enclosures or pens cannot escape from the path of an oil spill, and may suffer mortality or tainting unless they can be removed prior to arrival of the oil. Organisms that may be suspended in the water column beneath floating racks or buoys (e.g. oysters, seaweed, kelp) are less subject to direct mortalities from oil spills. Contamination of these organisms may still occur through bioaccumulation of dispersed or dissolved oil. If bioaccumulation and tainting are minimal, recovery of the harvest may be satisfactory following a period of depuration either on site after the spill has dissipated or by relocation.

Intertidal areas of shellfish culture are particularly susceptible to spill effects. The shore-line effectively traps any oil that may be transported there and holds it while successive tides deposit and redeposit it in the intertidal zone. Wave action may disperse the oil throughout the shallow water column and mix it into sediment layers. Together, these processes can cause direct physical contamination of the shellfish; bioaccumulation and tainting of the edible tissues; and persistent chemical contamination of the sediment, rendering the environment potentially unsuitable for shellfish production for several years. In areas remote from the spill, shellfish may be saved by immediate harvest before the spill arrives. Shellfish in moderately contaminated areas may be relocated to clean areas for depuration or cleansing of the tissues. Shellfish in more heavily contaminated areas might have to be destroyed.

Economically important algae and other plants in the intertidal zone may be broken away from their rocky substrata by the weight of oil clinging to the fronds. Small decreases in population density may occur for a year after the spill. Cultured seaweed grown on floating nets are particularly prone to contamination

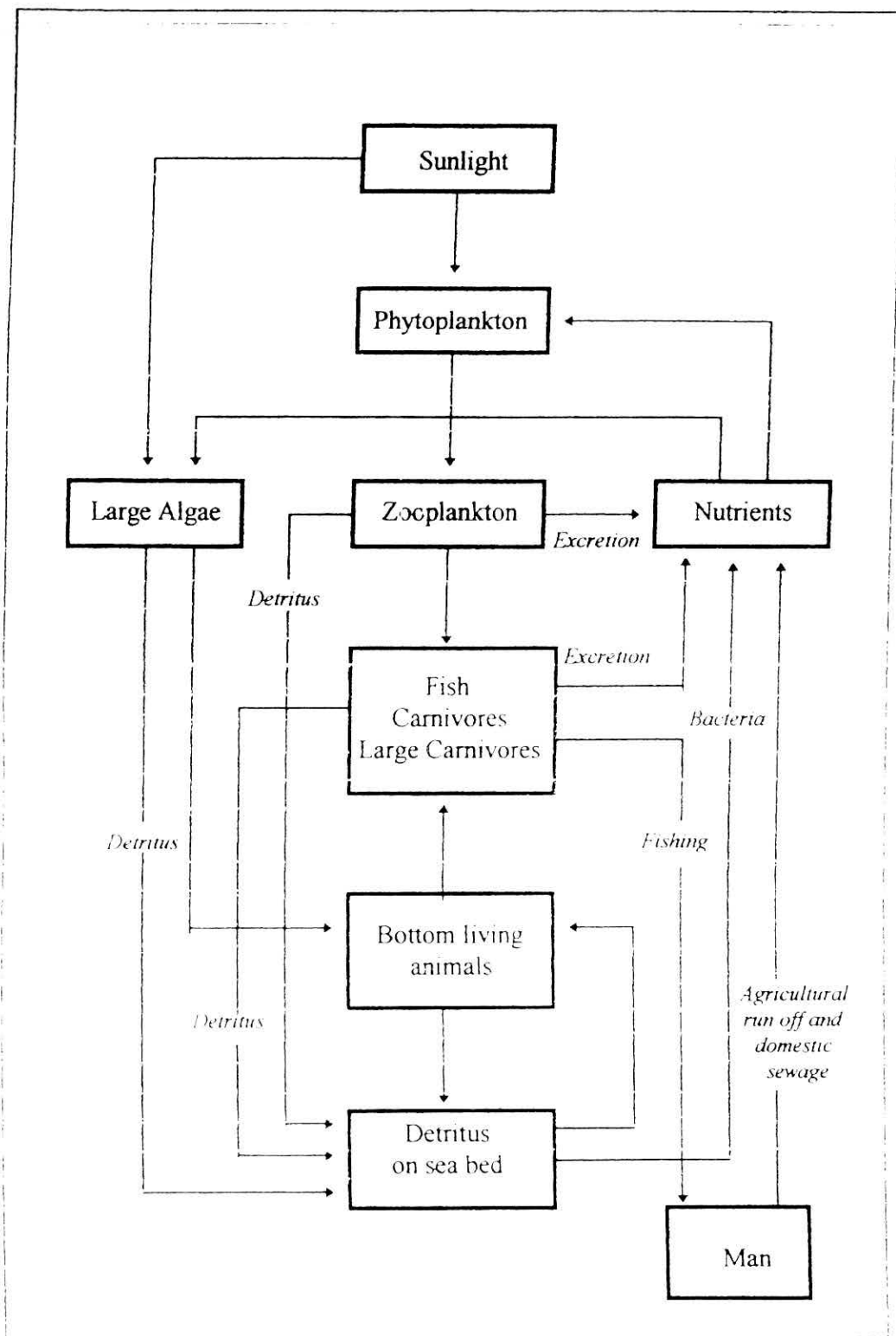

Figure 5 - Food cycle based on 'Oil pollution and marine ecology'

WHAT IS OIL ?

✓ Crude

✓ PRODUCT

- Gasoline/Petrol
- Kerosene
- Diesel
- Fuel Oil



OIL CATEGORY

PERSISTENT OIL

↳ DISSIPATE SLOWLY AND REMAINED ON THE SEA SURFACE

↳ USUALLY REQUIRE A CLEAN UP OPERATION
eg. CRUDE

NON PERSISTENT OIL

↳ TEND TO DISAPPEAR RAPIDLY FROM THE SEA SURFACE

eg. GASOLINE, NAPHTHA, KEROSENE



OIL CHARACTERISTICS

✓ SPECIFIC GRAVITY
(ITS DENSITY IN RELATION TO PURE WATER)

✓ FLASH POINT
(THE TEMPERATURE ITS VAPOUR WILL IGNITE)

✓ VISCOSITY
(ITS RESISTANCE TO FLOW) (Centistokes (cSt))



OIL CHARACTERISTICS

- ✓ **POUR POINT**
THE TEMPERATURE BELOW WHICH AN OIL
WILL NOT FLOW
- ✓ **SOLUBILITY**
ABILITY TO DISSOLVE IN A GIVEN SOLVENT
- ✓ **ASPHALTENE**
PROPENSITY TO EMULSIFY



SOURCES OF PETROLEUM INTO MARINE ENVIRONMENT

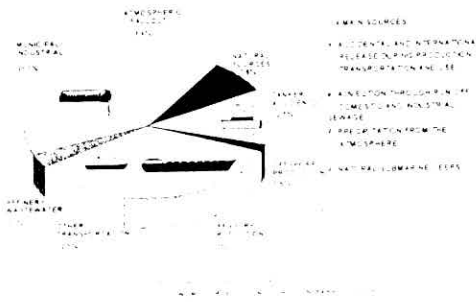

FATE OF OIL SPILLS

Factors affecting behaviour of oil

- Physical characteristics
- Composition & chemical characteristics
- Meteorological conditions
- Characteristics of the sea



FATE OF OIL SPILLS

PROCESSES

1. Spreading & Movement

- appearance & thickness
- wind, tides, current
- debris



FATE OF OIL SPILLS

Spread of Oil due to wind

(Windrose)

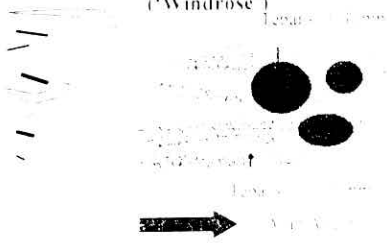

FATE OF OIL SPILLS

2. Weathering Processes

- Evaporation
- Dissolution
- Emulsification
 - oil in water
 - water in oil



'FATE OF OIL SPILLS'

2. Weathering Processes (Cont)

- Oxidation
- Biodegradation

3. Other Processes

- Ingestion
- Sedimentation



FATE OF OIL AT SEA

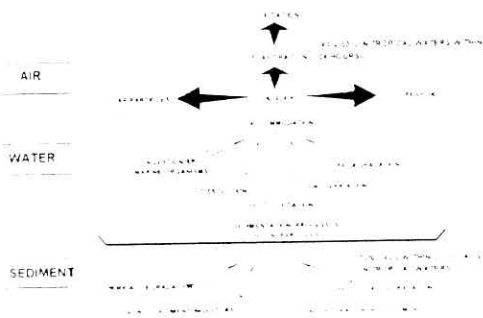

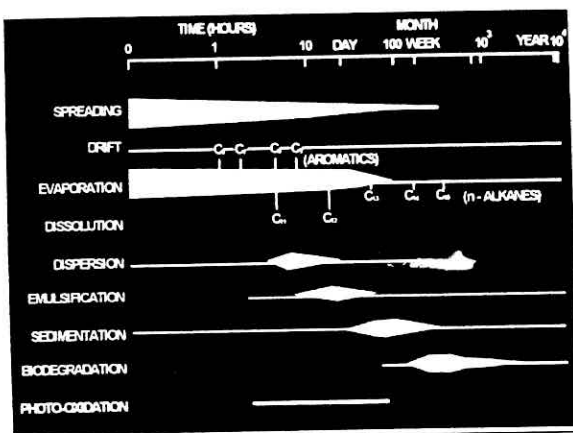

FATE OF OIL SPILLS

Wind & Current Effects

$$V_{oil} = V_{current} + V_{wind} \times Q$$

where:

- V_{oil} - speed of oil
- $V_{current}$ - current speed
- V_{wind} - wind speed
- Q - wind speed factor (3%)



Effect of Wind & Current

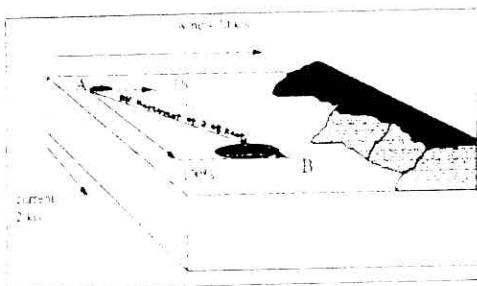

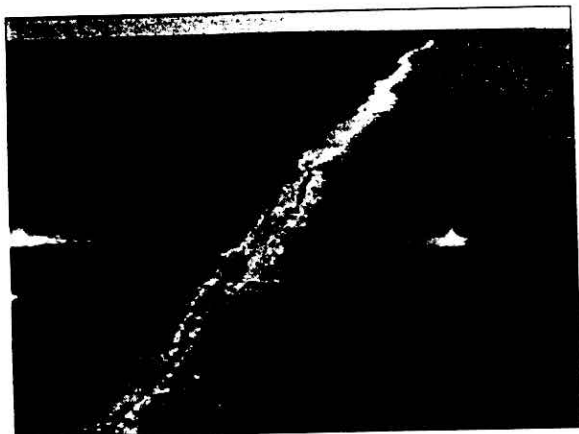



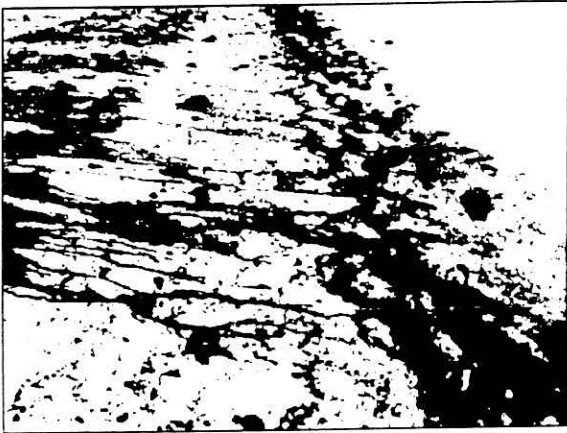

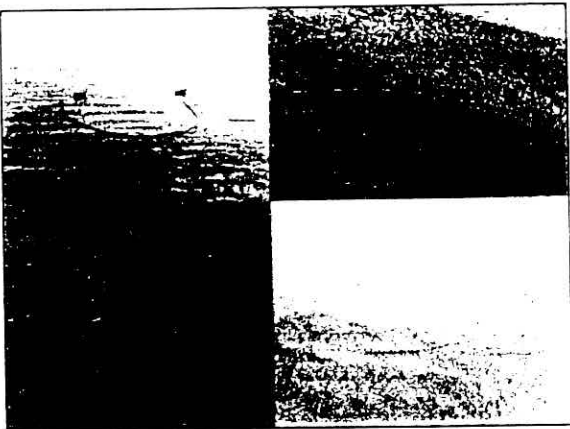

IMPACT

Broadly classified into four:

I M P A C T	▶	<ul style="list-style-type: none"> • Ecological • Economic • Physical • Reputation
----------------------------	---	--

EFFECTS OF OIL SPILLS

Ecological Effects depends on:

- Oil type
- Oil Loading
- Geographical/Geological
- Climate, weather, season
- Biological

EFFECTS OF OIL SPILLS

Biological Factors:

- └ Different species different sensitivities
- └ - Algae vs birds, mangroves, corals
- └ Different life stages
- └ Impact of oil on key species
- └ Recovery relies on recolonization

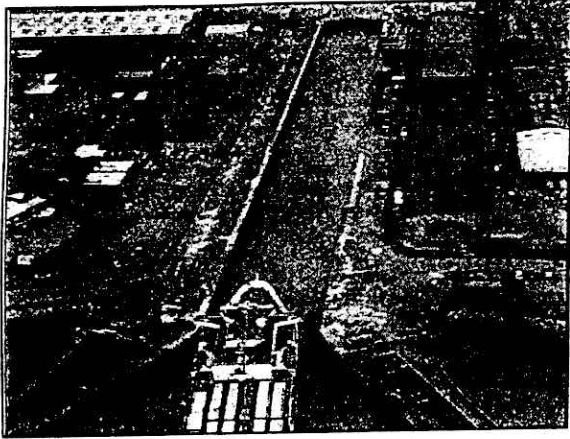

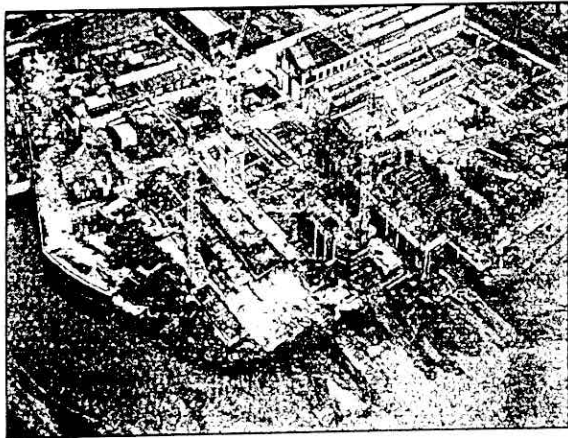

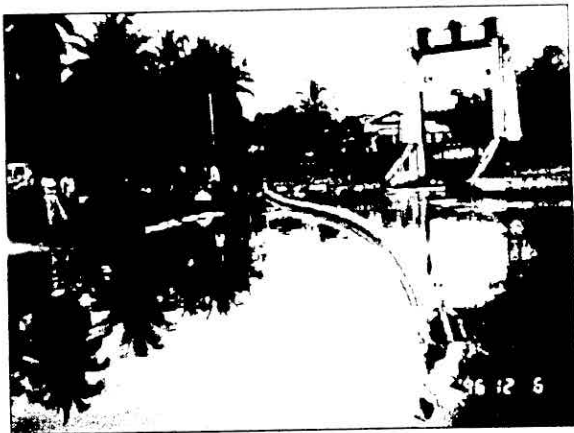

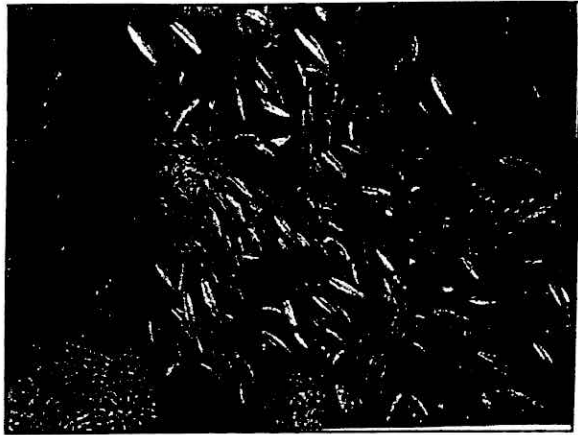







IKLAS Bahan Kursus

Tajuk Kursus : Kursus Kawalan Tumpahan Minyak
Dan Pembersihan Pantai Negeri Pulau Pinang

**KURSUS KESEDARAN KAWALAN
TUMPAHAN MINYAK DAN
PEMBERSIHAN PANTAI
NEGERI PULAU PINANG**

Tajuk:
**Aspek Keselamatan Di Dalam Operasi
Mengawal Tumpahan Minyak**

Oleh:
Encik Radzuan Yusof

KURSUS KESEDARAN KAWALAN TUMPAHAN MINYAK
DAN PEMBERSIHAN PANTAI
ZON SELATAN
11-13 OKTOBER 1999

HEALTH AND SAFETY ASPECTS
IN OIL SPILL CLEAN UP OPERATION

MOHD RADZUAN YUSOF
PETRONAS

Personal Safety

- Proper attire -Personal Protective Equipment
- Healthy
- Properly trained personnel - equipment
- Familiar with Hazard Data Sheet and Safety Procedure
- To have basic first aid knowledge



Personal Safety (Cont.)

- Avoid working rigorously
- Avoid working alone
- Accident - report to supervisor



Operation

Shoreline:

- Be aware of tidal conditions
- Extra careful on loose surfaces
- Use staging and life lines on cliff faces



Operation

At Sea:

- Proper clothing for adverse weather
- Take measures to control sea sickness
- Do not interfere with vessel equipment
- Avoid cramped working conditions
- Keep clear of rotating equipment



Operation

- In hot weather - take a lot of water
- Avoid oil fume
- Avoid gasoline as cleaning agent
- Refrain from smoking

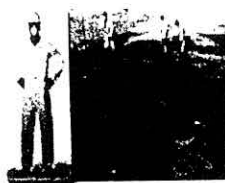

Operation

- Wipe off small spill immediately
- Use proper waste disposal
- Contact with chemical - wash with water



Communication

- Familiar with equipment
- Do not use unnecessarily
- Confirm channel before hand
- Use hands free kit
- Check battery fully charge



THANK YOU

IKLAS Bahan Kursus

Tajuk Kursus : Kursus Kawalan Tumpahan Minyak
Dan Pembersihan Pantai Negeri Pulau Pinang

**KURSUS KESEDARAN KAWALAN
TUMPAHAN MINYAK DAN
PEMBERSIHAN PANTAI
NEGERI PULAU PINANG**

Tajuk:

**Oleh:
PIMMAG**

IKLAS Bahan Kursus

Tajuk Kursus : Kursus Kawalan Tumpahan Minyak
Dan Pembersihan Pantai Negeri Pulau Pinang

**KURSUS KESEDARAN KAWALAN
TUMPAHAN MINYAK DAN
PEMBERSIHAN PANTAI
NEGERI PULAU PINANG**

**Tajuk:
Pelan Tindakan Dan Operasi
Pembersihan Pantai**

**Oleh:
JAS PULAU PINANG**

IKLAS Bahan Kursus

Tajuk Kursus : Kursus Kawalan Tumpahan Minyak
Dan Pembersihan Pantai Negeri Pulau Pinang

**KURSUS KESEDARAN KAWALAN
TUMPAHAN MINYAK DAN
PEMBERSIHAN PANTAI
NEGERI PULAU PINANG**

**Tajuk:
Rancangan Kontingensi
Kebangsaan**

**Oleh:
Dr. Zulkifli Abdul Rahman**

2. Rancangan Koningensi Kebangsaan (RKK)

2.1 Skop

RKK telah dirangka untuk merangkumi tumpahan yang berlaku di semua kawasan di perairan Malaysia sama ada di Selat Melaka, Laut China Selatan dan Teluk Brunei, Perairan di Sabah dan Sarawak dan Laut Sulawesi yang berhampiran dengan Sabah serta kawasan-kawasan lain dalam perairan negara termasuklah Zon Eksklusif Ekonomi (ZEE).

2.2 Objektif

Pelan ini merupakan satu garis panduan dalam menangani tumpahan minyak serta untuk memenuhi objektif berikut.

- i) Mengadakan satu sistem tindakbalas serta-merta yang diselaraskan bagi menghadapi kejadian tumpahan minyak;
- ii) Mempertingkatkan kemampuan dengan sumber-sumber yang ada dari segi peralatan dan kursus serta latihan kakitangan bagi menghadapi kejadian tumpahan minyak; dan,
- iii) Mengelakkan kesan-kesan ke atas alam sekitar dengan cara mengawal pengaliran tumpahan minyak.

2.3 Peringkat Tindakbalas

PKK dilaksanakan secara beringkat mengikut:

- i) Lokasi kejadian tumpahan;
- ii) Kuantiti tumpahan; dan
- iii) Keupayaan dan kemampuan untuk bertindak.

Setiap peringkat bertindak berhubungkait di antara satu dengan lain dan tindakan yang diambil akan berpandukan kepada rancangan-rancangan kontingensi berkaitan yang sedia ada. Tindakan di tiap-tiap peringkat mungkin berjalan serentak bergantung kepada faktor-faktor di atas dan peringkat-peringkat tindakan adalah seperti berikut:

2.3.1 Peringkat Pertama - Tindakan Tempatan

Tindakan pembersihan tumpahan minyak di peringkat ini akan dilaksanakan oleh pengusaha tempatan di mana tumpahan berlaku seperti di kawasan pelabuhan, terminal atau depoh pengendalian minyak serta pelantar-pelantar carigali minyak dengan memanfaatkan keupayaan kakitangan serta peralatan tempatan yang sedia ada. Tumpahan di peringkat ini biasanya kecil dan tindakan akan berpandukan kepada rancangan kontingensi tempatan masing-masing.

2.3.2 Peringkat Kedua - Tindakan Negeri

Tindakan Peringkat Kedua ini akan digerakkan setelah didapati keupayaan kakitangan dan peralatan Peringkat Pertama tidak mencukupi bagi mengawal tumpahan minyak dan bantuan dari lain-lain negeri diperlukan. Di samping itu juga, mobilisasi Peringkat Kedua ini akan dilaksanakan bila tumpahan berlaku di luar skop rancangan kontingensi tempatan (peringkat pertama), iaitu di luar batas keupayaan atau lingkungan rancangan kontingensi tempatan. Bantuan ini diselaraskan dengan menggerakkan rancangan-rancangan kontingensi Negeri dan Jawatankuasa-Jawatankuasa Operasi Negeri berkenaan untuk memastikan langkah-langkah wajar mengawal tumpahan dapat diambil.

Mengikut draf terakhir yang disediakan dan tertakluk kepada persetujuan JK RKK, Rancangan Kontingensi Negeri dengan Jawatankuasa Operasi Negeri terdiri daripada 12 buah negeri di seluruh Malaysia kecuali Negeri Perlis yang digabungkan bersama dengan Negeri Kedah.

2.3.3 Peringkat Ketiga - Tindakan Wilayah

Peringkat ini melibatkan tindakan bagi mengawal kejadian tumpahan minyak yang besar di mana keseluruhan tenaga dan sumber-sumber yang terdapat di negara ini tidak memadai dan bantuan dari negara-negara lain diperlukan. Gerakan peringkat ini juga akan dilaksanakan bilamana tumpahan minyak merebak ke perairan negara-negara jiran. Penyelarasan bantuan antarabangsa di peringkat ini akan dilaksanakan oleh Jawatankuasa Kebangsaan Kawalan Tumpahan Minyak berdasarkan prosedur-prosedur rancangan-rancangan kontingensi wilayah yang berkaitan. Di antara rancangan-rancangan kontingensi wilayah tersebut adalah seperti berikut:

- i. 'ASEAN - Oil Spill Response Action Plan (ASEAN - OSRAP)';
- ii. 'Standard Operating Procedure for Joint Oil Spill in the Straits of Malacca and the Straits of Singapore';
- iii. 'Standard Operating Procedure for Malaysia and Brunei Darussalam'; dan
- iv. 'Cooperative Network for Oil Spill Countermeasure in the Lombok/Makassar Straits and Sulawesi Sea'.

Di bawah Rancangan Kontingensi Wilayah ini, Jabatan Alam Sekitar adalah agensi yang bertanggungjawab sebagai agensi penyelaras (focal point) dan Jabatan Laut adalah sebagai agensi pelaksana.

3. ORGANISASI RANCANGAN

Terdapat beberapa Jawatankuasa yang diwujudkan untuk memastikan kelancaran pelaksanaan pelan RKK ini.

3.1. JAWATANKUASA KEBANGSAAN KAWALAN TUMPAHAN MINYAK (JKKTM)

Di Peringkat Pertama dan Kedua, pelaksanaan tindakan akan berpandukan kepada rancangan-rancangan kontingensi terlibat atau penyelarasan oleh jawatankuasa-jawatankuasa operasi Negeri.

Di Peringkat Tindakan Ketiga, pelaksanaan rancangan kontingensi akan diarah oleh Jawatankuasa Kebangsaan Kawalan Tumpahan Minyak (ketetapan Jemaah Menteri pada 23 Jun 1976) bertempat di Jabatan Alam Sekitar, Tingkat 13, Wisma Sime Darby, Kuala Lumpur. Berikut ialah peranan yang di antara lain boleh dimainkan oleh agensi-agensi yang menganggotai JKKTM:

Agensi	Tanggungjawab
Jabatan Alam Sekitar	Pengerusi, Sebagai Penyelaras Kawasan.
Jabatan Laut	Memberi nasihat teknikal berhubung kapal-kapal terlibat dengan tumpahan minyak dan pemeriksaan di samping menyediakan kemudahan kapal-kapal, peralatan serta kakitangan di dalam operasi mengawal tumpahan dan penguatkuasaan.
Jabatan Perikanan	Memberi nasihat teknikal berhubung industri perikanan serta menyediakan kemudahan kapal-kapal dan kakitangan di dalam operasi melawan tumpahan minyak dan penguatkuasaan.
Jabatan Perkhidmatan Kaji cuaca	Menasihati dan memberikan maklumat mengenai keadaan cuaca.

Jabatan Kastam dan Eksais Diraja	Membantu memudahkan pergerakan peralatan dan kakitangan melawan tumpahan minyak dari luar negara.
Jabatan Imigresen	Membantu memudahkan pergerakan kakitangan melawan tumpahan minyak dari luar negara dan penguatkuasaan.
Markas Tentera Laut	Pengawasan laut dan penguatkuasaan.
Pasukan Polis Marin, Polis Diraja Malaysia	Pengawasan laut dan penguatkuasaan.
Markas Tentera Udara	Pengawasan udara, pengangkutan serta pengendalian 'dispersant' melalui udara dan penguatkuasaan.
Unit Udara, Polis Diraja Malaysia	Pengawasan udara, pengangkutan melalui udara dan penguatkuasaan.
Kementerian Luar Negeri	Memberi nasihat dan menyelaras perhubungan dengan negara-negara lain jika bantuan negara luar diperlukan.
Bahagian Keselamatan Negara	Memberi nasihat berhubung isu-isu keselamatan dan menyelaras perhubungan dan tindakan dengan Jawatankuasa Keselamatan Negeri (JKKN) serta menyelaras kerja-kerja pembersihan pantai yang akan melibatkan Penguasa Penguasa Tempatan. Menyelaras isu-isu dasar jangka masa panjang yang memerlukan perhatian dan keputusan Majlis Maritim Kebangsaan (MMK).
Pusat Penyelarasan Penguatkuasaan Maritim	Memberi nasihat serta menyelaras aktiviti-aktiviti agensi-agensi penguatkuasaan maritim.
Jabatan Bomba dan Penyelamat	Membantu kerja-kerja penyemburan "oil spill dispersant" dan memberi khidmat nasihat dalam hal-hal kebakaran dan menyelamat.
Petroleum Nasional Berhad (PETRONAS)	Memberi khidmat nasihat berkaitan tumpahan minyak.
Petroleum Industry of Malaysia Mutual Aid Group (PIMMAG)	Memberi nasihat teknikal peralatan dan operasi mengawal tumpahan minyak.

3.2. JAWATANKUASA-JAWATANKUASA OPERASI NEGERI (JON)

Untuk menyelaraskan operasi melawan tumpahan Peringkat Kedua, Jawatankuasa Operasi Negeri akan dibentuk dan di pengkerusi oleh pegawai yang akan dilantik oleh Ketua Pengarah Kualiti Alam Sekeliling selaku Pengerusi Jawatankuasa Kebangsaan Kawalan Tumpahan Minyak. Ahli-ahli Jawatankuasa ini akan bergantung kepada keperluan operasi. Peranan yang dimainkan oleh Jawatankuasa ini adalah menyerupai peranan Jawatankuasa Kebangsaan Kawalan Tumpahan Minyak.

3.4. KAKITANGAN UTAMA

3.4.1 Penyelaras Kawasan

Perwakilan Penyelaras Kawasan adalah tertakluk kepada lokasi kejadian tumpahan. Penyelaras Kawasan adalah terdiri dari Pengarah-Pengarah Jabatan Alam Sekitar Negeri.

Peranan Penyelaras Kawasan di antara lain adalah seperti berikut:

- Menjalankan penyiasatan berhubung kejadian tumpahan secepat mungkin dan mengemukakan laporan siasatan kepada Ketua Pengarah Kualiti Alam Sekeliling;
- Mengambil langkah-langkah awal mencegah tumpahan dari terus merebak dengan menggerakkan kakitangan dan peralatan sedia ada. Untuk kejadian tumpahan di kawasan pelabuhan, terminal atau depoh pengendalian minyak dan pelantar-pelantar minyak, Penyelaras Kawasan hendaklah menggerakkan serta mengawalselia pergerakan Tindakan Peringkat Tempatan;
- Bertanggungjawab mendapatkan contoh-contoh bahan tumpahan serta mengemukakan contoh tersebut kepada Jabatan Kimia untuk dianalisa;

- Mendapatkan bon jaminan bagi pihak Ketua Pengarah Kualiti Alam Sekeliling dari pihak pencemar sebagai memenuhi kos pembersihan dan gantirugi yang ditanggung akibat dari tumpahan;
- Bagi kejadian tumpahan minyak yang besar, Penyelaras Kawasan akan menyelaras semua bentuk bantuan yang diperlukan oleh 'Pemerintah Tempat Kejadian' dan Penyelaras Pembersihan Pantai;
- Mengumpul laporan aktiviti harian dari 'Pemerintah Tempat Kejadian' dan Penyelaras Pembersihan Pantai untuk tujuan memudahkan proses tuntutan kos pembersihan tumpahan dan gantirugi; dan

3.4.2 'Pemerintah Tempat Kejadian' (On-Scene Commander)

Peranan 'Pemerintah Tempat Kejadian' akan dilaksanakan oleh Pegawai Pemerintah mana-mana kapal agensi-agensi Kerajaan yang pertama sampai ke tempat kejadian. Untuk kejadian di kawasan-kawasan yang dilingkungi oleh rancangan-rancangan kontingensi, perlantikan 'Pemerintah Tempat Kejadian' tertakluk kepada kaedah perlantikan rancangan kontingensi tersebut.

Walau bagaimanapun, Jawatankuasa Operasi Negeri atau Jawatankuasa Kebangsaan Kawalan Tumpahan Minyak berhak melantik semula 'Pemerintah Tempat Kejadian' jika perlu.

Peranan 'Pemerintah Tempat Kejadian' di antara lain adalah seperti berikut:

- Bertanggungjawab ke atas pengurusan aktiviti melawan tumpahan minyak di tempat kejadian serta tugas-tugas penyelarasan dengan Penyelaras Kawasan;

- Bertanggungjawab ke atas penyaluran maklumat dan menerima arahan dari pusat kawalan operasi untuk tindakan susulan;
- Menyediakan laporan harian perjalanan operasi serta mengemukakannya kepada Penyelaras Kawasan untuk memudahkan proses tuntutan kos pembersihan tumpahan dan gantirugi; dan
- Bertanggungjawab ke atas soal-soal keselamatan semasa operasi pembersihan di laut

3.4.3. Penyelaras Pembersihan Pantai

Di Peringkat Kedua dan Ketiga Penyelaras Pembersihan Pantai adalah Jawatankuasa Pembersihan Pantai yang ditubuhkan di peringkat negeri dimana pengerusi jawatankuasa adalah terdiri dari Setiausaha Kerajaan Negeri

Penyelarasan pembersihan pantai di Peringkat Pertama adalah tanggungjawab pihak berkuasa pelantar minyak, kemudahan pengendalian minyak (depoh, terminal) serta pelabuhan.

Peranan Penyelaras Pembersihan Pantai di antara lain adalah seperti berikut:

- Bertanggungjawab ke atas pengurusan aktiviti pembersihan pantai serta tugas-tugas penyelarasan dengan Penyelaras Kawasan;
- Bertanggungjawab ke atas penyaluran maklumat dan menerima arahan dari pusat kawalan operasi untuk tindakan susulan;
- Menyediakan laporan harian perjalanan operasi serta mengemukakannya kepada Penyelaras Kawasan untuk memudahkan proses tuntutan kos pembersihan dan gantirugi; dan

- Bertanggungjawab ke atas soal-soal keselamatan semasa operasi pembersihan di pantai.

4. PUSAT-PUSAT KAWALAN

4.1 Pusat Kawalan Tumpahan Minyak Kebangsaan

Bilik Kawalan bertempat di Ibu Pejabat, Jabatan Alam Sekitar, Tingkat 12, Wisma Sime Darby, Kuala Lumpur akan berfungsi sebagai Pusat Kawalan Tumpahan Minyak Kebangsaan di mana semua perhubungan samaada laporan berhubung perjalanan operasi pembersihan, permohonan peralatan dan sebagainya akan disalurkan.

4.2 Pusat Kecil Kawalan Tumpahan Minyak

Pusat ini berfungsi sebagai pusat kawalan tumpahan di mana semua perhubungan di antara 'Pemerintah Tempat Kejadian' dengan Penyelaras Kawasan akan disalurkan. Pusat ini akan ditentukan oleh Jawatankuasa Kebangsaan Kawalan Tumpahan Minyak berdasarkan kepada perkara-perkara berikut:

- i. Kedudukan yang berdekatan dengan tempat kejadian; dan
- ii. Kemudahan perhubungan.

5. PERHUBUNGAN AWAM

Segala bentuk kenyataan media berhubung dengan kejadian pencemaran hanya boleh dikeluarkan oleh Pengerusi Jawatankuasa Kebangsaan Kawalan Tumpahan Minyak, Pengerusi Jawatankuasa-Jawatankuasa Kawalan Operasi Negeri, dan Pengawal-Pengawal Rancangan-Rancangan Kontingensi Tempatan. Penyelaras Kawasan,

Pemerintah Tempat Kejadian dan Penyelaras Pembersihan Pantai dibenarkan mengeluarkan kenyataan media dengan kebenaran dari Pengerusi Jawatankuasa Kebangsaan Kawalan Tumpahan Minyak, Pengerusi Jawatankuasa Kawalan Operasi Negeri terlebih dahulu.

6. PENUTUP

Tindakbalas yang pantas dan tersusun adalah penting untuk meminimalkan kemusnahan alam sekitar. Melalui persefahaman dan kerjasama antara pihak industri minyak dan agensi-agensi kerajaan, sumber-sumber tenaga kerja dan peralatan dalam tindakbalas dapat disediakan mengikut keadaan operasi dan saiz tumpahan yang berlaku. Di samping itu juga, penyelarasan antara badan atau agensi kerajaan, telah membuktikan kejayaan dalam usaha mengawal tumpahan minyak.



**RANCANGAN KONTINGENSI
KEBANGSAAN KAWALAN
TUMPAHAN MINYAK**

**OLEH:
JABATAN ALAM SEKITAR
KUALA LUMPUR**

RKK - Sejarah

- Edisi Pertama (1976) - Pembentukan selepas dua kejadian tumpahan minyak yang besar di Selat Melaka.
- Edisi Kedua (1986) - Perkembangan Petroleum E&E di Laut China Selatan.
 - Edisi Ke Tiga (1989) - Gabungan kedua-dua pelan.
 - Edisi Ke Empat (1994) - Semakan selepas kejadian tumpahan dari kapal Nagasaki Spirit 1992.
 - Edisi Ke Lima (1999) - Semakan selepas kejadian tumpahan dari kapal Evoikos 1997

RKK (Bab I) - Pengenalan.

Undang-Undang

- Seksyen 27, 46, 47 & 48 of AKAS '74
- Part V of MSO '52
- Seksyen 10, 11, 12, 13, 14, 15 & 40 of ZEE '84
- Seksyen 26 of Fisheries Act '85

Konvensyen

- MARPOL 73/78
- OPRC '90
- CLC 1960 & FUND 1971

RKK (Bab I) - Pengenalan.

Skop

- Perairan Malaysia
- Perairan Zon Ekonomi Exclusive Malaysia

RKK (Bab I) - Pengenalan.

SKOP GEOGRAFI RANCANGAN KONTINGENSI KEBANGSAAN KAWALAN TUMPAHAN MINYAK

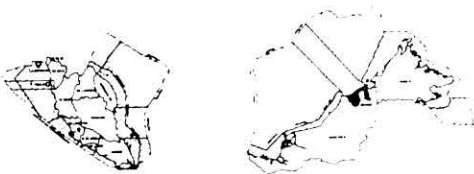

RKK (Bab I) - Pengenalan.

Objektif

- Untuk mengadakan satu sistem tindakbalas serta merta
- Untuk mempertingkatkan kemampuan sumber dari segi peralatan dan kakitangan.
- Untuk mengelak kesan buruk ke atas persekitaran

RKK (Bab II) - JKKTM

Ahli Jawatankuasa Kebangsaan Kawalan Tumpahan Minyak (JKKTM)

- DOE
- MARDEP
- Fisheries
- Meteorological
- Royal Malaysia Navy
- Royal Malaysia Airforce
- Royal Police
- Air Wing Unit
- Custom & Excise
- Immigration
- Wisma Putra
- National Security Div.
- MECC
- PETRONAS
- PIMMAG
- Fire & Rescue*

RKK (Bab III) - Pelaksanaan

Prosedur Melapor

- Obligasi untuk melapor kepada JAS
- Laporan awal harus mengandungi " where, what, when & how "

Penyasatan awal

- akan dilaksanakan oleh JAS Negeri sebagai penyelaras kawasan.
- Dalam tempoh 12 jam dari tarikh kejadian.
- Maklumat terperinci mengenai kejadian

RKK (Bab III) - Pelaksanaan

Pentilaian

- Berasaskan laporan siasatan & pengawasan JKKTM akan menentukan
 - Peringkat Tindakbalas
 - On-Scene Comander
 - Penyelaras Pantai
 - Sub - Bilik Kawalan

RKK (Bab III) - Pelaksanaan

- Dapatkan bank Gerenti
 - To cover cleanup cost
- Salvage & cargo transfer
 - In accordance with Part X, MSO 1952
- Prosedur mendapat bantuan luar
 - Diselaraskan oleh RKKTM
- Laporan dan Tuntutan
 - Lengkap dan supported with documents

RKK (Bab IV) - Teknik

- Containment & recovery
 - Preferred method
- The use of chemical agents
 - Prior approval from DOE
- Beach cleanup & disposal
 - Approved method
- Leave alone & monitor
 - Continuous surveillance

RKK (Bab V) - Lain-Lain Hal

- Safety of personnel
 - PPE, SOP & manpower management
- Public relation
 - Avoid misleading & speculative report
- Training & exercise
 - Training & drill program
- Amendment & review
 - Enhance effectiveness of contingency plan

RKK - Hubungkait dengan lain-lain Pelan

- Pelan Tempatan - ports, terminals, depots etc.
- Pelan Negeri
- Pelan Kebangsaan
- Pelan Multi/Bilateral:
 - SOP Malacca & Singapore Straits
 - SOP Brunei Bay
 - SOP Sulu Sea
- Pelan Wilayah
 - ASEAN-OSRAP

IKLAS Bahan Kursus

Tajuk Kursus : Kursus Kawalan Tumpahan Minyak
Dan Pembersihan Pantai Negeri Pulau Pinang

**KURSUS KESEDARAN KAWALAN
TUMPAHAN MINYAK DAN
PEMBERSIHAN PANTAI
NEGERI PULAU PINANG**

**Tajuk:
Rawatan, Pengangkutan Dan
Pelupusan Sisa Minyak**

**Oleh:
Puan Mariana Md. Nor**

RAWATAN, PENGANGKUTAN DAN PELUPUSAN SISA MINYAK¹

**Mariana Md Nor
Bahagian Kawalan
Jabatan Alam Sekitar**

PENGENALAN

Perairan Malaysia terutamanya kawasan Selat Melaka dan Laut China Selatan sememangnya terkenal sebagai salah satu laluan kapal yang tersibuk di dunia. Penggunaan laluan tersebut mempunyai kesan positif kepada industri perkapalan, dagangan dan pertumbuhan ekonomi Malaysia. dan Kerajaan perlu memastikan agar kesan sampingan atau negatif yang terhasil dari keadaan ini dapat dikawal dan meninggalkan kesan yang minima kepada negara. Insiden pelanggaran kapal di kawasan perairan marin lazimnya mempunyai implikasi keselamatan dan masalah pencemaran alam sekitar yang serius.

JENIS DAN KATEGORI BUANGAN

2. Pencemaran minyak ke atas alam sekitar marin berlaku kerana pelbagai sebab seperti pelepasan dari punca daratan, pemunggaran kargo minyak di terminal, pelepasan minyak dari operasi kapal, tumpahan minyak akibat pelanggaran kapal dan pelepasan dari aktiviti penggerudian serta pengeluaran petroleum.

3. Buangan atau sisa minyak yang dihasilkan oleh operasi atau perkhidmatan perkapalan mempunyai sifat yang memudaratkan kualiti alam sekitar sekiranya tidak diurus dengan selamat dan berkesan. Dalam konteks kejadian tumpahan minyak, jenis dan kategori sisa minyak yang perlu diurus tidak berbeza dengan pelepasan semasa operasi manakala kuantitinya jauh lebih besar dan ditakrifkan sebagai kejadian kecemasan. Sisa minyak yang dikesan termasuk:

- (i) minyak mentah
- (ii) minyak tertapis
- (iii) stok campuran berminyak
- (iv) minyak enjin; dan
- (v) campuran air-minyak

4 Menerusi langkah kawalan dan tindakan seperti yang digariskan di bawah Rancangan Kontingensi Kebangsaan Kawalan Tumpahan Minyak, ancaman sisa minyak terhadap kawasan perairan dan pantai negara dapat dikurangkan. Walau bagaimanapun, sisa minyak yang terkumpul termasuk di peringkat operasi pembersihan pantai masih perlu diurus dan dihapus secara selamat.

5. Pencemaran minyak mempunyai kesan ketampakan, menjejaskan ekosistem marin dan pantai, mengancam kesihatan dan kemudahan awam serta menyebabkan kehilangan sumber ekonomi. Ciri-ciri minyak yang menyebabkan ianya berbahaya termasuk:

- (i) mengandungi bahan 'carcinogen';

- (ii) kekal di dalam tisu biota marin; dan
- (iii) berkumpul dan meningkat mengikut rantai makanan.

Kajian yang dijalankan telah membuktikan bahaya dan kesan sisa minyak.

DASAR DAN PERUNDANGAN MENGENAI PENGURUSAN SISA MINYAK DARI KAPAL

6. Kawalan ke atas sisa minyak kapal wujud di bawah perundangan kebangsaan dan antarabangsa:

Antarabangsa

- International Convention for the Prevention of Pollution from Ships (MARPOL 73/78)
- International Convention on the Prevention of Marine Pollution of Waste and Other Matter (LONDON CONVENTION 1972)
- International Convention on Oil Pollution Preparedness, Response and Co-operation, 1990
- Basel Convention on the Control of Transboundary Movements of Hazardous Wastes and their Disposal, 1989

Kebangsaan

- Akta Kualiti Alam Sekeliling, 1974
- Ordinan Kapal Saudagar, 1952
- Akta (Langkah Keselamatan) Petroleum, 1984

7. Sisa minyak yang terkumpul semasa operasi pembersihan terbahagi kepada kategori berikut:-

N015	Campuran minyak-air seperti air balast
N016	Enapcemar dari tangki penyimpanan minyak
N231	Tanah-tanah, air, puing atau bahan tercemar hasil daripada proses pembersihan tumpahan bahan kimia atau buangan terjadual

8. Pihak yang bertanggungjawab ke atas pengurusan sisa minyak di atas hendaklah memastikan:-

- (i) sisa distor dengan baik dalam bekas yang kukuh dan dilabel dengan jelas (aspek pemeriksaan dan penyenggaraan hendaklah diambilkira sekiranya tempoh penstoran adalah signifikan);
- (ii) inventori yang betul disediakan;

- (iii) sisa minyak diolah atau dilupus di premis yang ditetapkan sahaja; dan
- (iv) sisa minyak diangkut oleh kontraktor ke premis pengolahan atau pelupusan secara selamat dan teratur (pengisian nota konsainan akan memastikan penerimaan sisa yang sempurna).

KAEDAH PENGOLAHAN DAN PELUPUSAN

9. Pemilihan kaedah pengolahan dan pelupusan bergantung kepada kualiti dan kuantiti sisa minyak serta kewujudan kemudahan berkenaan. Sisa minyak yang terkumpul boleh diolah menggunakan kaedah seperti berikut:-

- (i) pemerolehan kembali;
- (ii) pengolahan atas tanah;
- (iii) penggunaan semula sisa, dan
- (iv) stabilisasi.

Kesemuanya adalah kaedah yang telah sedia diamalkan berdasarkan teknologi yang terbukti berkesan. Di Malaysia, kemudahan pengolahan atas tanah dan kemudahan insinerator sisa minyak dilesen di bawah Akta Kualiti Alam Sekeliling. Selain itu, terdapat juga kemudahan pemerolehan kembali yang mampu menerima sisa minyak untuk tujuan pemprosesan.

PENUTUP

10. Pengurusan sisa minyak yang terhasil dari insiden tumpahan minyak mempunyai opsi yang tidak terhad. Adalah disyorkan agar kemudahan yang mampu menerima sisa minyak dikenalpasti dan terdapat kefahaman berhubung kerjasama dan penglibatan pengendali buangan dengan semua agensi bertanggungjawab dalam keadaan kecemasan seperti kejadian tumpahan minyak. Di samping itu, elemen kos bagi tujuan pelupusan hendaklah diambilkira agar pengurusan sisa minyak dapat dilaksanakan dengan lebih licin.

MARIANA MD. NOR
Bahagian Kawalan
Jabatan Alam Sekitar

Kursus Kawalan Tumpahan Minyak Dan
Pembersihan Pantai

JABATAN ALAM SEKITAR

Kursus Kawalan Tumpahan Minyak Dan Pembersihan Pantai

Pengangkutan, Rawatan Dan Pelupusan
Sisa Minyak

TAFSIRAN

Minyak :

- (a) Minyak mentah, minyak diesel, minyak bahanapi, minyak pelincir
- (b) apa-apa lain jenis minyak yang ditetapkan oleh Menteri

Buangan :

Apa-apa benda yang ditetapkan sebagai buangan, sama ada cecair, pepejal atau gas yang dilepaskan, dikeluarkan atau diletakkan dalam alam sekeliling dengan apa-apa isipadu, perkandungan atau cara hingga menyebabkan perubahan kepada alam sekeliling

JABATAN ALAM SEKITAR OHT 1

Kursus Kawalan Tumpahan Minyak Dan Pembersihan Pantai

Punca-Punca Utama Pencemaran Minyak
Ke Atas Alam Sekitar Marin

- Pelepasan dari punca daratan
- Pelepasan/ Pemandahan minyak di terminal minyak
- Pelepasan dari operasi kapal tangki
- Tumpahan minyak semasa perlanggaran kapal
- Pelepasan dari operasi pengeluar minyak luar pantai

JABATAN ALAM SEKITAR OHT 2

Sisa Minyak Yang Boleh Dikesan

- Minyak mentah
- Minyak tertapis
- Stok campuran berminyak
- Minyak enjin
- Campuran air-minyak



SIFAT BUANGAN MINYAK

- Mengandungi bahan penyebab kanser
- Kekal di dalam tisu biota marin
- Berkumpul dan meningkat mengikut rantai makanan



KAJIAN KE ATAS SPESIS KEPAH DI LONG COVE, 1975

Insiden tumor tertinggi terdapat pada kepah di kawasan yang paling teruk terjejas oleh tumpahan minyak



Tahap "Survival" Ikan Di Dalam Air Laut Yang Dicemari Petroleum Dan Minyak Bunker

Produk Petroleum	Kandungan (ml/l)	Masa Kematian Ikan (Jam)	
		50 %	100 %
Petroleum	0.25	96	140
Minyak Bunker	0.25	32	92
Minyak Bunker	0.1	98	154
Minyak Bunker	0.05	120	190



KAWALAN PERUNDANGAN SEDIA ADA Antarabangsa

- MARPOL 73/78
- LONDON CONVENTION 1972
- International Convention On Oil Pollution Preparedness, Response and Cooperation, 1990
- Basel Convention on Control Of Transboundary Movements Of Hazardous Wastes & Their Disposal 1989



Kebangsaan

- Akta Kualiti Alam Sekeliling 1974
- Ordinan Kapal Saudagar 1952
- Akta (Langkah Keselamatan) Petroleum 1984



KATEGORI BUANGAN DI BAWAH AKAS

- N015 Campuran minyak-air
- N016 Enapcemar dari tangki simpanan minyak
- N231 Tanah-tanah, air, puing dan bahan tercemar hasil daripada proses pembersihan tumpahan kimia atau buangan terjadual



CARTA ALIR PENGENDALIAN BUANGAN MINYAK AKIBAT TUMPAHAN MINYAK



RINGKASAN OBJEKTIF MENGIKUT CARTA ALIR

- Mencegah penyebaran buangan minyak di permukaan air
- Menghadkan penyebaran buangan minyak
- Mengumpul dan mengeluarkan buangan minyak dari permukaan air
- Menstor buangan minyak sebelum dipindahkan
- Memindah buangan minyak untuk perolehan kembali atau pelupusan akhir
- Melupus bahan tercemar/buangan secara selamat dan berkesan



KATEGORI PENSTORAN BUANGAN MINYAK

- Penstoran sementara
- Penstoran lanjutan (extended)
- Penstoran kekal

JENIS PERALATAN PENSTORAN

- Tangki mudahalih
- Dram
- Kapal tangki luar pantai lanjutan
- Terminal minyak [kekal]



KEPERLUAN PENSTORAN

- Inventori buangan
- Berbenteng
- Berbumbung atau bertutup
- Permukaan penstoran yang tidak telus
- Pembungkusan sesuai dan yang kukuh
- Susunatur yang baik
- Penyusunan bekas buangan
- Pemeriksaan buangan yang distort
- Prosedur kecemasan



PEMINDAHAN BUANGAN MINYAK

- Pelupusan akhir lazimnya terletak di kawasan daratan

Kaedah Pemindahan

- Tongkang
- Lori tangki
- Lori hampagas
- Label bahaya
- Maklumat buangan
- Nota kosainan