

**Series of CEMS Guidelines**

**Volume 1 :**

**GUIDELINES FOR THE  
INSTALLATION &  
MAINTENANCE OF  
CONTINUOUS EMISSION  
MONITORING SYSTEMS (CEMS)  
FOR INDUSTRIAL PREMISES/  
FACILITIES**



**DEPARTMENT OF ENVIRONMENT  
MINISTRY OF ENERGY, SCIENCE, TECHNOLOGY, ENVIRONMENT  
AND CLIMATE CHANGE  
LEVEL 1-4, PODIUM 2 & 3  
NO. 25, WISMA SUMBER ASLI, PRECINT 4  
FEDERAL GOVERNMENT ADMINISTRATIVE CENTRE  
62574 PUTRAJAYA  
MALAYSIA**

## Table of Contents

<b>Foreword</b>	i
<b>Acknowledgment</b>	ii
<b>Feedback</b>	ii
<b>Record of Amendments</b>	ii
<b>Abbreviations</b>	iii
<b>Chapter 1 - Introduction</b>	1
1.1 Introduction	1
1.2 Objectives	1
1.3 Definitions	2
<b>Chapter 2 – Applicability</b>	8
2.1 Applicability	8
2.2 Emission Limit Value	9
2.3 Valid Averages	12
2.4 Legal Compliance	12
2.5 Roles and Responsibilities	13
2.6 Process Flow of CEMS	15
<b>Chapter 3 – CEM System</b>	18
3.1 Sampling Systems	18
3.1.1 Extractive	19
3.1.2 In-Situ	20
3.2 Selection of CEM Sampling System	21
3.3 CEMS analyzers	23
3.4 Data Acquisition Handling System (DAHS/DAS)	32
3.5 Data Interface System (CEMS-DIS)	33
<b>Chapter 4 - CEM System Requirements</b>	34
4.1 Design Specifications	34
4.2 Installation Specifications	37
<b>Chapter 5 - Quality Assurance Programs</b>	40
5.1 Quality Assurance Programs	40
5.2 Functional Test	42
5.3 Calibration & Variability Test (QAL2-PAT)	43
5.4 On-Going Performance Monitoring (QAL3-OGPM)	51
5.5 Annual Surveillance Test (AST)	53
<b>Chapter 6 - Reporting</b>	54
6.1 Record Keeping	54
6.2 Reports	54
<b>Reference</b>	

## **Appendix**

Appendix 1	Registration Form For CEMS related Services Providers
Appendix 2	Application of Approval CEMS For Industries
Appendix 3	Functional Test Audit Report
Appendix 4	Calibration & Variability Test / Annual Surveillance Test – Report Format

## **Figures**

Figure 2.1	CEMS installation procedure
Figure 3.1	Example of Extractive CEMS
Figure 3.2	Example of In Situ CEMS
Figure 3.3	Basic Extractive CEM system
Figure 3.4	Typical in-situ and In-situ Point CEM System
Figure 3.5	Summary of the CEM sampling method recognize by DOE
Figure 3.6	CEM system control and DHAS functions
Figure 4.1	Sampling probe location
Figure 4.2	Measurement point for Point CEMS
Figure 4.3	Measurement point for Path CEMS
Figure 5.1	The Sequence of Quality Assurance and Quality Control activities
Figure 5.2	Flow Chart for Calibration & Variability Test of CEMS
Figure 5.3	Reference method traverse points on a measurement line

## **Tables**

Table 2.1	Emission Limit Value for some of the source sectors required CEMS
Table 2.2	Roles and Responsibilities of CEMS
Table 3.1	Comparison of features between extractive and in-situ system
Table 3.2	Typical analytical techniques used in CEM system
Table 3.3	Substance to monitor with applicable monitoring technique
Table 4.1	Requirement on the measurement of uncertainty of CEM system
Table 5.1	Outline for a CEM System Quality Assurance Manual
Table 5.2	The requirements for functional tests
Table 5.3	Situation arise during parallel measurement and procedure to determine calibration function.
Table 5.4	Generating calibration functions for NO <sub>x</sub>
Table 5.5	Related variability test equation and criteria
Table 5.6	Performance Criteria of Gases and Particulate CEMS

# Foreword

This guidelines document are aimed to help industries in proper implementation of online emission monitoring system through proper selection, operation and data transfer in a transparent self-regulatory mechanism. As Continuous Emission Monitoring System (CEMS) installation is required under the Environmental Quality (Clean Air) Regulations 2014 for some specified industries, a comprehensive guidance needs to be provided for the relevant parties; plant operators, CEMS stack tester, equipment suppliers, manufacturers, DOE officer and those who are with interested in continuous emissions monitoring systems (CEMS) implementation in Malaysia.

Information provided comprised of the applicability of CEMS in Malaysia, Technologies of CEMS, CEMS system requirement including design specification and installation, quality assurance and reporting requirement. It is expected all parties in the industry involved in the implementation of CEMS will refer to this document in order to ensure a reliable CEMS operation and meeting CEMS specification specified by the DOE Malaysia.

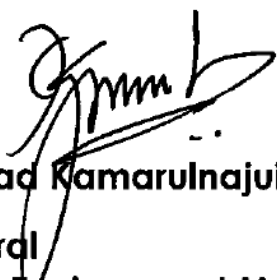

**Dato' Dr. Ahmad Kamarulnajib Bin Che Ibrahim**

**Director General  
Department of Environment Malaysia  
21st June 2019**

# Acknowledgments

This document has been prepared to fulfill Regulation 17 of Clean Air Regulation 2014 (CAR 2014) enforce by Department of Environment Malaysia.

The following DOE staff were centrally involved in the development and review of this document:

1. Mashitah Binti Darus
2. Mohd Hidzir Bin Bakar
3. Nor A'zman Bin Rosli
4. Suhaimi Bin Azmi
5. Dasuki Loo Bin Abdullah
6. Noor Suffianhadi Bin Ramly
7. Hapsah Bin Mohamad
8. Shareena Binti Suffian
9. Farah Diyana Binti Rusli
10. Muhammad Yuzwan Bin Muhammad Yunos
11. Mohamad Lotfee Bin Mohamad Zaid
12. Hairi Bin Nordin

## Feedback

Any comments or suggested improvements to this document should be addressed to Department Of Environment Malaysia, Air Division, Putrajaya. All our supplementary to this guideline can be found at [www.doe.gov.my](http://www.doe.gov.my) and <https://iremote.doe.gov.my>

## Record of Amendments

Version	Date	Amendment
1.0	6 Nov 2009	1 <sup>st</sup> publication guidelines together with Vol 2: Guideline for the Continuous Emission Monitoring System – Data Interface System (CEMS-DIS).
2.0	Mac 2019	A major rewrite incorporating the previously guidelines Vol 1. There are also changes to reflect the gazettelement of Clean Air Regulation 2014.

## List of abbreviations

AST	Annual Surveillance Test
CAR14	Clean Air Regulation 2014
CEMS	Continuous Emission Monitoring System
CO	Carbon Monoxide
CO <sub>2</sub>	Carbon Dioxide
CVT	Calibration & Variability Test
DAS	Data Acquisition System
DIS	Data Interface System
DOAS	Differential optical absorption spectroscopy
DOE	Department Of Environment
ELV	Emission Limit Value
EQA	Environmental Quality Act
FID	Flame Ionization Detector
FTIR	Fourier transform infrared
GFC	Gas filter correlation
HCL	Hydrogen Chloride
HF	Hydrogen Fluoride
IR	Infrared
iREMOTE	Integrated Remote Monitoring Enforcement System
MCERT	Monitoring Certification Scheme
NDIR	Non-dispersive Infrared
NDUV	Non-dispersive Ultraviolet
NMVOC	Non Methane Volatile Organic Compound
NO	Nitrogen Oxide
NO <sub>2</sub>	Nitrogen Dioxide
O <sub>2</sub>	Oxygen
OGPM	On-Going Performance Monitoring
PAS	Photoacoustic Spectroscopy
PM	Particulate Matter
QA	Quality Assurance
QAL	Quality Assurance Level
QAP	Quality Assurance Plan
SO <sub>2</sub>	Sulphur Dioxide
SO <sub>3</sub>	Sulphur Trioxide
SRM	Standard Reference Method
TLD	Tunable Laser Diode
TOC	Total Organic Carbon
TUV	German Technical Inspection and Monitoring Union
VCR	Valid Calibration Range

# Chapter 1 – Introduction

## 1.1 Introduction

- 1.1.1 Continuous Emission Monitoring Systems (CEMS) refers to a packaged of equipment required for determination of emission pollutant (gases, particulates or smoke opacity) which may include sampling system, analyzer or monitor, other auxiliary equipment and integrated with a data acquisition system. The continuous measurement of emission pollutant either gases, particulates or smoke (opacity) emitted from stationery source will provide a continuous record of air pollution control equipment performance and will determine compliance with emission of operation limits.
- 1.1.2 CEMS are required to be installed at certain facilities which are subject under the Environmental Quality (Clean Air) Regulations 2014 (CAR 2014) or at any activities which deem are required to be installed (e.g. EIA projects, problem facilities) by Department of Environment Malaysia (DOE) jurisdiction under Environmental Quality Act (EQA) 1974.
- 1.1.3 For the plant operator, properly installed and operating CEMS can provide information about the operation of key processes and describe the effectiveness of the air pollution control techniques. Having the ability to examine various aspects of the facility's operation can provide the user the opportunity to make critical adjustments for process optimization and cost reduction. Additionally, CEMS can prove to be important documentation of compliance status in this time of heightened public concern about air pollution.
- 1.1.4 For regulatory agencies, the data provided by a CEMS are used to supplement on-site visit, to identify problem sources, and to determine if source emission limits and proper operation and maintenance requirements are being met. With a better picture of actual emissions, the regulator's ability to develop strategies for future program directed at emissions reduction can be enhanced.
- 1.1.5 The main goal of both the plant operators and the regulatory agency is to obtain accurate and reliable information about stack emission as well as to ensure that no air pollution occurs and the environment is constantly preserved.

## 1.2 Objectives

- 1.2.1 This document provides information on
- CEMS equipment and the pollutants that are continuously monitored,
  - the industrial sectors (activities) that are subjected to the CEMS requirements under the CAR 2014;
  - requirement in application of installing CEMS
  - requirement on Quality Assurance (QA) Plan and reporting requirement

### 1.3 Definitions

<b>95% confidence interval</b>	Is a range of values (emission value) that can be 95% certain contains the true mean of the population.
<b>Annual Surveillance Test (AST)</b>	Is to check whether the calibration function determined during the Calibration and Variability Test is still valid. The AST consists of the same functional tests as those used in QAL2-CVT
<b>Audit</b>	An as-found accuracy assessment of CEMS components using an authoritative certified standard.
<b>Calibration error</b>	The difference between the response of the pollutant, diluent to the know value of the appropriate reference material; gas, filter or signal.
<b>Calibration</b>	determination of a calibration function with (time) limited validity applicable to a CEM at a specific measurement site
<b>Calibration function</b>	linear relationship between the values of the SRM and the CEM with the assumption of a constant residual standard deviation  <i>Note:</i> The calibration function describes the statistical relationship between the starting variable (measured signal) of the measuring system and the associated result of measurement (measured value) simultaneously determined at the same point of measurement using a SRM.
<b>CEMS</b>	The total equipment required to sample, condition, analyze and provide a permanent and continuous data record of pollutant concentration. This includes the equipment necessary to perform the required routine calibration, data acquisition and data interface system for the data be able transferred online to DOE
<b>CEMS Audit Tester</b>	Certified stack tester approved and recognized by DOE to perform the SRMs for the Calibration and Variability Test and Annual Surveillance Test procedures
<b>CEMS Manufacturer</b>	Companies that make CEMS products, supplying, achieving and maintaining certification of CEMs to the applicable certification performance standards
<b>CEMS supplier/consultant</b>	Companies that supplying CEMS product, correctly installing, commissioning and maintaining appropriate, certified CEMs to applicable installations. They also responsible to give advice on CEMS requirement and compliance to plant operator. CEMS supplier may are the same as CEM manufacturer
<b>Centroidal area</b>	A concentric area that is geometrically similar to the stack or duct cross section and is no greater than 1 percent of the stack or duct cross-sectional area

<b>Certification range</b>	Range over which the CEM is tested and certified for compliance with the relevant performance criteria <i>Note:</i> Certification range is always related to the daily ELV.
<b>Correlation</b>	Mathematical relationship for correlating the output from your CEMS to a concentration, as determined by the Standard Reference Method. The correlation is expressed in the measurement units that are consistent with the measurement conditions of CEMS.
<b>Cycle Time</b>	The time required to complete one sampling, measurement, and reporting cycle. For a batch sampling PM CEMS, the cycle time would start when sample gas is first extracted from the stack/duct and end when the measurement of that batch sample is complete and a new result for that batch sample is produced on the data recorder.
<b>Data Acquisition System</b>	The component of the CEMS designed to interpret and convert individual output signals from pollutant concentration monitors, flow monitors, diluent gas monitors and other components of the monitoring system to produce a permanent continuous record of the measurement and desired parameters
<b>Diluent Gas</b>	A major gaseous constituent in a gaseous pollutant mixture. For combustion sources, CO <sub>2</sub> and O <sub>2</sub> are the major gaseous constituents of interest. Schedule 2 and 3 of Clean Air Regulation 2014 specified reference gas applicable for different type of activities/facilities.
<b>Downstream</b>	The direction of travel from a source to an outlet.
<b>Downtime</b>	Time periods of source operation in which invalid CEMS data or no data is collected due to any appropriate reason. This includes periods of documented QA activities, calibration, preventive maintenance, malfunction, audits which results in periods of invalid data and 'out-of-control' periods.
<b>Emission Limit Value (ELV)</b>	Limit values given by DOE in CAR 2014 or from DOE directives, notices, licenses, or approval under EQA 1974. ELV can be stated as concentration limits expressed as half-hourly average, and daily average. For compliance no daily average exceeds ELV, and no half hour average exceeds 2 times ELV
<b>Excess Emission</b>	For CEMS, it is an exceedance of the applicable emission limit value (ELV) as indicated by valid measurement of the monitor and reported using the appropriate significant digits, units and averaging period that directly corresponds to the applicable emission limit.
<b>Extractive Monitoring System</b>	A system that withdraws gas sample from the stack and transports the sample to the analyzer.

<b>Functional Test</b>	The functional tests are a series of checks carried out on the CEMS and must be performed before Calibration and Variability Test and Annual Surveillance Test
<b>Hydraulic Diameter</b>	<p>Calculated value used to determine the upstream and downstream distances for locating flow to pollutant concentration monitors in flues, ducts or stacks with rectangular cross-sections.</p> <p>The characteristic dimension of a duct cross section is defined by:</p> $D_h = \frac{4 \times \text{area of sampling plane}}{\text{Perimeter of sampling plane}}$
<b>Industrial Premises / Facility</b>	Any applicable stationary air contaminant emission source (institutional, commercial, industrial structure, installation, plant, source or building) required by the DOE to operate a CEMS.
<b>In-Situ Monitor</b>	CEMS design that measures source-level gas emissions directly inside a stack or duct at actual conditions. For pollutant or combustion gas measurements, the source emission gas is not conditioned, so it is considered a 'wet' measurement.
<b>Inspection</b>	A check for the conditions that is likely to affect the reliability of the system. E.g. of these conditions would include the following: damage to system components, leaks, a low flow condition in sample transport system, alarms, adequate supply of consumables, etc.
<b>Internal Diameter</b>	The inside diameter of stack/duct
<b>Leak checks</b>	A test to determine any leakage on entire CEMS sampling system.
<b>Linearity Test</b>	Systematic deviation, within the range of application, between the accepted value of a reference material applied to the measuring system and the corresponding result of measurement produced by the calibrated measuring system
<b>Maintenance interval</b>	Maximum admissible interval of time for which the performance characteristics remain within a pre-defined range without external servicing, for example refill, calibration, adjustment
<b>Malfunction</b>	Any sudden, infrequent and not reasonably preventable failure of any part of the CEMS that are caused by the equipment to function outside established design and/or performance specifications. Failures that caused in part by poor maintenance or careless operations, in the opinion of DOE, are not considered malfunction.
<b>Measured signal</b>	Output from a CEM in analogue or digital form which is converted into the measured value with the aid of the calibration function

<b>Measurement Range</b>	The set of values that the CEM can measure, from the lower detection limit (i.e. near zero) to a set upper limit
<b>Normal load</b>	Most frequently used load level over the past four (4) representative operating quarters. For new unit/facility or if no historical load data are available, designate the normal load based on the expected or projected manner of operating the unit. The unit shall be expressed either in unit megawatt (electrical output), lb/hr of steam load or mmBtu/hr (thermal output), or in cfm or m <sup>3</sup> /hr of air flow rate (not produce electrical or thermal output)
<b>On-going Performing Monitoring (QAL3-OGPM)</b>	Procedure ensures that the CEM remains within the required specifications during continued use. It achieves by requiring the plant operator's personnel (competence person) regularly measure the drift and precision on the maintenance interval of the CEM
<b>Output CEMS</b>	Reading, or digital or analogue electrical signal generated by a CEM in response to a emission substance
<b>Paired measurement</b>	Simultaneous recording of results of measurement at the same measurement point using two CEMs of identical design
<b>Path CEMS</b>	CEMS that measures the gas concentration along a path greater than 10 percent of the equivalent diameter of the stack or duct cross section.
<b>Calibration and Variability Test (QAL2-CVT)</b>	Consists of a set of functional tests to check that the CEMs are operating in a satisfactory manner and a set of standard reference method (SRM) repetitions as a means of verifying the performance of the CEMs, and calibrating them if necessary, by applying a calibration function.
<b>Plant operator</b>	An industry company who responsible on management and operation of their facility, and required to install, operate and maintain CEMS
<b>Point CEMS</b>	CEMS that measures the gas concentration either at a single point or along a path equal to or less than 10 percent of the equivalent diameter of the stack or duct cross section.
<b>Quality Assurance</b>	An integrated system of management activities involving planning, implementation, assessment, reporting and quality improvement to ensure that a process, item or service is of the type and quality needed and expected by the end users.
<b>Quality Assurance Plan (QAP)</b>	A formal document describing in comprehensive detail the necessary quality assurance procedures, quality control activities and other technical activities that need to be implemented to ensure that the results of the work performed will satisfy the stated performance or accepted criteria.

<b>Quality Control</b>	The overall system of technical activities that measure the attributes and performance of a process, item or service against defined standards to verify that they meet the specifications established by the customer, operational techniques and activities that are used to fulfill the need for quality.
<b>Reference material</b>	substance or mixture of substances, with a known composition within specified limits
<b>Reference Method Sampling Location</b>	the location in source's exhaust stack/duct to collect manual standard reference method data to assess CEMS
<b>Response Time</b>	the time interval between the start of a step change in the system input and the time when the pollutant monitor output reaches 90 percent of the final value
<b>Source Shutdown</b>	The cessation of operation of an emission source for any purpose.
<b>Source Start Up</b>	The starting in operation of an emission source for any purpose.
<b>Span drift</b>	change in CEM reading at the span point over the maintenance interval
<b>Span Level/Value</b>	A design value that represents an estimate of the highest expected value for a parameter, based on the applicable emission limit. Span is calculated as a percentage range of the emission limit.
<b>Standard Condition</b>	A temperature of 273.15°K and an atmospheric pressure of 101.3 kPa.
<b>Standard Reference Methods (SRM)</b>	any approved method of sampling and analysis of pollutant as authorized by the DOE General Director as mention in Regulation 23, CAR 2014.
<b>Supplementary Range</b>	Additional range certified after certification range
<b>Uncertainty</b>	parameter associated with the result of a measurement, that characterises the dispersion of the values that could reasonably be attributed to the measurand
<b>Upstream</b>	the direction of travel from an outlet to a source
<b>Valid Calibration Range</b>	Acceptable region between the limits within which a quantity is measured, received or transmitted, expressed by stating the lower and upper range values.
<b>Valid Data</b>	Any representative data average that meets the validation criteria
<b>Zero &amp; Span Check</b>	A task/test to determine the zero level value and upper/span limit value

**Zero gas**

Gas mixture used to establish the zero point of a calibration curve when used with a given analytical procedure within a given calibration range

**Zero Point**

Specified value of the output quantity (measured signal) of the measuring CEM and which, in the absence of the emission substance, represents the zero crossing of the CEM characteristic

# Chapter 2 – Applicability

## 2.1 Applicability

- 2.2.1 This guideline is applicable to any industrial premise / facility that is required by regulation, permit, agreement or order to install, operate and maintain a CEMS for the purpose of continuously determining and reporting compliance with applicable emission limits or operating permits.
- 2.2.2 Under Regulation 17, CAR 2014 each industrial premise/ facility shall carry out continuous emission monitoring as in addition to the periodic monitoring mentioned in Regulation 16 and as specified in the Second and Third Schedule of CAR 2014; and the measuring devices installed for the purpose of continuous emission monitoring must be complied with the specifications as determined by the Director General.

## 2.2 Emission Limit Value

- 2.2.1 Emission Limit Value (or emission standard) for stationary sources are as prescribed in the EQA 1974 under the CAR 2014 and its subsequent revisions.
- 2.2.2 These regulations and subsequent revisions as mentioned in Second Schedule and Third Schedule of CAR 2014 specify activities and pollutants that are to be monitored continuously and their limit values which are:
- a) Control of fuel burning equipment, incinerator and crematorium; dust load (PM) >2.5 kg/hr;
  - b) Heat and Power Generation;
  - c) Production and processing of ferrous metals (iron & steel mills);
  - d) Production and processing of non-ferrous metals with a capacity  $\geq 0.5$  tons per day for lead or cadmium or  $\geq 2$  tons per day for other metals;
  - e) Oil and gas industries: Refineries (all sizes); Natural gas processing and storage, storage and handling of petroleum products;
  - f) Non-metallic (mineral) industry: Cement production (all sizes); Manufacture of glass including glass fibre with a melting capacity  $\geq 1$  ton of product per day; Manufacture of ceramic products by firing, in particular roofing tiles, bricks, refractory bricks, tiles, stoneware or porcelain with a production capacity  $\geq 10$  tons of product per day.
  - g) Waste Incinerators in all sizes
- 2.2.3 The segmented parameters for the above source activities required CEMS are as outlined briefly in **Table 2.1**.

**Table 2.1: Emission Limit Value for some of the source sectors required CEMS**

Source Activity	Source /Capacity/ Fuel Type	Gas Reference Content	Pollutants	Limit Value (mg/m <sup>3</sup> )
Fuel Burning Equipment	Solid	CO <sub>2</sub> : 12%	Total PM where dust load emitted ≥ 2.5kg/h Opacity	150  20 %
Heat and Power Generation	Boilers > 10MW <sub>e</sub> (Liquid and Solid Fuel)	O <sub>2</sub> : 6% - solid fuel  O <sub>2</sub> : 3% - other fuels	SO <sub>2</sub> NO <sub>2</sub> CO Total PM	500 500 200 50
	Boilers > 10MW <sub>e</sub> (Gas Fuel)	O <sub>2</sub> : 6% - solid fuel  O <sub>2</sub> : 3% - other fuel	NO <sub>2</sub> CO	350 50
	Combustion Turbines > 10MW <sub>e</sub> (Gas Fuel)	O <sub>2</sub> : 15%	NO <sub>2</sub> CO	150 100
	Combustion Turbines > 10MW <sub>e</sub> (Liquid Fuel)	O <sub>2</sub> : 15%	NO <sub>2</sub> CO	200 100
Production and Processing of Ferrous Metals (Iron and Steel Mills)	Sinter plants (waste gas from the sintering belt)	-	SO <sub>2</sub> NO <sub>2</sub> Total PM	500 400 50
	Coke ovens	O <sub>2</sub> : 5%	Total PM	10
	Blast furnace (Regenerator)	O <sub>2</sub> : 3%	Total PM	50
	Basic oxygen furnace (converter gas )	-	Total PM	50
	Electric arc furnaces	-	Total PM	50

Source Activity	Source /Capacity/ Fuel Type	Gas Reference Content	Pollutants	Limit Value (mg/m <sup>3</sup> )
Production and processing of non-ferrous metals with a capacity > 0.5 tons per day for lead or cadmium or > 2 tons per day for other metals	Sinter plants (waste gas from the sintering belt)	-	SO <sub>2</sub> NO <sub>2</sub> Total PM	500 400 50
	Production of copper and zinc		Total PM	20
	Production of lead		Total PM	10
	Primary aluminium		SO <sub>2</sub> Total PM	100 10
	Secondary aluminium		Total PM	10
	Smelting, alloying and refining of aluminium		Total PM	10
	Smelting, alloying and refining of other non-ferrous metals		Total PM	5
Oil and gas industries: Refineries (all sizes); Natural gas processing and storage; storage and handling of petroleum products	Catalytic cracking	-	Total PM SO <sub>2</sub>	40 1200
	Calcination		Total PM	40

Source Activity	Source /Capacity/ Fuel Type	Gas Reference Content	Pollutants	Limit Value (mg/m <sup>3</sup> )
Non-metallic (mineral) industry  Cement production (all sizes)  Manufacture of glass including glassfibre with a melting capacity $\geq$ 1 ton of product per day;  Manufacture of ceramic products by firing, roofing tiles, bricks, refractory bricks, tiles, ceramic glass, stoneware or porcelain, with a production capacity $\geq$ 10 tons of product per day	Cement kiln	O <sub>2</sub> : 10%	NO <sub>2</sub> Total PM	800 50
	Glass furnaces	O <sub>2</sub> for:  Flame heated glass melting furnaces - 8%	SO <sub>2</sub> NO <sub>2</sub> Total PM	800 800 50
	Rotary furnaces for the manufacture of hard quicklime or sintering dolomite	Flame heated pot furnaces and day tanks furnaces - 13%	NO <sub>2</sub> Total PM	1500 50
	Ceramic furnaces	O <sub>2</sub> : 17%	Total PM; where dust load emitted $\geq$ 2.0kg/jam	50

Source Activity	Source/Capacity/ Fuel Type	Gas Reference Content	Pollutants	Limit Value (mg/m <sup>3</sup> )
Waste incinerator		O <sub>2</sub> : 11%	Total PM NMVOC as Total C HCl HF SO <sub>2</sub> NO <sub>2</sub> CO	100 10 40 1 50 200 50

Note :

- a) Emission shall be calculated in term of mass of pollutant per volume of the waste gases (expressed as mg/m<sup>3</sup>) at STP (273K, 101.3 kPA)
- b) Averaging time for continuous monitoring is 30 minutes

## 2.3 Valid Averages

- 2.3.1 The sub average period for determining half-hour average is 1-minute average. A valid half-hour average must contain at least 22 sub average data within half-hour period (75%).
- 2.3.2 A valid 1-minute average must contain valid data readings representing any 45 seconds over the previous 1-minute period.

## 2.4 Legal Compliance

- 2.4.1 For continuous emission monitoring, the limit values are complied with if the evaluation of the results for the operating period within any one calendar year shows that no daily average exceeds the emission limit value, and no half hour average exceeds the two (2) times emission limit value. (Reg. 17(3) CAR 2014).
- 2.4.2 The owner or occupier of the premises shall make evaluations of the continuous emission monitoring in a calendar year, whereby for each calendar day the daily mean value that relates to the daily operating time shall be derived from the half hourly mean values. (Reg. 17(4) CAR 2014).
- 2.4.3 The owner or occupier of the premises shall submit to the DOE the results of evaluations within three (3) months after the end of each calendar year, and such evaluation results are to be kept and maintained by the owner or occupier for at least 3 years. (Reg. 17(5) CAR 2014).
- 2.4.4 In the event where emission limit value standards exceed the prescribed limit values, the owner or occupier of premises shall notify the DOE within 24 hours from the discovery of the excess emission. (Reg. 17(6) CAR 2014).

2.4.5 In the event a monitoring device fails to operate, the owner or occupier of premises shall notify the DOE not later than one hour from the occurrence of such failure. (Reg. 17(7) CAR 2014).

## 2.5 Roles and Responsibilities

2.5.1 CEMS manufacture shall ensure CEM equipment supply to suppliers and plant operator are certified before planning to install

2.5.2 Installation of CEMS at industrial premise/facility requires application to DOE by plant operator beforehand and must be installed by a registered CEMS consultant (which is CEMS suppliers) as listed in DOE website.

2.5.3 To verify that the CEMS has been installed correctly, verified and calibrated, CEMS tester are required to conduct performance audit of CEM after installation and also conducting in regularly basis based on DOE requirement on this guideline.

2.5.4 **Table 2.2** listed the roles and responsibilities of CEMS manufacturers, suppliers, tester, plant operators and DOE (regulator)

**Table 2.2 – Roles and Responsibilities of CEMS**

Roles	Responsibilities	Further Information
CEMS manufacturers	<ul style="list-style-type: none"> <li>Achieving and maintaining certification of CEMS to the applicable performance standards</li> <li>Appoint local CEMS supplier to supply and install CEMS at plant operator's facility</li> </ul>	<ul style="list-style-type: none"> <li>Certified CEMS requirement by DOE are discuss in sub Chapter 4.1</li> <li>Note: CEMS manufacturer and supplier may same</li> </ul>
CEMS suppliers	<ul style="list-style-type: none"> <li>to be as CEMS Consultant to give advice on CEMS requirement and compliance to plant operator</li> <li>supplying ,correctly installing, commissioning of CEMS at plant operator's facility</li> <li>Installing CEMs in a manner which assures their integrity and correct operation to the required performance</li> </ul>	<ul style="list-style-type: none"> <li>Shall ensure the CEMS design requirement (sub Chapter 4.2) and installation requirement (sub Chapter 4.3) are follow</li> </ul>

Roles	Responsibilities	Further Information
	<p>standards</p> <ul style="list-style-type: none"> <li>• When appropriate, cooperating with plant operators and CEMS tester to perform the functional test of CEMS</li> <li>• To ensure CEMS-DIS installed are follow the requirement and CEMS data will transfer online to DOE without interruption</li> <li>• Register as CEMS Consultant and certified CEM equipment with DOE</li> </ul>	<ul style="list-style-type: none"> <li>• refer Guidelines Volume II: Guideline for the Continuous Emission Monitoring System - Data Interface System (CEMS-DIS) for Industrial premises / Facilities</li> <li>• registration as CEMS Consultant and CEMS equipmen through I-Remote (<a href="https://iremote.doe.gov.my/">https://iremote.doe.gov.my/</a>)</li> </ul>
CEMS tester	<ul style="list-style-type: none"> <li>• Register as CEMS audit tester with DOE</li> <li>• Performing the SRM for the QAL 2 and AST procedures</li> <li>• Reporting the results of the QAL 2 and AST to plant operator and DOE</li> <li>• When appropriate, co-operating with plant operator and CEMS supplier to conduct functional test</li> <li>• Notifying the plant operator on the responsibility to ensure the functional test are performed before each QAL 2 and AST.</li> </ul>	<ul style="list-style-type: none"> <li>• registration as CEMS audit tester through I-Remote (<a href="https://iremote.doe.gov.my/">https://iremote.doe.gov.my/</a>)</li> <li>• Refer to Chapter 5 – Quality Assurance Program. All the test required are discuss in this Chapter 5.</li> <li>• Refer to Chapter 6- Reporting</li> </ul>
Plant operator	<ul style="list-style-type: none"> <li>• Register as CEMS Industry with DOE</li> <li>• Monitor continuously emission and comply to CAR14</li> </ul>	<ul style="list-style-type: none"> <li>• registration as Industry through I-Remote (<a href="https://iremote.doe.gov.my/">https://iremote.doe.gov.my/</a>)</li> <li>• Emission complies to CAR14 as mention in Table 2.1 and refer</li> </ul>

Roles	Responsibilities	Further Information
	<ul style="list-style-type: none"> <li>Report to DOE, In the event where emission limit value exceed or CEMS fails to operate</li> <li>Performing QAL3 procedures</li> <li>Ensuring that the functional tests are performed before each QAL 2 and AST</li> <li>Submission of QAL2, QAL 3 and AST reports to DOE</li> </ul>	<p>to sub Chapter 2.3 and 2.4 for CEMS legal compliance requirement.</p> <ul style="list-style-type: none"> <li>Refer to Chapter 6- Reporting</li> <li>Appoint CEMS audit tester approved by DOE.</li> </ul>
DOE	<ul style="list-style-type: none"> <li>as the Regulator, DOE specifying requirement of CEM</li> <li>Registered CEM supplier (consultant), CEMS audit tester and plant operator (industry)</li> <li>Assessing plant operator compliance</li> <li>Assessing CEMS audit tester for compliance</li> <li>Providing guidance</li> <li>Recognising the competence of those plant operator personnel carrying out functional testing</li> </ul>	<ul style="list-style-type: none"> <li>DOE monitor through I-Remote (<a href="https://iremote.doe.gov.my/">https://iremote.doe.gov.my/</a>)</li> </ul>

## 2.6 Process Flow of CEMS

2.6.1 The process of installing and operating CEMS at plant operator's facility begin with registering CEMS consultant (supplier).

2.6.2 The purpose of this registration CEMS consultant is to identify companies specializing in providing the following services: -

- a) Installation and maintenance of Continuous Emission Monitoring System (CEMS) and CEMS Data Acquisition System (CEMS-DAS) at industrial premises; and/or
  - b) Installation and maintenance of CEMS Data Interfacing System (CEMS-DIS) at industrial premises for data transmission from CEMS-DAS to DOE CEMS Remote Monitoring and Enforcement System.
- 2.6.3 CEMS consultant is required to provide information about CEMS equipment to the DOE in order to get registered. Only CEMS equipment which meet the preset condition (detail discuss in Sub Chapter 4.1) in this guideline will be registered under CEMS consultant. The information required as mentioned in **Appendix 1**.
- 2.6.4 All industrial premises / facility (plant operator) which required to install CEMS required to provide information to the DOE of the detail of installation and operational of CEMS. The requirement of CEM system install is elaborate in Chapter 4 of this guideline. The information required as mentioned in **Appendix 2**.
- 2.6.5 Any installation of CEMS approved by DOE required conducting initial test of Calibration and Variability Test of CEMS installed by CEMS Audit Tester. The detail of Calibration and Variability Test required will elaborate in Chapter 5 of this guideline.
- 2.6.6 The process of CEMS data connection from premise to DOE server will need to be executed by CEMS supplier after successfully completion of Calibration and Variability Test by referring to Guidelines Volume II: Guideline for the Continuous Emission Monitoring System-Data Interface System (CEMS-DIS) for Industrial premises/ Facilities
- 2.6.7 For CEMS continuing operation, Quality Assurance Plan (QAP) as approved by DOE must be implemented by plant operator. QAP activities include CEMS operational and maintenance, performance audit, training and monitoring plan. All industrial premises / facility subject to CEMS requirements shall notify the DOE as soon as possible if any changes are made to any part of a CEM system, including its Quality Assurance Program. These QA will be detail explained on Chapter 5
- 2.6.8 **Figure 2.1** summarize the CEMS process flow as mention in para 2.5.1 to 2.5.7.

**Figure 2.1: CEMS installation procedure**

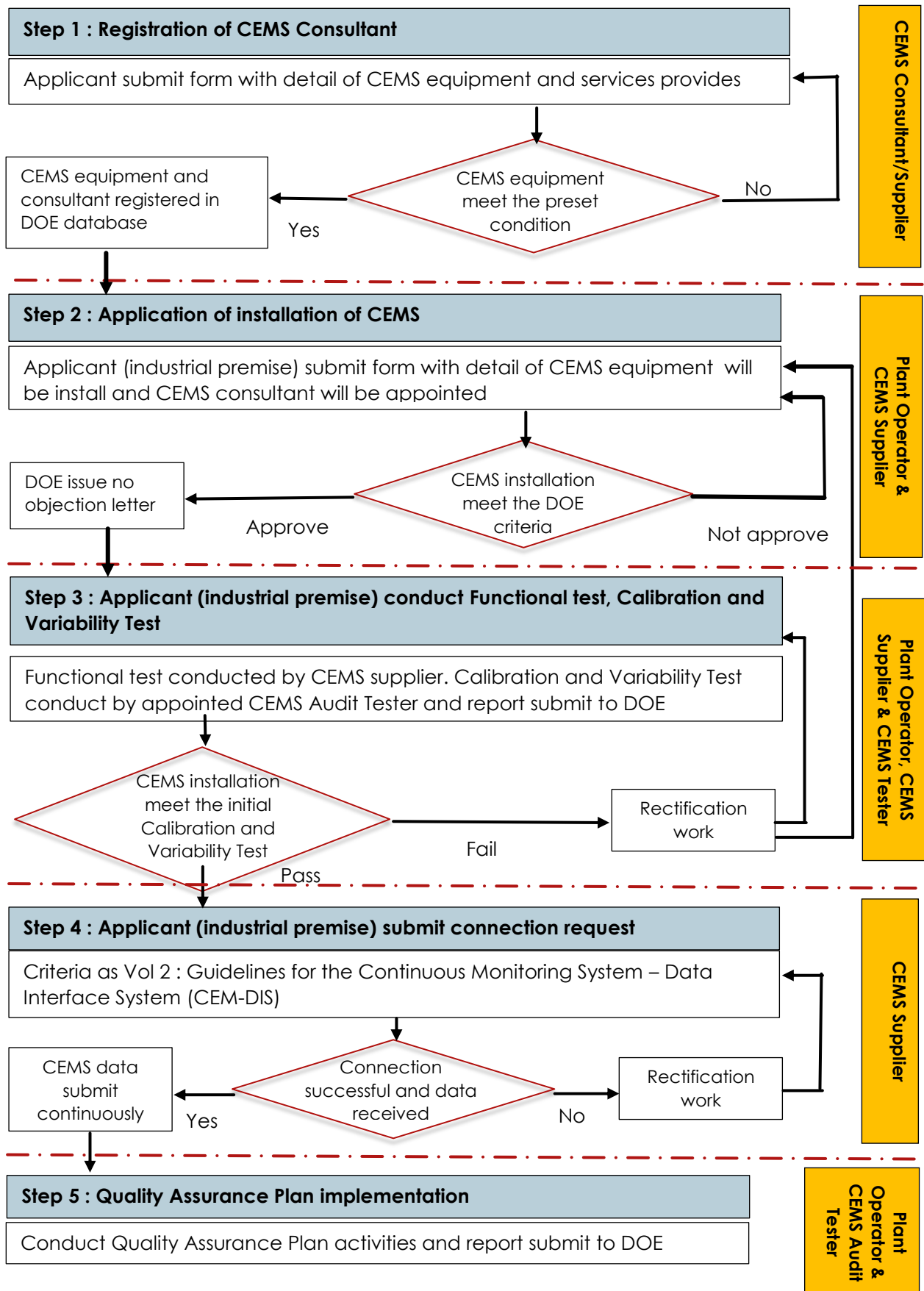

# Chapter 3 – CEM System

A continuous emission monitoring systems (CEMS) is an integrated system that demonstrates source compliance by collecting samples directly from the duct or stack discharging pollutants to the atmosphere. A CEM system consists of all the equipment necessary for the determination of a gas or particulate matter concentration or emission rate. This includes three (3) basic components:

- a. The sampling and conditioning system
- b. The gas analyzers and/or monitor; and
- c. Data acquisition & handling system (DAS/DHAS) and controller system

This chapter will explain more about the CEM component described above.

## 3.1 Sampling Systems

CEM system can be divided into two (2) major categories based on sampling method which is extractive and in-situ. Extractive CEMS capture a sample from the duct or stack, condition the sample by removing impurities and water, and transport the sample to the analyzer in a remote, environmentally protected area (Figure 3.1). In-situ CEMS typically have monitors and/or analyzers located directly in the stack or duct (Figure 3.2).

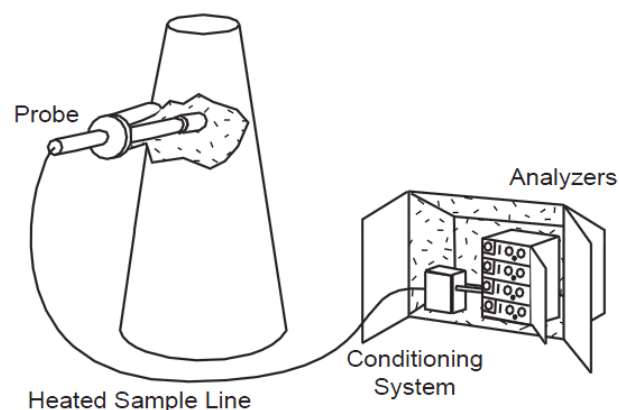

**Figure 3.1 Example of Extractive CEMS** (source : USEPA<sup>1</sup>)

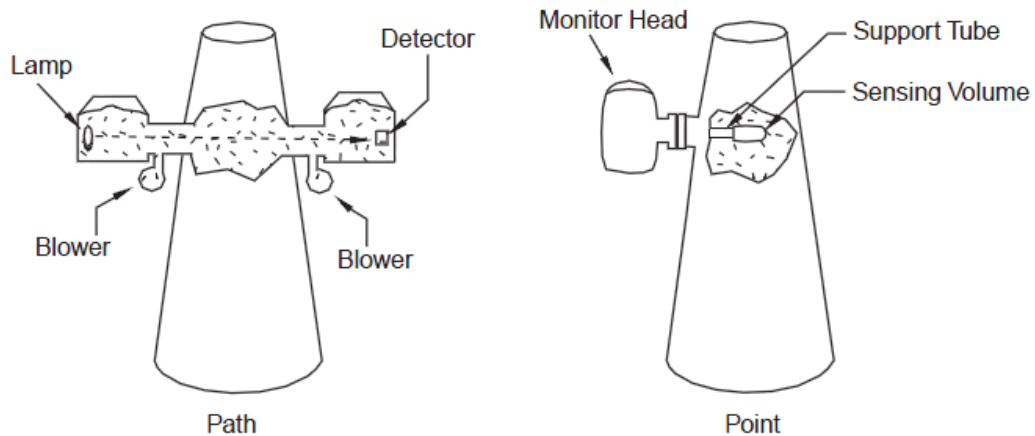

**Figure 3.2 Example of In Situ CEMS** (source : USEPA<sup>1</sup>)

### 3.1.1 Extractive

3.1.1.1 Extractive CEMs comprise the analyser(s) and additional devices (such as conditioning system) for obtaining a measurement result.

3.1.1.2 There are several types of extractive sampling system:

- a) Simple heated lines coupled to heated analysers that measure gases in a hot, wet form.
- b) Heated lines and chiller-driers, delivering the sampled gases to the analyser in cooled, dry form.
- c) Heated lines and permeation-driers, delivering the sampled gases to the analyser in cooled, dry form.
- d) Dilution systems, although these are rarely and not recommend to use in Malaysia.
- e) The stack-mounted probe is coupled directly to a permeation drier, which then passes the cooled, dry sample gas via an unheated line to an analyzer.
- f) There may be NO<sub>x</sub> converters to convert NO<sub>2</sub> to NO in cases where the operator needs to monitor total NO<sub>x</sub> using an analyser which measures NO alone.

3.1.1.2 There are also many variations of these basic forms and as analysers are typically designed for use with specific types of sampling system. Certified CEMS analyser will also state and certified the type of sampling system.

3.1.1.3 Depending on the type of system, extractive CEMS sampling system, conditioning equipment can include sampling probe/port, sampling transfer line, line heaters, calibration gases, a pump, a filter, a condenser or dryer or chillers. **Figure 3.3** show basic extractive CEM system.

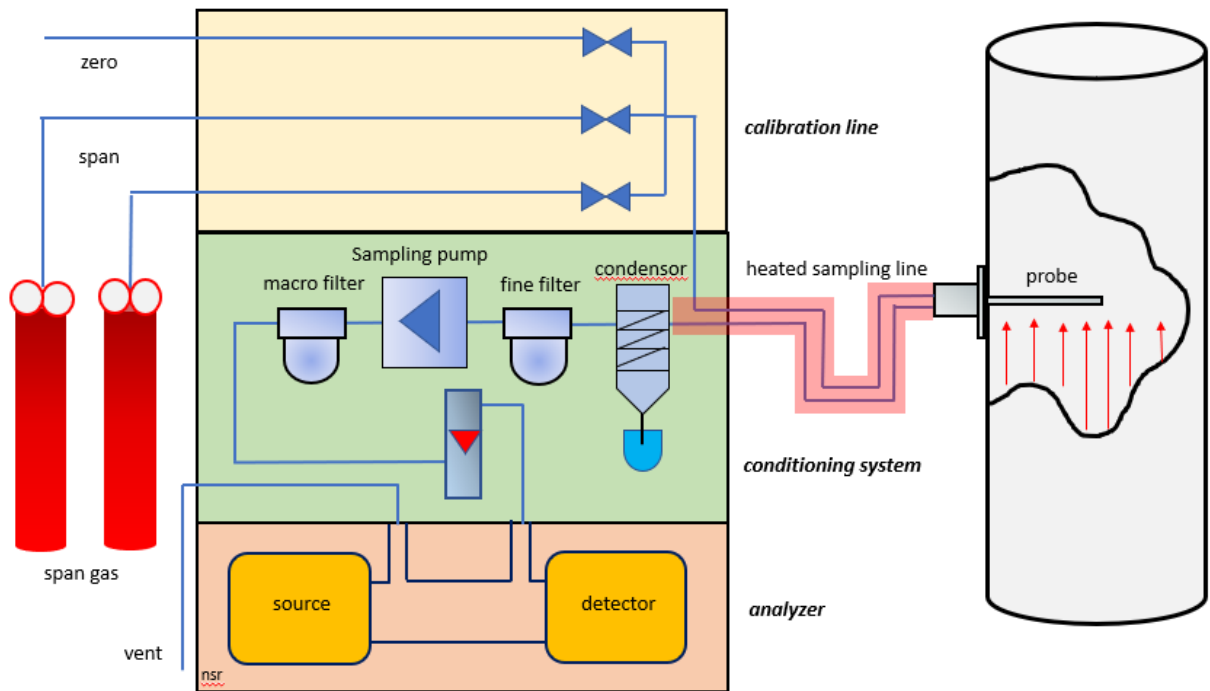

**Figure 3.3: Basic Extractive CEM system**

### 3.1.2 In-Situ

3.1.2.1 In-situ CEMS are systems where the analyzer is physically located in the stack or duct. The pollutant is measured in-situ as it flows through a sampling location placed in the stack or duct. Two (2) types of in-situ measurements:

- a) Point (in stack) – measurement take place at the single point in the stack, as do simple extractive system probes.
- b) Path (cross stack) – measurement are taken across a given path in the emission stream. In-situ path measurement is taken by transmitter sending a signal across the stack and reflecting it back to a detector near the source of signal. Even there is two (2) basic types of in-situ path which is single pass and double pass, only double pass in-situ path CEMS are accepted by DOE

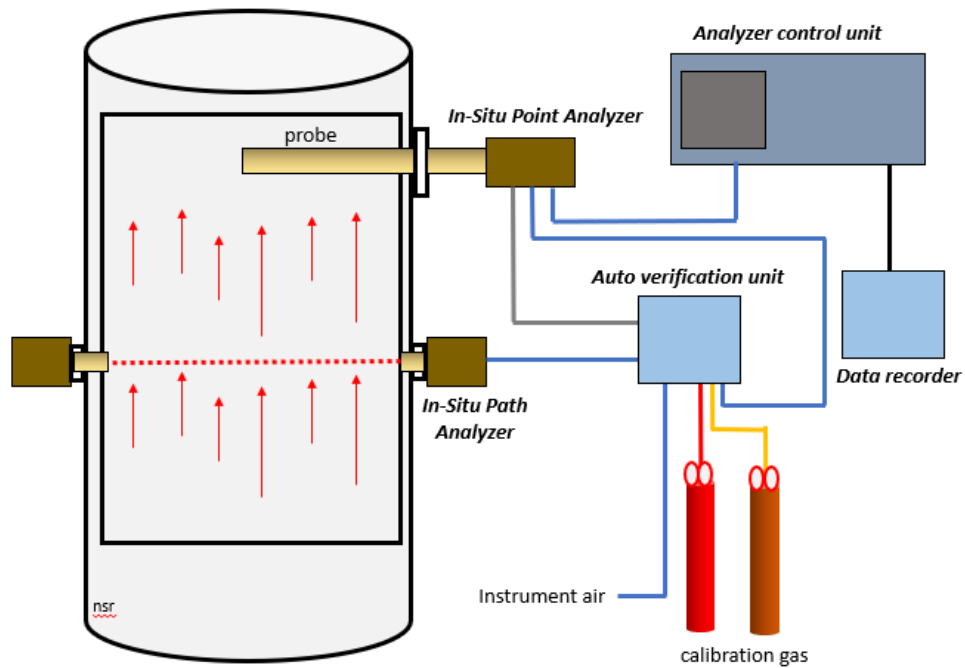

Figure 3.4 - Typical In-situ and In-situ Point CEM System

### 3.2 Selection of CEM Sampling System

3.2.1 **Figure 3.5** summarizes the CEM sampling system. Applicant should justify to DOE which are the best or suitable CEM sampling systems to be install, operate and maintain based on their application. **Table 3.1** summarizes the comparison of features between extractive and in-situ system.

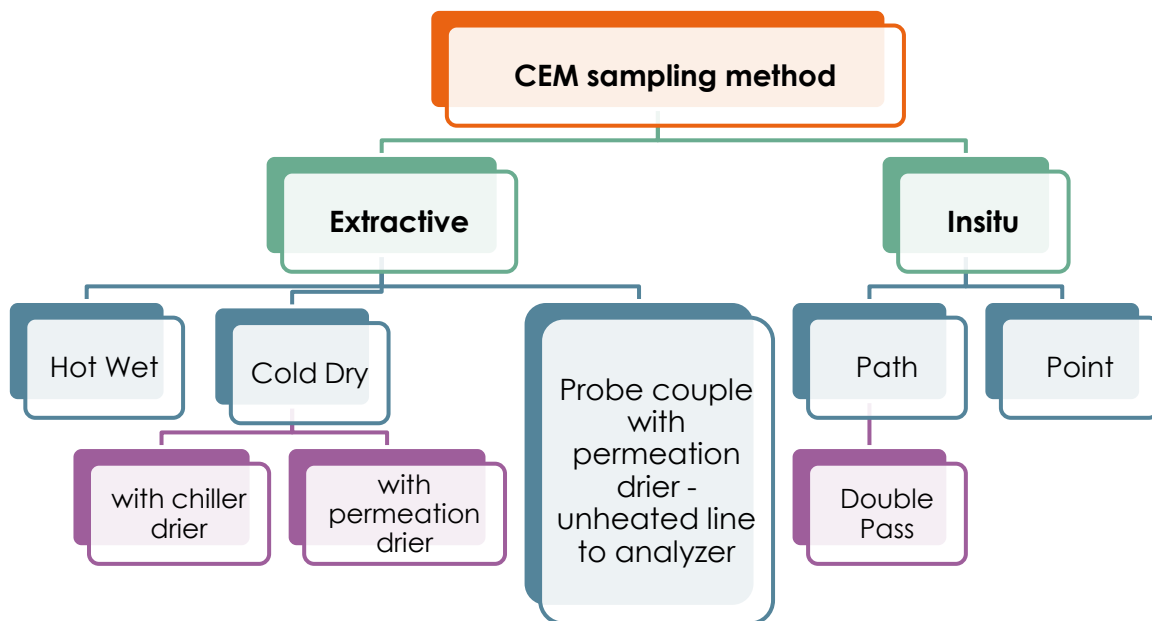

Figure 3.5 - Summary of the CEM sampling method recognized by DOE

Features of Extractive System	Features of In-situ System	
	Path	Point
Can sample from point of average concentration	Linearly average concentration	Can sample from point of average concentration
Can time-shares analyzer	Cannot time shares analyzer	
Analyzer readily located in environmentally controlled shelter, rooms	Analyzer subject to ambient environmentally conditions	
Have large number of maintainable system components	Have fewer number of maintainable system components	
System components may be relatively easy to repair (eg: pump, valve)	System components may be relatively difficult to repair (e.g.: optics, electronic)	
Use cylinder gas for calibration	May use internal gas cell or internal calibration filter for calibration	
Can easily audit with cylinder gas	Cylinder gas audit may require special attachment	Can easily audit with cylinder gas
Do not require temperature compensation	Require temperature compensation	
Sample gas filtered, conditioned to standard, temperature, pressure	High stack temperature, high particulate matter, sticky particulate matter may affect performance	
May alter sample if any extractive component failure	Do not alter sample	
Response time dependent on sample line length	Response time dependent on analyzer response, not sampling	
System problems readily solved on site	System probe may be difficult to solve on site (eg: electro optical problems at stack height)	
Maintenance may not require special training	Maintenance may require higher levels of training	
Inspection maintenance required 2-3 times per week, minimum (depending on maintenance interval specified)	Inspection/maintenance less than those required for extractive systems	

**Table 3.1 - Comparison of features between extractive and in-situ system** (James A Jahnke)

### 3.3 CEMS analyzers

3.3.1 The heart of any CEM system either extractive or in-situ are analyzer. The analyzers will perform the job of measurement of pollutant through the monitoring technique. The monitoring techniques vary from chemical methods using simple electrochemical cells to advanced electro-optical techniques such as Fourier transform infrared spectroscopy.

3.3.2 **Table 3.2** gives summary of the typical monitoring techniques that are used in CEM system. Typically, the facility operator aware of what pollutant requires sampling, but will need guidance on the monitoring technique and analyzer to use. **Table 3.3** has been structured to enable the facility operator or CEM supplier to determine an appropriate monitoring technique

3.3.3 For facility that emit particulate matter, selection of CEM analyser must take consideration of what type air pollution control system install at facility.

3.3.4 The selection of CEM system analyzer must consider both regulatory specifications and performance characteristics.

	Monitoring technique	Sampling Type	Pollutant measured	Note
1	<b>Absorption Spectroscopy - Infrared (IR) or Ultraviolet (UV)</b>			
	i. Nondispersive Infrared (NDIR)	Extractive	CO, CO <sub>2</sub> , SO <sub>2</sub> , NO <sub>x</sub> , etc.	-Multiple gases can be monitored generally no more than 2-5
	ii. Nondispersive Ultraviolet (NDUV) – Differential Absorption	Extractive	SO <sub>2</sub> , NO <sub>2</sub> , NH <sub>3</sub> , Cl <sub>2</sub> etc.	-Multiple gases can be monitored generally no more than 2-5
	iii. Differential optical absorption spectroscopy (DOAS)	In-situ	CO, CO <sub>2</sub> , SO <sub>2</sub> , HCl, HF, NO, NO <sub>2</sub> , NH <sub>3</sub> , VOCs, H <sub>2</sub> O	Multiple gases can be monitored, typically 5+ NO <sub>2</sub> measured directly. Additional gases can be added at relatively low cost.
	iv. IR Gas filter correlation (GFC)	Extractive / In-situ	CO, CO <sub>2</sub> , NO <sub>x</sub> , SO <sub>2</sub> , N <sub>2</sub> O	-Multiple gases can be monitored, generally no more than 2-5
	v. Fourier transform infrared (FTIR)	Extractive / In-situ Path	CO, CO <sub>2</sub> , SO <sub>2</sub> , NO <sub>x</sub> , HCl, HF etc.	Multiple gases can be monitored, typically 5+
	vi. Photoacoustic (PAS)	Extractive	CO, CO <sub>2</sub> , SO <sub>2</sub> , HCl, HF,	Can measure virtually any gas that

	Monitoring technique	Sampling Type	Pollutant measured	Note
			NO, NO <sub>2</sub> , NH <sub>3</sub> , VOCs, H <sub>2</sub> O	absorbs IR. Detailed analysis of other compounds that may be present other than target gases required
<b>2</b>	<b>Luminescence methods</b>			
	i. Fluorescence	Extractive	SO <sub>2</sub> , H <sub>2</sub> S <sup>a</sup> , TRS <sup>a</sup>	<sup>a</sup> can also be measured but not simultaneously
	ii. Chemiluminescence	Extractive	NO, NO <sub>x</sub> , NO <sub>2</sub> <sup>b</sup>	<sup>b</sup> NO <sub>2</sub> calculated (NO <sub>x</sub> – NO)
<b>3</b>	<b>Electroanalytical methods</b>			
	i. Electrochemical O <sub>2</sub>	Extractive	O <sub>2</sub>	
	ii. Paramagnetism	Extractive	O <sub>2</sub>	
	iii. Zirconia oxide cell	In-situ	O <sub>2</sub>	Widely used, maximum temperature generally 500oC
<b>4</b>	<b>Other methods</b>			
	Flame Ionization Detector (FID)	Extractive	Total HC	Requires hydrogen carrier gas.
	Tunable Laser Diode (TLD)	In-situ Path	HCl, HF, NH <sub>3</sub> , CH <sub>4</sub> , CO, CO <sub>2</sub> , H <sub>2</sub> O	Cost effective for single component applications.
<b>5</b>	<b>Particulate Matter</b>			
	Extinction	In-situ Path	PM, Opacity	
	Dynamic Opacity	In-situ Path	PM, Opacity	
	Light Scatter	In-situ Path	PM	Forward, Side or Backward Light Scattered
		Extractive	PM	For wet monitoring
	Probe Electrification	In-situ Point	PM	e.g. Tribo-electric probe
	Beta Absorption	Extractive	PM	

**Table 3.2 – Typical analytical techniques used in CEM system**

**Table 3.3 – Substance to monitor with applicable monitoring technique**

Substance	Type of sampling CEMS	Monitoring technique	Further information
Carbon dioxide; CO <sub>2</sub>	In-situ	NDIR	CO is a positive cross interferent. Methane also interferes.
		DOAS	Simultaneous monitoring of CO <sub>2</sub> along with many other pollutants. Range up to 100%, LOD approx. 0.1% by volume.
	Extractive	NDIR analyzer	Interference from CO, water, methane and ethane.
		FTIR analyzer	Simultaneous monitoring of CO <sub>2</sub> along with many other pollutants. Faster response than NDIR. Typical range 0 to 35%
Carbon Monoxide; CO	In-situ	NDIR	Measurement of CO and CO <sub>2</sub> . CO <sub>2</sub> are positive cross interferents. Methane also interferes, primarily with CO <sub>2</sub> . LOD <3 mg/m <sup>3</sup> .
		DOAS	Measurement of CO and CO <sub>2</sub> . Typical range up to 10,000 mg/m <sup>3</sup>
	Extractive	NDIR	Interference from water, methane and ethane
		Electrochemical cell	Requires appropriate conditioning and purging with clean air for sensor recovery
		FTIR	Measurement of CO and CO <sub>2</sub> . Wide range typically up to 10,000 mg/m <sup>3</sup> ; short response times; low LODs. Reduced interferences compared to NDIR
Hydrogen Chloride; HCl	In-situ	DOAS	Measures HCl, specifically, rather than total chlorides. Simultaneous monitoring of HCl along with many other pollutants. Measures gas-phase HCl only. Range up to 5000 mg/m <sup>3</sup> , LOD <1 mg/m <sup>3</sup> . Not suitable for the measurement of chlorides
		Tunable diode laser	
		NDIR analyzer	

**Table 3.3 – Substance to monitor with applicable monitoring technique**

Substance	Type of sampling CEMS	Monitoring technique	Further information
	Extractive	NDIR analyzer	Interference from particulates, H <sub>2</sub> O, CO, CO <sub>2</sub> and any other IR-absorbing components.
		FTIR	Measures HCl, specifically, rather than total chlorides Simultaneous monitoring of HCl along with many other pollutants. Faster response and fewer interferences than NDIR. Typical range up to 1000 mg/m <sup>3</sup> . Measures gas phase HCl only.
		Ion mobility spectrometry	LOD down to ppb levels
		Continuous-flow analyzers, based on IC, ISE etc.	Simultaneous monitoring of chloride expressed as HCl along with many other halides. Measures gas phase only. Not specific to HCl (also responds to chlorides). Interference from particulates, H <sub>2</sub> O, CO <sub>2</sub> , Cl <sub>2</sub> , SO <sub>2</sub> , SO <sub>2</sub> , NO <sub>2</sub> and NH <sub>2</sub> . Slow response time, require consumable reagents
<b>Hydrogen Fluoride; HF</b>	In-situ	DOAS	Can measure gas-phase HF. Does not measure fluoride salts. For HF, range is 0-1,000 mg/m <sup>3</sup> , LOD 0.2 mg/m <sup>3</sup>
		Extractive	NDIR analyzer
	FTIR	Applicable to gas-phase HF. Reduced interference compared to NDIR and faster response. Does not fluoride salts	
	IMS	Can measure gas-phase HF. Suitable for ppb levels.	
	TDL	Can measure gas-phase HF.	
	Continuous-flow analyzers, based on IC, ISE etc.	Instruments available for measuring gas-phase HF. Measures halides absorbed into collection solution. Interference from particulates, CO <sub>2</sub> , SO <sub>2</sub> , SO <sub>3</sub> , NO <sub>2</sub> and NH <sub>3</sub> . Require	

**Table 3.3 – Substance to monitor with applicable monitoring technique**

Substance	Type of sampling CEMS	Monitoring technique	Further information
			consumable reagents.
Nitrogen Monoxide; NO and Nitrogen Dioxide; NO <sub>2</sub>	In-situ	NDUV	Measurement of NO and NO <sub>2</sub> . The principal interference is from SO <sub>2</sub> .
		DOAS	Measurement of NO, NO <sub>2</sub> . Typical range up to 2,000 mg/m <sup>3</sup> , LOD <1 mg/m <sup>3</sup>
		NDIR	Measurement of NO and NO <sub>2</sub> . Wide range (typical NO to 5,000 mg/m <sup>3</sup> , NO <sub>2</sub> to 5,000 mg/m <sup>3</sup> ).  Main interference from particulates and H <sub>2</sub> O, which can be reduced by precise selection of wavelength. Not suitable for high-moisture gases.
	Extractive	NDUV	As above for in-situ CEMs
		NDIR	As above for in-situ CEMs. Main interference from particulates and H <sub>2</sub> O, which can be removed by conditioning.
		Chemiluminescence	Measurement of NO and NO <sub>2</sub> . Very low LOD (typically 0.1 ppm); wide range (typically 0-10,000 ppm); short response (a few seconds).  The principal interference is from CO <sub>2</sub> , H <sub>2</sub> O and NH <sub>3</sub> .
		Electrochemical	Measurement of NO and NO <sub>2</sub> typically up to 3,000 ppm and 500 ppm, respectively. Requires appropriate conditioning and purging with clean air for sensor recovery.
		NDIR	Measurement of N <sub>2</sub> O. Steps required to reduce potential interference effects of CO, CO <sub>2</sub> and moisture.
		FTIR analyzer	Simultaneous monitoring with many other pollutants. Faster response and

**Table 3.3 – Substance to monitor with applicable monitoring technique**

Substance	Type of sampling CEMS	Monitoring technique	Further information
			less interference than NDIR. Measurement of NO, NO <sub>2</sub> and N <sub>2</sub> O.
Oxygen; O <sub>2</sub>	In-situ	Zirconium oxide film	Main interferences: hydrocarbons, CO.
	Extractive	Paramagnetic analyzer	Range 0-100% with typical resolution of 0.1%. Interference from high concentrations of NO <sub>2</sub> , NO and certain hydrocarbons.
		Electrochemical cell	Electrochemical cell can also be mounted in the gas stream for an in-situ CEMs measurement.  Interference from SO <sub>2</sub> , NO <sub>x</sub> and acid gases. Requires appropriate conditioning and purging with clean air for sensor recovery.
		Tunable diode laser	
		Zirconium oxygen gas analyzer	
Particulate Matter; PM	In-situ	Optical Extinction or Scintillation (Opacity meter or Transmissometer)	Opacity or smoke density measurements. Laser opacimeters have LOD down to 1 mg/m <sup>3</sup> .  Does not measure mass of particulates directly.  Concentration calibration factor dependent on particle size, composition, shape, colour and refractive index.  Gives a measure of particulate concentration after calibration with gravimetric SRM. Typical range about 10 to 2000 mg/m <sup>3</sup> . Not suitable for low concentration emissions.
		Tribo-electric probe (probe electrification)	Can be used simply as an alarm indicator or as quantitative monitor. Claimed to be suitable for low particulate concentrations (LOD less than 1 mg/m <sup>3</sup> ). Tribo-electric response

**Table 3.3 – Substance to monitor with applicable monitoring technique**

Substance	Type of sampling CEMS	Monitoring technique	Further information
			dependent on particle size, composition and moisture. Gives a measure of particulate concentration after calibration against SRM.
		Light scattering (Forward, Side or Backward Light Scattered)	Reported to be suitable for low particulate concentrations (LOD down to 1 mg/m <sup>3</sup> ). Gives a measure of particulate concentration, but only after calibration with SRM.
	Extractive	Beta-attenuation monitor	Can be calibrated to give particulate concentration in mg/m <sup>3</sup> directly. Gives successive average readings over set sampling periods. Absorption coefficient is independent of particulate composition. Typical range about 2 to 2,000 mg/m <sup>3</sup> depending on sampling rate, frequency and integrating time.
		Extractive light-scattering	Suitable for low particulate concentrations. Extractive part of the system may retain particulates. Manufacturer's data: range 0-1000 mg/m <sup>3</sup> ; LOD 0.02 mg/m <sup>3</sup> ; reproducibility 0.5% FSD.
Sulphur dioxide; SO <sub>2</sub>	In-situ	NDUV	Low limit of detection. Wide linear response range. Short response times. Monitoring by NDUV is the most commonly encountered CEMS technique. The principal interference is from H <sub>2</sub> O and NO <sub>2</sub> .
		DOAS	Simultaneous monitoring of SO <sub>2</sub> along with many other pollutants. SO <sub>2</sub> range up to 2000 mg/m <sup>3</sup> , LOD <1 mg/m <sup>3</sup> .
		NDIR	Low limit of detection. Wide linear response range. Short response times. Common interference from particulates, H <sub>2</sub> O, CO, CO <sub>2</sub> , NO, NO <sub>2</sub> , SO <sub>3</sub> , unsaturated hydrocarbons, aromatic amines and nitro-

**Table 3.3 – Substance to monitor with applicable monitoring technique**

Substance	Type of sampling CEMS	Monitoring technique	Further information
			compounds. Not suitable for ducts with high moisture content.
	Extractive	UV-fluorescence and UV- absorption	Particulates and H <sub>2</sub> O can be removed by conditioning, leaving NO <sub>2</sub> as the principalinterferent.
		IR-absorption	Particulates and H <sub>2</sub> O can be removed by conditioning, leaving as the principal interferents CO, CO <sub>2</sub> , NO, NO <sub>2</sub> , SO <sub>3</sub> , unsaturated hydrocarbons, aromatic amines and nitro-compounds.
		Electrochemical	Typical range up to 5000 ppm. Can also be installed in situ in duct. Requires periodic purging with pure air for the sensor to recover. Removal of particulates and moisture is necessary to stop the condensation and dissociation of salts.
	FTIR	Simultaneous monitoring of many pollutants. Faster response and fewer interferences than NDIR.	
<b>VOCs (total)</b>	Extractive	FID analyser	Validated on waste incinerators. High specificity to VOCs. Developed for incinerators. Different response factor for each VOC species. Suitable for low ranges of VOC concentrations (0-20 mg/m <sup>3</sup> ). Interference from oxygen (reduced by mixed H <sub>2</sub> /He fuel).
			Extensively validated for solvent processes. High specificity to VOCs. Different response factor for each VOC species. Suitable for VOC concentrations up to 500 mg/m <sup>3</sup>
<b>VOCs (speciated)</b>	In-situ	DOAS	Can measure certain specific organic compounds, e.g. benzene, toluene and xylene. Benzene typical range 0-1,000 mg/m <sup>3</sup> , LOD 1 mg/m <sup>3</sup> ; toluene

**Table 3.3 – Substance to monitor with applicable monitoring technique**

Substance	Type of sampling CEMS	Monitoring technique	Further information
			typical range up to 1,000 mg m <sup>-3</sup> , LOD 0.5 mg/m <sup>3</sup> ; xylene typical range up to 1,000 mg/m <sup>3</sup> , LOD 1 mg/m <sup>3</sup>
	Extractive	Continuously-cycling GC with appropriate detector (FID, ECD)	Can measure virtually any individual organic compounds, many simultaneously. Not truly continuous, but successive measurements in cycles of about 30 minutes. LOD typically 1 ppm.
		FTIR analyser	Can measure many individual organic compounds simultaneously, with better specificity, LOD (at ppb level) and better response than NDIR.
		NDIR analyser	Can measure many individual organic compounds, but only one at a time. Instrument must be set up specifically for the determine and of interest. Interferences from H <sub>2</sub> O and other species with overlapping spectra.
<b>Water vapour (moisture)</b>	In-situ	NDIR	In widespread use. Interference from other IR absorbing species, e.g. CO, CO <sub>2</sub> hydrocarbons.
		DOAS	Simultaneous monitoring of H <sub>2</sub> O and other pollutants. Typical range 0-30%, LOD approx. 0.1% volume.
	Extractive	NDIR analyzer	Interference from CO, CO <sub>2</sub> , hydrocarbons.
		FTIR analyzer	Simultaneous monitoring of H <sub>2</sub> O and other species. Faster response than NDIR. Typical range 0 to 35%.
		Paramagnetic analyzers	Range 0-100%, typical resolution 0.1%. H <sub>2</sub> O calculated from the difference between two analyzers, one measuring O <sub>2</sub> wet and other dry. Not a direct measurement of moisture. Interferences from high concentration of NO <sub>2</sub> , NO and hydrocarbons.

### 3.4 Data Acquisition Handling System (DAHS/DAS)

3.4.1 A CEM system is not complete without incorporating a subsystem that records the data produced by the monitors/analyzers. The data acquisition handling system (DAHS/DAS) provides this record of emission measurements. Activities such as reviewing data and log, checking calibration values, responding to excess emissions problems and generating reports are all performed within the DAHS. **Figure 3.6** gives summary of CEM system control and data acquisition and handling function.

3.4.2 The essential function of the DHAS is display, recording, and reporting. The features of DHAS shall be consider include the following features:

- a) Default screen - Half hour and daily summaries – to showing the compliance with emission limit value.
- b) Showing real-time or/and averaged data (1 minute, 30 minutes and daily average).
- c) Alarm screen - showing the alarm (calibration failure, excess emission and fault alarm) occurring over a specified period
- d) Calibration report – showing calibration gas certified values, instrument response, drift and percentage drift.
- e) The system should provide a continually updated display of parameters measured and corrected by the monitoring system. The display should provide easily readable formats in one screen or several screen.
- f) The system should have the capability to display raw, real time, averaged, normalized and historical data.
- g) It should be possible to display historical data in trend plots. Trend plot should be from minutes, half hours, daily, monthly and yearly.
- h) The system display information should be able to be printed.
- i) Calibration drift data should be presented in quality control charts, updated automatically after each calibration check.
- j) If possible, colour should be used to block set of data, highlight suspect data, highlight alarm, and in general provide visual interest and alert to operator, user or auditor.
- k) If possible, graphic should be used to visualize the stack or outline of the CEM system condition.

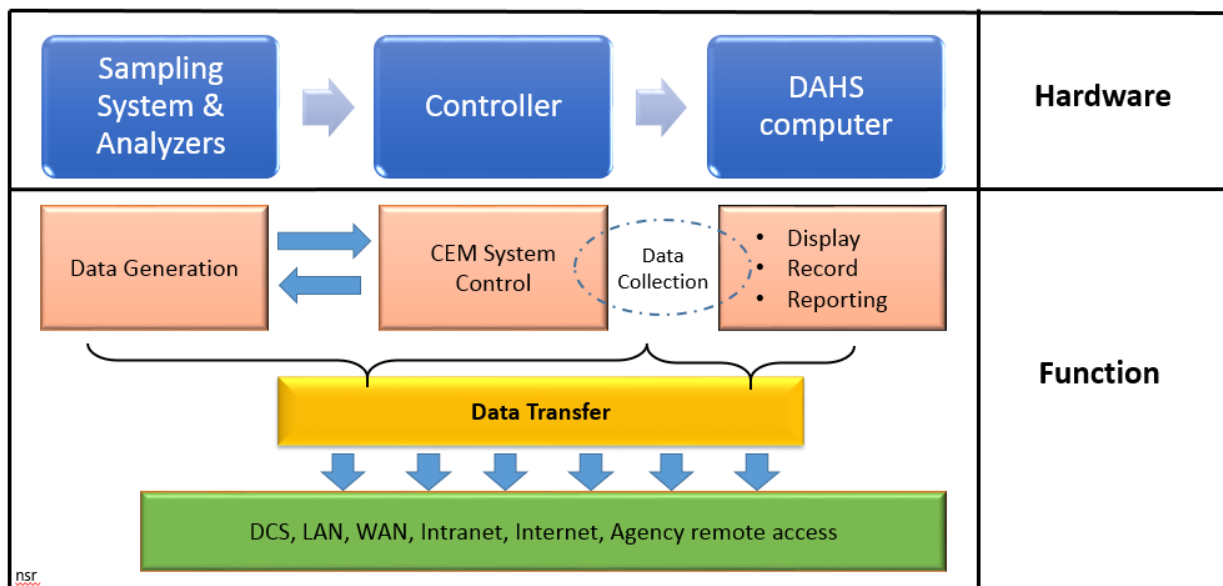

**Figure 3.6–CEM system control and DHAS functions**(James A Jahnke)

### 3.5 Data Interface System (CEMS-DIS)

- 3.5.1 The CEM system must be designed to transmit data to the DOE and the protocol used to transmit data via internet connectivity (e.g. a broadband other telecommunications system) should follow a data telemetry access protocol. This should be done by preparing an intermediary component called CEMS Data Interfacing System (CEMS-DIS) to store CEM data from DAS and communicate with centralized DOE server for CEMS data transferring purposes
- 3.5.2 Volume II: Guideline for the Continuous Emission Monitoring System – Data Interface System (CEMS-DIS) for Industrial premises / Facilities is the guideline for the developing and implementing CEMS-DIS with standard data format and units of the standards for the transmission of data to the DOE.
- 3.5.3 All the transferred data, can view and access by plant operator itself and DOE through iRemote System developed by DOE.

# Chapter 4 – CEM System Requirements

Installation of CEM system at plant operator's facility requires application to DOE beforehand and must be installed by a registered CEMS consultant/supplier. The CEM system that propose to install and operate must follow the DOE requirement which involve design specification, installation requirement and initial performance audit procedures.

## 4.1 Design Specifications

- 4.1.1 Each and every analyzers and CEM component or equipment installed as a CEM system for compliance monitoring and reporting should be in compliance with one or more of the international standards
  - a) United Kingdom Monitoring Certification Scheme (MCERTS) – EN15267-3 & EN14181 QAL1 or
  - b) German Technical Inspection and Monitoring Union (TUV) QAL1- EN15267-3 & EN14181 QAL 1 or
  - c) Malaysian Standard MS 2564:2014 - Performance Criteria and Test Procedure For CEMS.
- 4.1.2 CEM system shall be able to provide valid data average as mention in sub chapter 2.3 of this guidelines.
- 4.1.3 The emission value of CEM system shall be calculated in term of mass of pollutant per volume of the waste gases (expressed as mg/m<sup>3</sup>), assuming standard conditions for temperature and pressure (STP) for dry gas (volume at 273K, 101.3 kPA)
- 4.1.4 The emission value of CEM system shall be normalize to reference gas (if applicable) as mentioned in Second Schedule and Third Schedule of CAR 2014.
- 4.1.5 The CEMS data recorder output range must include zero and high level value. The high level value of measuring range must between 2 times the emission limit value (ELV).
- 4.1.6 Certified CEM system states the certified range. The certification range can indicate the suitability of a CEM for a particular application. For selecting suitable CEMS, the lowest certified range shall not more than 2.5 times emission limit value.
- 4.1.7 CEM system shall also be able to measure instantaneous values over the ranges which are to be expected during all operating conditions. If it is necessary to use more than one range setting of the CEM to achieve this requirement, the CEM shall be verified for monitoring supplementary higher certified range.
- 4.1.8 CEMS Response time must be less than 200 seconds

4.1.9 Measurement uncertainty - the CEM system shall meet the measurement uncertainty requirements as specified in Table 4.1 below or other equivalent requirements acceptable to the Authority

<b>Emission Parameter</b>	<b>Values of the 95% confidence intervals of a single measured</b>
Carbon Monoxide	10%
Sulphur Dioxide	20%
Nitrogen oxides / Nitrogen Dioxide	20%
Dust/ Total Dust	30%
Total Organic Carbon	30%
Hydrogen Chloride	40%
Hydrogen Fluoride	40%

**Table 4.1 - Requirement on the measurement of uncertainty of CEM system**

4.1.10 Functionality of CEMS

- a) All CEMS must have provision that allow either plant operators, CEMS suppliers or CEMS audit tester to perform zero check, span check and linearity test once CEMS has been installed;
- b) Extractive CEMS must have the means for leak checks, such as the provisions for applying test gases at the sampling probe to prove the integrity of the entire sampling system and
- c) Such provision could also be used to test the response time of the entire system
- d) For particulate matter CEM, the reference materials used in the automatic or manual zero check and span check should be documented by the manufacturer and assessed as part of certified CEMS

4.1.11 The CEM system must be designed to be able to perform zero and span check:

- a) Zero and span check shall be performed using reference material such as calibration gas, or surrogates (such as filter or field current);
- b) Zero and span level for reference material shall follow below:
  - i. For Gas; Zero level (0-20%) of span value and span level (80-100%) of 2 times emission limit value daily average;
  - ii. For Opacity: low level (0-10%) and span level of (40-60%)
  - iii. For PM: low level (0-10%) and span level of (50-100%) of the full-scale measurement range (max. mg/m<sup>3</sup>).
- c) Frequency of zero and span check shall be performed based on the maintenance interval specify in certification CEM (QAL1);
- d) Even there is certified CEMS with zero and span check either automatic or manual, DOE preferred CEMS with automatic zero and span check since this test can be conducted without additional work or personnel.

4.1.12 For extractive CEMS, use sampling system specified in the certificate. It shall consist of component below:

- a) Sample probe – should be made by the approved material and suits with flue gas characteristic and temperature. It must have a sufficient length to insure that a representative sample is drawn.
- b) Sample line from the probe to the conditioning system/sample pump, should be made by approved material that does not absorb or otherwise alter the sample gas. The temperature of the sample line (heated sampling line) must be maintained at sufficiently high level (>180°C or above sample dew point) to prevent condensation before the sample conditioning component / analyzer
- c) Conditioning equipment – for dry basis measurement, a condenser, dryer or other suitable device is required to remove moisture continuously from the sample gas.
- d) Particulate filter (in stack or out of stack filter), the filter must be made of material that is nonreactive to the gas being sample.
- e) Calibration gas manifold system – should be prepared to allow introduction of calibration gases. Two (2) calibration mode involve; direct calibration mode (calibration gases direct to analyzer) and system calibration mode (calibration gas direct to the probe and flow to through CEM system to analyzer)

4.1.13 Extractive CEMS must not deviate from the type of sampling system specified in certificate to ensure CEMS is not degraded, such that it no longer meets the required performance specifications. Such allowable variations could include:

- a) A different length of sampling line to that which was tested.
- b) A different brand or model of sampling train, so long as there is evidence from third-party testing that the alternative components meet the required performance specifications and have been tested.
- c) Additional manifolds and heated valves used to allow more than one analyser to share a sampling train.

Any other changes to the system would require a review of the changes by the DOE

4.1.14 Data acquisition handling system (DAHS) of CEM system shall be able to perform basic function which include those associated with system control (if applicable), data acquisition and correction and data handling function such as display, recording and reporting as mention in subchapter 3.4 of this guidelines.

4.1.15 All measurement from CEMS must be retained on file by the operator for at least 3 years.

## 4.2 Installation Specifications

4.2.1 Three (3) overriding principles for CEM system installation are:

- a) The measurements must be representative of the actual stack emission,
- b) The effluent gases are well mixed.
- c) The sampling location should be accessible for system maintenance and repairs.

4.2.2 CEMS measurement location. The measurement location should be follow as below as a guide to facilitate the installation of CEM system at representative locations. Any other deviation needs to seek consent from DOE.

- a) Five (5) equivalent internal stack diameter downstream and five (5) equivalent internal stack diameter upstream of any flow disturbances and
- b) Five (5) equivalent internal duct diameter downstream and two (2) equivalent internal duct diameter upstream of any flow disturbances and
- c) For Opacity or PM (in-situ system), the consideration below must take into account when to selecting measurement location:
  - i. Water droplets (condensed water vapor) are not to be present at the monitoring location.
  - ii. If the monitor responds to ambient light, it is to be located at a point where ambient light is not present (away from either the top of the stack or where light leaks into the ductwork).

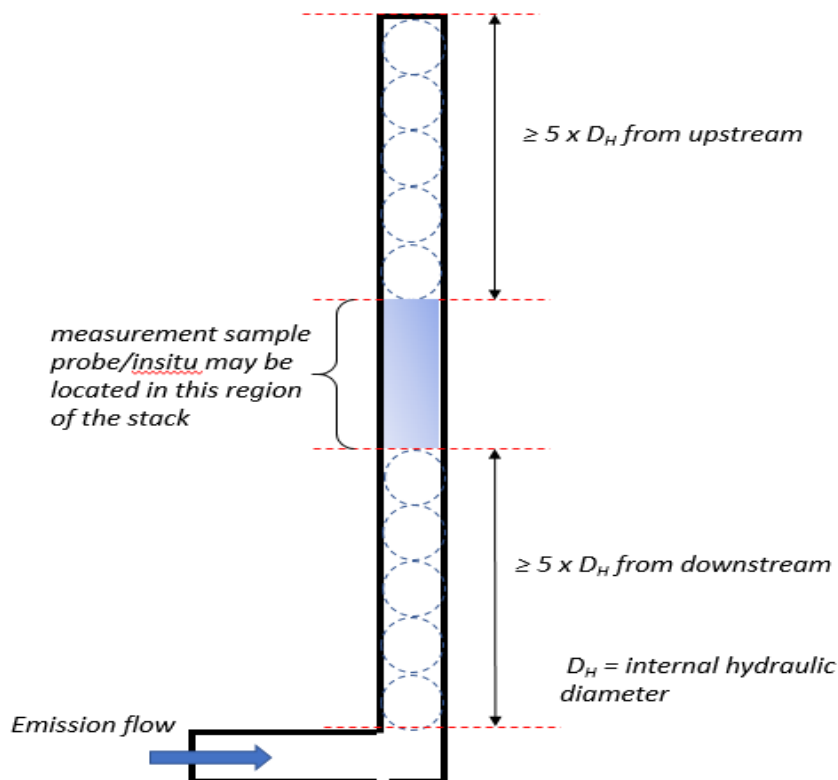

Figure 4.1 - Sampling probe location

4.2.3 The monitor or probe is to be accessible to permit routine maintenance. Accessibility is also important for the performance of calibration audits and alignment checks.

4.2.4 For Point CEMS sampling system, the measurement point should be

- a) No less than 1.0 meter from the stack or duct wall or
- b) Centrally located over the centroidal area of the stack or duct cross section

as illustrated in **Figure 4.2**

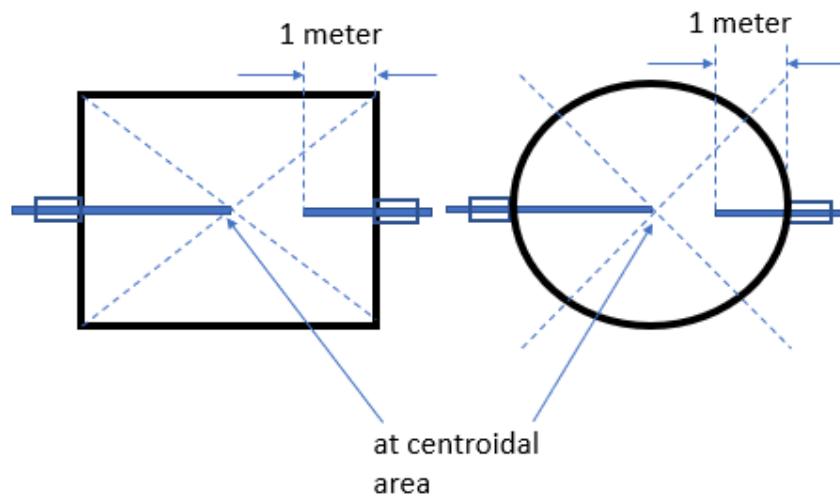
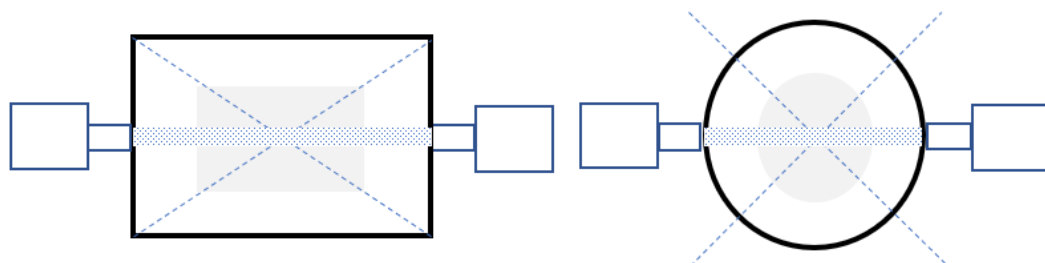

**Figure 4.2 – Measurement point for Point CEMS**

4.2.5 For Path CEMS sampling system, the measurement path should be

- a) Totally within the inner area bounded by a line 1 meter from the stack or duct wall or
- b) Have at least 70 percent of the path within the inner 50 percent of the stack or duct cross-sectional area, or
- c) Centrally located over any part of the centroidal area

as illustrated in **Figure 4.3**



**Figure 4.3 – Measurement point for Path CEMS**

- 4.2.6 Standard Reference Method (SRM) measurement location should be prepared accordingly same to para 4.2.2 for quality assurance purpose of CEM system.
- 4.2.7 Industry to ensure availability of permanent, strong & reliable platforms at CEMs monitor/probe mounting location with safe approach ladders or stair case or elevator.
- 4.2.8 All the power cables, signal cable, instrument air tubing's should be properly laid & clamped.
- 4.2.9 All CEMs component should be label and schematic diagram of CEM system should be display at appropriate CEMs location (CEM shelters / cabinet)

# Chapter 5 –Quality Assurance Program

## 5.1 Quality Assurance Programs

- 5.1.1 A quality assurance (QA) program is basically a management program developed to assure that quality control (QC) activities are performed. These QC activities such as daily calibration, regularly performance audits and maintenance activities should be comprised as a set of standard operating procedures (SOPs), which are then incorporated into a quality assurance plan (QAP)
- 5.1.2 A Quality Assurance Plan (QAP) must be written (and become QA manual), implemented, maintained and followed. It must include and describe a complete program of activities to be implemented that will ensure that the data generated by the CEMS is complete, accurate, precise, traceable and reliable.
- 5.1.3 The outline for a CEM system QA manual is given in **Table 5.1**. Other procedures can be institute to further assure the accuracy and precision of the CEM system data.

No	Outline for CEM System Quality Assurance Manual
1	CEM regulatory mandates and CEM system description
2	Organization and responsibilities
3	Facilities, equipment and spare parts inventory
4	CEM system operating manual
5	Functional Test procedure
6	QAL2 - Calibration and Variability Test (CVT)
7	QAL3 - On-Going Performance Monitoring (OGPM)
8	Annual Surveillance Test (AST)
9	Corrective action procedures
10	System audit procedures
11	Data backup procedures
12	CEM system security
13	Data reporting procedure
14	Reference
15	Blank form

**Table 5.1: Outline for a CEM System Quality Assurance Manual**

5.1.4 The QA manual as outline in **Table 5.1**, must satisfy the Quality Assurance and Quality Control of CEMS as listed below which are necessary to ensure accuracy, precision, traceability and reliability of the CEM data and information of all the time:

- a) **Design and Installation Requirement** – is a process by which suitable CEMS is selected. This requires a procedure to demonstrate to regulator (DOE) that the CEMS is potentially suitable for it purpose before installation. The criteria already described in Chapter 4 of this guidelines.
- b) **QAL2 - Calibration and Variability Test (QAL2-CVT)**- is procedure for calibrating CEMS against the appropriate Standard Reference Method (SRM). The SRM is deemed to provide the correct results within certain tolerances. The process also verifies the installation of the CEMS through functionality testing, and that it meets the measurement uncertainty requirements.
- c) **QAL3 - On-Going Performance Monitoring (QAL3-OGPM)**- procedures that are performed on a routine basis, generally daily, weekly, monthly or during maintenance interval time, to determine whether the system is functioning properly. These procedures include zero and calibration checks and visual checks of CEM system operating indicators such as vacuum and pressure gauge, rotameters, control panel and so on.
- d) **Annual Surveillance Test (AST)**–a procedure to evaluate CEM on a yearly basis to show that it continues to function correctly, the calibration function remains valid, and that the variability remains within acceptable levels. The process involves carrying out functionality testing and parallel measurements on the CEMS.

5.1.5 These quality assurance levels follow a logical sequence and aim to demonstrate the correct selection, installation, calibration and continuously valid operation of the CEMS at plant operator's facility. These are shown in **Figure 5.1**

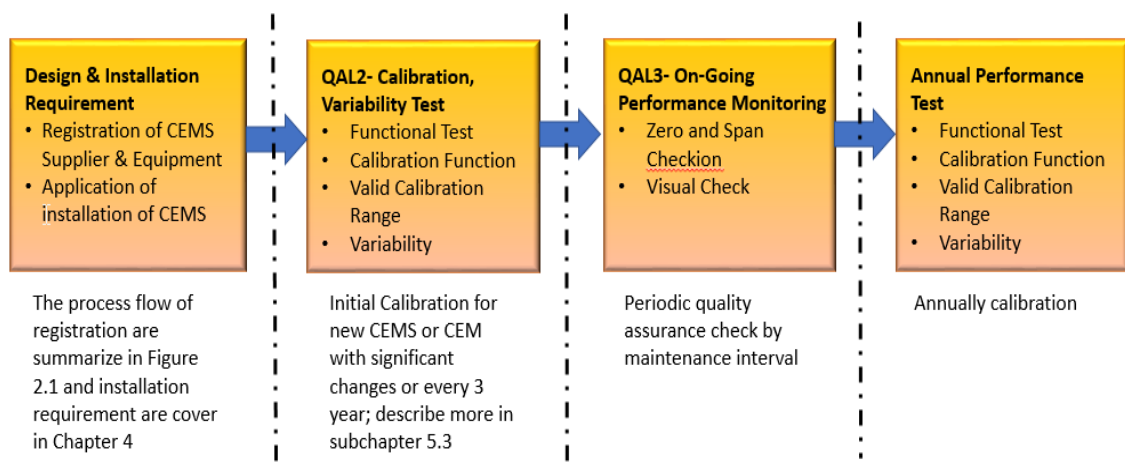

**Figure 5.1: The Sequence of Quality Assurance and Quality Control activities**

## 5.2 Functional Test

- 5.2.1 Functional test must be taken before any QAL2-CVT or AST is carried out, as separate event.
- 5.2.2 These tests shall be carried out no more than one month before the parallel measurements with SRM for calibration function & variability test during QAL2-CVT or AST
- 5.2.3 The functional test may be performed by plant operator, CEM audit tester or CEM supplier and they should be recognised and approved by DOE.
- 5.2.4 The requirements for functional tests are listed in **Table 5.2**.
- 5.2.5 Functional test are required for oxygen and moisture (if applicable)
- 5.2.6 Additional guidance describing each activity required during the audit and functional test format report can be found in **Appendix 3**

Functional test activity	Calibration and Variability Test (QAL2-CVT) & Annual Surveillance Test (AST)		Responsibilities
	Extractive CEMS	In-Situ CEMS	
Alignment & cleanliness		/	Plant Operator/ CEMS Tester
Sampling Train	/		Plant Operator/ CEMS Tester
Documentation and records	/	/	Plant Operator/ CEMS Tester
Serviceability	/	/	Plant Operator/ CEMS Tester
Leak Test	/		Plant Operator/ CEMS Tester
Zero and span check	/	/	Plant Operator/ CEMS Tester
Linearity	/	/	Plant Operator/ CEMS Tester
Interferences	/	/	Plant Operator/ CEMS Tester
Zero and span drift (audit on On Going Performance Monitoring)	/	/	Plant Operator/ CEMS Tester
Response time	/	/	Plant Operator/ CEMS Tester
Report	/	/	CEMS Tester

**Table 5.2: The requirements for functional tests**

### 5.3 Calibration and Variability Test (QAL2-CVT)

5.3.1 Calibration and Variability Test is the test required to accept or certify CEM system installation and operation at the plant and should be conducted prior to CEM data connection to DOE can be made.

5.3.2 QAL2-CVT procedure is required to carry out on installation in the following situations

- a) Within 3 months of the commissioning of a new CEM system;
- b) At least every three (3) years for all CEMS installation required under CAR14
- c) If QAL3-OGPMEvaluation or AST demonstrates a need for a QAL2-CVT;
- d) If there are significant changes, upgrades or repairs to the CEMS, which will influence and change the results significantly (see following paragraph 5.2.3);
- e) If there is a change of fuel (see following paragraph 5.2.3);
- f) Whenever there is a significant change in plant operation, which changes the emissions.
- g) If the CEMS exceeds the limits for operating outside the valid calibration range(see following paragraph 5.2.5).

5.3.3 Changes to the plant or fuel can have an effect on the emissions profile of the process and may require a new QAL2-CVT procedure. The following is considered a significant change in fuel:

- a) The change in fuel alters the flue gas emission profile.
- b) The change in fuel results in a licence revision.
- c) The fuel is changed from one to another of the following types – solid, liquid, and gaseous.
- d) The fuel is changed from a single type to a mixture of fuel types, or vice versa.
- e) The thermal input is more than 10% per year for the alternative fuel.

5.3.4 If there are significant changes to plant or fuel (as mentioned in 5.2.3), the plant operator can prove that the calibration function is still valid (not changed), by performing AST to provide evidence. If the AST shows that the calibration function is still valid, through a pass of the variability test and acceptance test, then a new QAL2-CVT is not required.

5.3.5 If CEMS measured values exceed the valid calibration range, a new QAL2-CVT may be required. This is necessary if either of the following occurs:

- a) More than 5% of CEMS calibrated and standardised values during a weekly period are outside the valid calibration range for more than five weeks between two AST.
- b) More than 40% of CEMS calibrated and standardised values during a weekly period are outside the valid calibration range for one or more weeks.

- 5.3.6 Once the need for a new QAL2-CVT has been triggered, the new calibration function must be implemented as soon as practicable but within three (3) months. During this time the previous calibration function must be used until the new calibration function has been determined.
- 5.3.7 This QAL2-CVT procedure should be conducted by a source testing contractor (CEM Audit Tester) approved by DOE, who able to conduct parallel measurement CEMS with SRM, then to determine calibration function, valid calibration range and variability test.
- 5.3.8 Calibration function test procedure:
- a) Calibration function test required parallel measurement CEMS with SRM.
  - b) Required at least 15 parallel measurements spread over three (3) days. Three (3) days do not need to be consecutive but must performed within a period of at most 4 weeks.
  - c) Plant operator and CEMS audit tester should select a time when the emissions are likely to be at the highest and most varied. However, an industrial process may not be deliberately varied outside normal operational conditions, in order to create higher than normal emissions.
  - d) The calibration procedure needs a good spread of concentrations to provide reliable calibration function. This approach may not be possible due to process type and plant conditions. For that, one (1) of three (3) situations, will arise during parallel measurement and will have different procedure to calculate calibration function. This summarize in **Table 5.3**
  - e) Lag time – CEMS audit tester shall have procedure to determine the lag times and for matching the data from CEMS and RM accordingly.
  - f) Outliers data – CEMS audit tester shall eliminate any outlier data by conducted outlier test. However, if calculate coefficient of calibration function;  $R^2$  show  $R^2 > 0.90$ , then is not necessary to perform an outlier test.
  - g) At least one (1) of 15 data must be at zero or near zero (near zero defined as value 5% or less of ELV). Zero values should be measured when the installation is not producing emissions. If this is not possible, then reference materials shall be used to determine the CEM's response to zero values of the emissions pollutant.
  - h) Calibration function for NO<sub>x</sub> - **Table 5.4** summarises the approach to use generating calibration function for NO<sub>x</sub>.
  - i) Calibration function of Oxygen and Moisture – not necessary if emissions pollutant is passing the variability test. If not, same QAL2-CVT procedure are required for Oxygen and Moisture to conduct calibration function and variability test; by referring:

- i. O<sub>2</sub> ELV = 21% and 95% CI = 10% ELV and
- ii. Moisture ELV=30% and 95%CI = 30% ELV

5.3.9 Valid calibration range- is determined at the same time the calibration function is calculated where highest calibrated CEMS parallel measurement at standard conditions plus 10% (or plus 100% for particulate CEMS) of the ELV

$$\text{Valid calibration range (VCR)} = 0 \text{ to } 110\% \times \text{CEMS}_{\text{calibrated, std condition}}$$

5.3.10 Variability Test - Carry out variability test and then do assessment (pass-fail criteria) for variability result. **Table 5.5** list all related variability test equation and criteria

5.3.11 **Figure 5.2** shows the summary in flow chart for conducting Calibration and Variability Test begin with Functional test until Variability Test.

5.3.12 The Calibration and Variability Test report shall be prepared submitted to DOE for verification. The test report should be well organized, readable, and complete. All data, including softcopy and hardcopy raw data necessary to recalculate any of the reportable parameters, should be included in the report. **Appendix 4** listed the items that are to be reported

Situation Arise	Procedure to determine calibration function
<p>Situation 1 - A good spread of data. A dataset is deemed to have a wide spread when the difference between the highest and lowest SRM parallel measurements at standard conditions is greater than the maximum permissible uncertainty.</p> <p><b>(SRM<sub>max</sub>-SRM<sub>min</sub>) &gt; 95%CI of daily average ELV</b></p>	<p>Use procedure A</p> <p>requires confirmation of CEMS can read zero (during plant turned off or use surrogate zero)</p> <p>Calibration Function equation:</p> $y = bx + a$ $b = \frac{\sum_{i=1}^n (x_i - \bar{x})(y_i - \bar{y})}{\sum_{i=1}^n (x_i - \bar{x})^2}$ $a = \bar{y} - b\bar{x}$ <p>where <math>y = \text{CEM}_{\text{calibrate}}</math>, <math>x = \text{CEM}_{\text{measure}}</math></p>
<p>Situation 2-A high-level cluster, this occurs when there is little variation in emissions. A data set is defined as a high-level cluster when the difference between the highest and lowest SRM parallel measurements at standard conditions is less than the maximum permissible uncertainty, and the lowest SRM parallel measurement at standard conditions is greater than 15% of the ELV.</p> <p><b>(SRM<sub>max</sub>- SRM<sub>min</sub>) &lt; 95%CI of daily average ELV and SRM<sub>min</sub> ≥ 15% of daily average ELV</b></p>	<p>Use procedure B</p> <p>requires confirmation of CEMS can read zero (during plant turned off or use surrogate zero)</p> <p>Calibration Function equation:</p> $y = bx + a$ $b = \frac{\bar{y}}{\bar{x} - z}$ $a = \bar{y} - b\bar{x}$ <p>where  <math>y = \text{CEM}_{\text{calibrate}}</math>  <math>x = \text{CEM}_{\text{measure}}</math>  <math>z = \text{offset; difference between zero reading value } \text{CEM}_{\text{measure}} \text{ and zero}</math></p>

Situation Arise	Procedure to determine calibration function
<p>Situation 3 - A low-level cluster, this occurs when emissions are controlled. A data set is defined as a low-level cluster when the difference between the highest and lowest SRM parallel measurements at standard conditions is less than the maximum permissible uncertainty, and the lowest SRM parallel measurement at standard conditions is less than 15% of the daily ELV.</p> <p><b>(SRM<sub>max</sub> - SRM<sub>min</sub>) &lt; 95%CI of daily average ELV and SRM<sub>min</sub> &lt; 15% of daily average ELV</b></p>	<p>Use procedure C</p> <p>Calibration function not reliable if coefficient of the regression (<math>R^2</math>) <math>R^2 \leq 0.9</math></p> <p>Using surrogates and linearity data to calibrate the CEM. Reference material for this calibration purpose must be certified. Linearity data then used to determine calibration function using Procedure A</p> <p>For particulate PM, if CEMS audit test found that it is not possible to determine a meaningful calibration function (e.g.: most or all of the reported PM values are at or near zero), then</p> <ul style="list-style-type: none"> <li>• Variability test are not necessary to calculate, and</li> <li>• Determine an average and standard deviation for the CEM data and SRM data. If both average lie within the 95% confidence interval of PM dailyaverageELV), the results is acceptable.</li> </ul>

**Table 5.3: Situation arise during parallel measurement and procedure to determine calibration function.**

CEMS	SRM	Approach
NO	NO	Generate a calibration function for NO
NO	Total NO <sub>x</sub>	Generate a calibration function for NO using the measurements for Total NO <sub>x</sub> , bearing in mind that the calibration function should implicitly include the proportion of NO <sub>2</sub> in the stack
NO + NO <sub>2</sub>	Total NO <sub>x</sub>	Convert the NO + NO <sub>2</sub> to total-NO <sub>x</sub> Generate calibration function
Total NO <sub>x</sub>	NO + NO <sub>2</sub>	
NO + NO <sub>2</sub>	NO + NO <sub>2</sub>	

**Table 5.4 – Generating calibration functions for NO<sub>x</sub>**

No	Variability Test	Formula																																																															
1	Standard Deviation of the difference of SRM <sub>std cond</sub> and CEMS <sub>calibrated, std cond</sub> ; S <sub>d</sub>	$S_d = \sqrt{\frac{1}{n-1} \times \sum_{i=1}^n (D_i - \bar{D})^2}$ <p> <i>n</i> = number of measurement  <i>S<sub>d</sub></i> = standard deviation of the difference <i>D<sub>i</sub></i>  <i>D<sub>i</sub></i> = SRM<sub>std cond</sub> - CEMS<sub>calibrated, std cond</sub>  <math>\bar{D}</math> = average of difference </p>																																																															
2	Test of variability	Variability accepted if $S_d < \sigma_o \times k_v$ <p> <i>k<sub>v</sub></i> = test parameter refer to number of parallel measurement; refer to below table  <math>\sigma_o</math> = uncertainty laid down by authorities at 95% CI daily ELV, where <math>\sigma_o</math> </p> $= \frac{\text{daily ELV} - \text{measurement uncertainty; 95\% CI}}{1.96}$ <p>           measurement uncertainty; 95% CI refer to <b>Table 4.1</b> </p> <p><b><i>k<sub>v</sub></i> value table</b></p> <table border="1"> <thead> <tr> <th>Number of parallel measurements <i>N</i></th> <th><i>k<sub>v</sub>(N)</i></th> <th><i>t<sub>0.95(N-1)</sub></i></th> </tr> </thead> <tbody> <tr><td>3</td><td>0.8326</td><td>2.353</td></tr> <tr><td>4</td><td>0.8881</td><td>2.920</td></tr> <tr><td>5</td><td>0.9161</td><td>2.132</td></tr> <tr><td>6</td><td>0.9329</td><td>2.015</td></tr> <tr><td>7</td><td>0.9441</td><td>1.943</td></tr> <tr><td>8</td><td>0.9521</td><td>1.895</td></tr> <tr><td>9</td><td>0.9581</td><td>1.860</td></tr> <tr><td>10</td><td>0.9629</td><td>1.833</td></tr> <tr><td>11</td><td>0.9665</td><td>1.812</td></tr> <tr><td>12</td><td>0.9695</td><td>1.796</td></tr> <tr><td>13</td><td>0.9721</td><td>1.782</td></tr> <tr><td>14</td><td>0.9742</td><td>1.771</td></tr> <tr><td>15</td><td>0.9761</td><td>1.761</td></tr> <tr><td>16</td><td>0.9777</td><td>1.753</td></tr> <tr><td>17</td><td>0.9791</td><td>1.746</td></tr> <tr><td>18</td><td>0.9803</td><td>1.740</td></tr> <tr><td>19</td><td>0.9814</td><td>1.734</td></tr> <tr><td>20</td><td>0.9824</td><td>1.729</td></tr> <tr><td>25</td><td>0.9861</td><td>1.711</td></tr> <tr><td>30</td><td>0.9885</td><td>1.701</td></tr> </tbody> </table>	Number of parallel measurements <i>N</i>	<i>k<sub>v</sub>(N)</i>	<i>t<sub>0.95(N-1)</sub></i>	3	0.8326	2.353	4	0.8881	2.920	5	0.9161	2.132	6	0.9329	2.015	7	0.9441	1.943	8	0.9521	1.895	9	0.9581	1.860	10	0.9629	1.833	11	0.9665	1.812	12	0.9695	1.796	13	0.9721	1.782	14	0.9742	1.771	15	0.9761	1.761	16	0.9777	1.753	17	0.9791	1.746	18	0.9803	1.740	19	0.9814	1.734	20	0.9824	1.729	25	0.9861	1.711	30	0.9885	1.701
Number of parallel measurements <i>N</i>	<i>k<sub>v</sub>(N)</i>	<i>t<sub>0.95(N-1)</sub></i>																																																															
3	0.8326	2.353																																																															
4	0.8881	2.920																																																															
5	0.9161	2.132																																																															
6	0.9329	2.015																																																															
7	0.9441	1.943																																																															
8	0.9521	1.895																																																															
9	0.9581	1.860																																																															
10	0.9629	1.833																																																															
11	0.9665	1.812																																																															
12	0.9695	1.796																																																															
13	0.9721	1.782																																																															
14	0.9742	1.771																																																															
15	0.9761	1.761																																																															
16	0.9777	1.753																																																															
17	0.9791	1.746																																																															
18	0.9803	1.740																																																															
19	0.9814	1.734																																																															
20	0.9824	1.729																																																															
25	0.9861	1.711																																																															
30	0.9885	1.701																																																															

**Table 5.5** - Related variability test equation and criteria

**Figure 5.2 - Flow Chart for Calibration and Variability Test of CEMS**

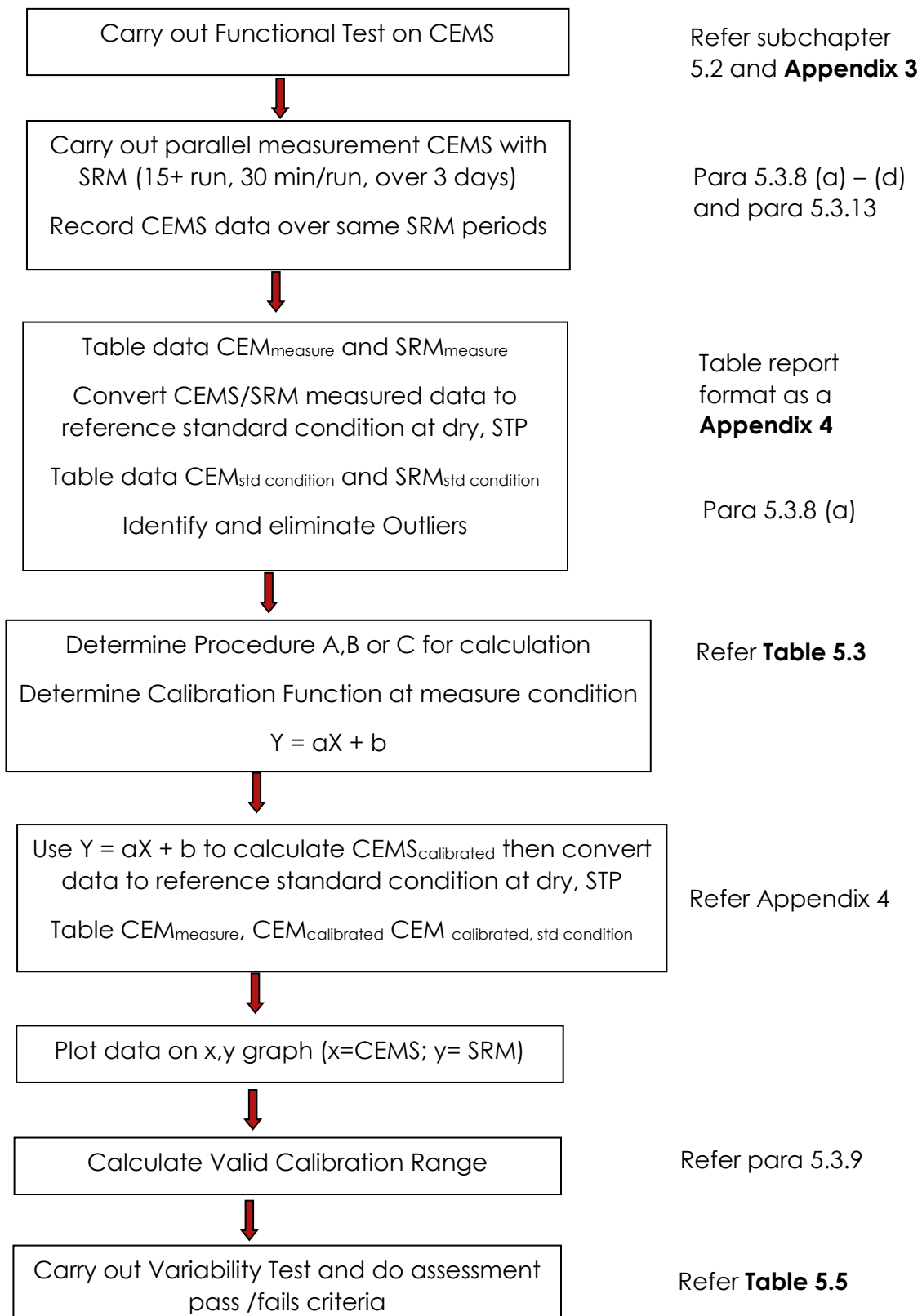

*\*For Annual Surveillance Test – required (5+ run, 30 min/run)*

#### 5.3.13 Standard Reference Method:

- a) DOE recognize the standard methods adopt by USEPA, CEN, ISO or any approved method to be used as Standard Reference Method (SRM) by CEM audit tester. Only approved CEMS audit tester can conduct parallel measurement CEMS with SRM for QAL2-CVT and AST testing.
- b) Monitoring systems used within SRMs must approved by DOE and meet the performance criteria which follow one or more of the international standards below
  - i. United Kingdom Monitoring Certification Scheme (MCERTS) – EN15267-4 & EN14181 QAL1 for Transportable CEMs (T-CEMs)
  - ii. German Technical Inspection and Monitoring Union (TUV) QAL1-EN15267-3 & EN14181 QAL 1 portable AMS (P-AMS)
  - iii. Malaysian Standard MS 2564:2014 - Performance Criteria and Test Procedure For CEMS- Annex F (Transportable System)

#### 5.3.14 Standard Reference Method Measurement Location and Traverse Point:

- a) RM sampling port should be prepared accordingly same as CEMS probe/in-situ location as mention in subchapter 4.2.2. As additional, RM should not interfere with CEM system probe/in-situ location. A distance of 30 cm or 5% of the equivalent diameter of the cross section (whichever less) is specified as an appropriate separation.
- b) For duct or stack less than 2.4 meter diameter, RM testing is performed on a three (3) traverse points; that are 16.7%, 50% and 83.3% of the line as illustrated in **Figure 5.3(a)**.
- c) If duct or stack with measuring line diameter greater than 2.4 meter and stratification is not expected, sampling may conducted at 0.4, 1.2 and 2.0 meter as illustrated in **Figure 5.3(b)**. (This option not allowed after wet scrubbers or where two gas streams with difference pollutant composition combine)
- d) If stratification is expected, the alternative traverse point location, mention in 5.3.5 (c) may not be use and must use three (3) traverse point as mention in 5.3.5 (b) or other traverse points that can be shown and satisfied by DOE base on stratification test.
- e) Conduct all necessary RM test within 3 cm of the traverse points, but no closer than 3 cm to the stack or duct wall.

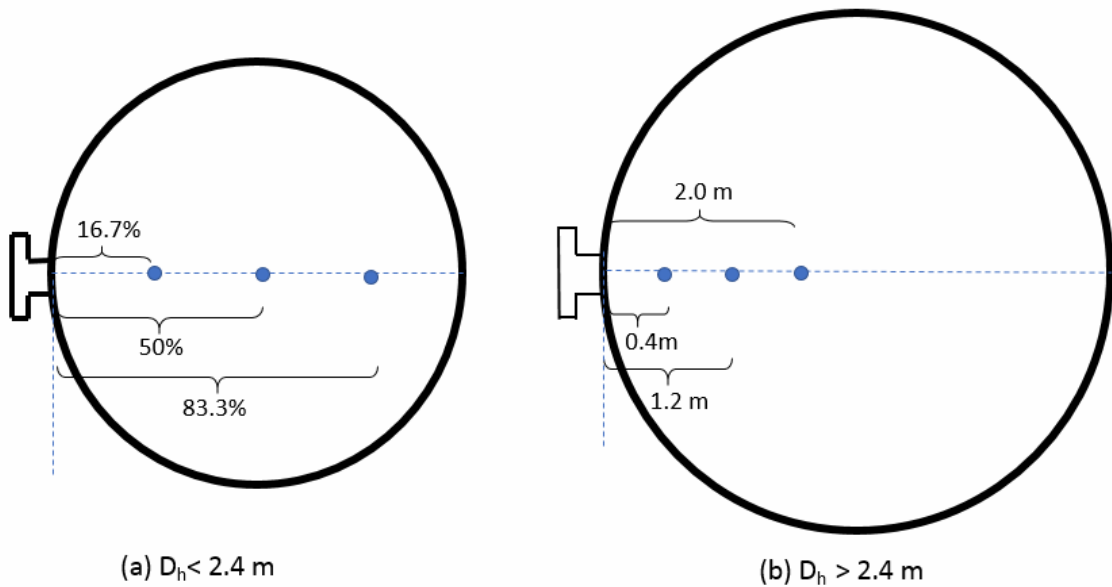

**Figure 5.3 – Reference method traverse points on a measurement line**

#### 5.4 On-Going Performance Monitoring

5.4.1 On-going Performance Monitoring (QAL3-OGPM) procedure are responsibility of plant operator for monitor CEMS during its operation by assessing the drift, response and precision of the instrument. Plant operator shall appoint competence person to conduct QAL3-OGPM of CEMS.

5.4.2 Plant operator requires to ensure that zero and span drift check and response time are carried out periodically based on the maintenance interval. The results shall be recorded and follow the performance criteria as mention in **Table 5.6**

Emission Gases	Performance Characteristic		
	Response Time	Zero Drift	Span Drift
<b>Gases except O<sub>2</sub></b>	< 200 s ( <400 s for HCL & HF)	≤ 3.0 %	≤ 3.0 %
<b>Oxygen; O<sub>2</sub></b>	< 200 s	≤ 0.2 %	≤ 0.2 %
<b>Particulate Matter</b>	< 200 s	≤ 3.0 %	≤ 3.0 %

**Table 5.6: Performance Criteria of Gases and Particulate CEMS**

5.4.3 Zero and span drift check shall be performed using reference materials, such as calibration gases which are traceable to national standards and manufactured recognised by DOE.

5.4.4 Calibration gases should be injected at the sample probe and follow the same path through the CEMS system as the pollutant gas.

5.4.5 Zero and Span Value need to be conducted at two (2) point:

- a) Zero value (between zero to 20% of high-level value) and
- b) Span Value (between 50% to 100% of high-level value)

5.4.6 For particulate CEMS, surrogates for true reference materials will be required for performing zero and span checks, and these should be tested and qualified during the type approval (QAL 1)

5.4.7 Calibration drift is calculated as percentage using the units of reference gas, cell or optical filter and dividing by the span value.

$$\text{CalibrationDrift}(\%) = \frac{\text{reference gas value} - \text{CEMvalue}}{\text{spanvalue}} \times 100$$

5.4.8 As zero and span check measurements are recorded over time a visual representation of the zero and span deviations will develop on the control charts allowing the process operator to assess any potential systematic changes. Zero and span measurements that exceed the alarm limits indicate to the process operator that the CEMS is out of control, and that corrective action is required. (Note: Three (3) commonly used control charts can be used; Shewhart, CUSUM, EWMA. **Figure 5.4 show an example of control chart**)

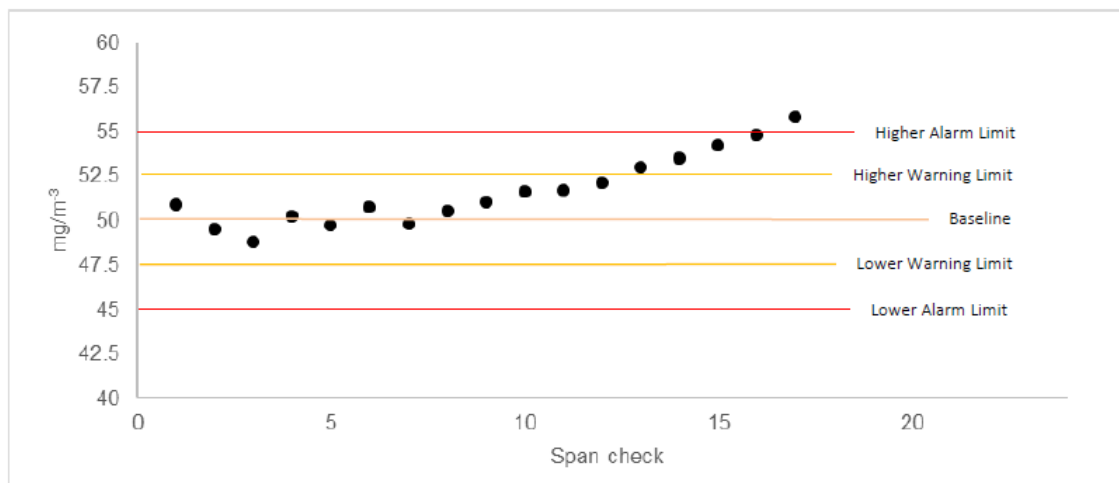

**Figure 5.4 – Example of Control Chart**

5.4.9 The process operator should establish procedures describing what action should be taken when these levels are exceeded.

5.4.10 Zero and span check records along with a history of each time an alarm limit breached, and what corrective action was taken; all must available when the functional test audit is performed before Calibration and Variability Test (QAL2-CVT) or Annual Surveillance Test (AST) is undertaken

## 5.5 Annual Surveillance Test

- 5.5.1 The Annual Surveillance Test shall be carried out yearly, and its purpose is to check that the calibration function of the CEMS is still valid, and that the instrument variability is still within required limits.
- 5.5.2 The tests same as Calibration and Variability Test (QAL2-CVT) described in para 5.3 but with fewer parallel SRM tests.
- 5.5.3 At least five (5) parallel measurements are required, it is advised to carry out at least one more in case a test is deemed as invalid.
- 5.5.4 The time interval between the start of each parallel measurement must be at least one hour.
- 5.5.5 Functional test audit must be performed before conducting AST as described in para 5.2.
- 5.5.6 Determine valid calibration range and carry out variability test; and then do assessment (pass-fail criteria) for variability result. (procedure are same as described in para 5.3.9 and 5.3.10)
- 5.5.7 Same **Figure 5.2** can use to summarize in flow chart for conducting Annual Surveillance Test instead of five (5) parallel measurements of SRM test.
- 5.5.8 The Annual Surveillance Test report shall be prepared submitted to DOE for verification. The test report should be well organized, readable, and complete. All data, including softcopy and hardcopy of raw data necessary to recalculate any of the reportable parameters, should be included in the report. **Appendix 4** listed the items that are to be reported

# Chapter 6 – Reporting

## 6.1 Record Keeping

- 6.1.1 Plant operator must maintain a record of:
- a) All pertinent information, manufacturer literature, phone logs, meeting notes;
  - b) QA Manual containing all QC of CEMS as describe in **Table 5.1**
  - c) Operations and maintenance record;
  - d) Emission measurements, quality assurance test report (Calibration and Variability Test, On-going Performance Monitoring, Annual Surveillance Test etc.
  - e) Excess emission reports, instrument logbooks, downtime, adjustments and maintenance.
- 6.1.2 Record display from DHAS as describe in subchapter 3.4, must made available for audit and inspection.
- 6.1.3 All these records must be retained (softcopy or hardcopy) and made available to DOE for inspection upon request.

## 6.2 Reports

- 6.2.1 Quality Assurance program involve Functional Test, Calibration and Variability Test and Annual Surveillance Test required report to be prepared by CEMS Audit Tester appointed by Plant Operator. These reports shall be submitted to DOE for verification. Format of the report shall follow format given:
- a) **Appendix 3** - Functional Test Audit Report
  - b) **Appendix 4**-Calibration and Variability Test Report / Annual Surveillance Test Report
- 6.2.2 Report of Excesses - in the event where emission limit value standards exceed the prescribed limit values (emission half hour average  $> 2 \times$  ELV and emission daily average  $>$  ELV), plant operator shall notify the DOE within 24 hours of such occurrence.
- 6.2.3 Report of CEMS failure – in the event a CEMS fails to operate, plant operator shall notify DOE not later than one (1) hour.
- 6.2.4 Source shutdown – any operation shutdown due to maintenance schedule, close/stop operation etc. must notify to DOE

- 6.2.5 Report of data not received by iRemote System – as described in subchapter 3.5, data CEMS required transmit to the DOE and will be available view and access by DOE and Plant Operator through Integrated Remote Monitoring System (iRemote). Plant Operator shall aware and notify DOE if the data not transmit to DOE server.
- 6.2.6 iRemote System developed by DOE had a feature to notify plant operator on the schedule of quality assurance program and alert system of any exceed limit. Plant operator shall aware of any notification received through iRemote System and take necessary action to comply the notification received

## Reference

1. Environment Quality Act, 1974
2. Clean Air Regulations, 2014
3. Department of Standard Malaysia, Malaysian Standard MS 2564:2014 - Performance Criteria and Test Procedure For CEMS
4. Department of Standard Malaysia, Malaysian Standard, MS 1596:2003 - Determination of concentration and mass flow of particulate matter in flue gas for stationary source emissions
5. Environment Agency UK, 2018, Technical Guidance Note (Monitoring) - M20 - Quality assurance of continuous emission monitoring systems - application of EN 14181 and BS EN 13284-2
6. Environmental Protection Agency Office of Environmental Enforcement, Ireland, December 2017, Air Guidance Note on the Implementation of I.S. EN 14181
7. Environment Agency UK, 2015, Technical Guidance Note (Monitoring) - M2 - Monitoring of stack emissions to air
8. United States Environment Protection Agency 1990. Continuous Emission Monitoring System; Operation & Maintenance of Gas Monitoring – *APTI Course SI:476B*, Air Pollution Training Institute.
9. United States Environment Protection Agency, Performance Specification 1— Specifications and Test Procedures for SO<sub>2</sub> and NO<sub>X</sub> Continuous Emission Monitoring Systems in Stationary Sources
10. United States Environment Protection Agency, Procedure 1—Quality Assurance Requirements For Gas Continuous Emission Monitoring Systems At Stationary Sources
11. United States Environment Protection Agency, Procedure 2 - Quality Assurance Requirements for Particulate Matter Continuous Emission Monitoring Systems at Stationary Sources

## APPENDIX 1

### CHECK LIST FOR THE APPLICATION AND REGISTRATION OF CONSULTANT FOR CONTINUOUS EMISSION MONITORING SYSTEM (CEMS)

**COMPANY NAME:** \_\_\_\_\_

NO.	CONTENTS	YES(✓) / NO(X)	REMARKS
1	Application Letter & Registration Form		
2	Company Profile		
3	Registration of Company (ROC)		
4	Information on Personnel for CEMS (Appendix A1)		
5	Information on Analyzers and Equipment for CEMS (Appendix A2)		
6	Training Certificate from Manufacturer (Analyzers and Equipment)		
7	Authorized Distributor Letter from Manufacturer (Analyzers and Equipment)		
8	Catalogue, Operating Manual & Specifications on CEMS Analyzers and Equipments		
9	Description for CEMS Analyzer and Equipment on-site Installation & Operation Procedure (Extractive Sampling Method)		
10	CEMS Analyzer and Equipment Schematic Diagram (Extractive Sampling Method)		
11	CEMS International Certification Schemes		
	a. United Kingdom Monitoring Certification Scheme (MCERTS)-EN15267-3 & EN14181		
	b. German Technical Inspection and Monitoring Union (TUV) QAL1-EN15267-3 & EN14181		
12	Quality Assurance and Quality Control Practices (e.g. QC Activities-daily, weekly, monthly, yearly)		
13	Stack Sampling Methodology and Standard Reference Method for dust /gas parameter		

NO.	CONTENTS	YES(✓) / NO(X)	REMARKS
14	Description for Normalized at Standard Condition (STP) and Corrected at Reference Oxygen/Carbon Dioxide (Refer to Table 2 and Table 3, CAR 2014)		
15	Requirements for CEMS Tester / Auditor only		
	a. Mobile/Portable CEMS Certification Schemes (MCERTS/TUV(QAL1)/Performance Specifications Test Report)		
	b. Operating manual and specifications on analyzer & equipment -type/model, function, parameter & range		
	c. Description for CEMS Analyzer and equipment on-site installation & operation procedure		
	d. Schematic diagram showing the analyzer and all the equipment required		
	e. CEMS Audit Procedure-		
	f. Example for CEMS Audit Test Report		
16	Information on CEMS-DIS (Appendix C)		
	a. Computer Hardware & Operating System		
	b. Description process of data collection from CEMS instrument to DOE Server		
	c. Process flow of data collection from CEMS instrument to DOE Server		
	d. Database Management System (DBMS) used		
	e. Table Reading Structure (Refer to item 3.3.8 – data format & data structure, CEMS Guideline Volume II)		
	f. CEMS-DIS Reporting System		
17	Company Working Experiences (Appendix D)		



**APPLICATION FORM FOR THE INSTALLATION  
OF CONTINUOUS EMISSION MONITORING  
SYSTEM (CEMS) AT INDUSTRIAL PREMISES**



**A) INDUSTRIAL DETAILS**

1. Industrial Name
2. Address
3. Plant Location
4. Telephone / Fax No.
5. Plant ID
6. Plant Sector
7. Reasons of CEMS Installation
 

EIA Approval Condition  CAR,2014

DOE Directive  Others  (Please Specify; )
8. Type of Application
 

New Installation  Upgrading/Changes of Plant Operation

Changes of CEMS Equipment  Others  (Please Specify; )
9. Total Stack
10. Contact Person
11. Job Position
12. Email

## B) SOURCE OF EMISSIONS

13. Industrial Process Description Related to the Specified Chimney for this purpose of CEMS installation.

(\*Please attach relevant information and technical drawings as mentioned in Appendix 1 )

14. Source of Emission

- Type of Fuel Burning Equipment/Specified Equipment Related to Specified Chimney (e.g. Boiler, Waste Incinerator, Furnace, Thermal Heater, Turbine etc.)
- Capacity (MW or kg/hr)
- Type of Fuel (gas/solid/liquid)
- Fuel Quantity / Fuel Load (kg/hr)

15. Type of Air Pollutant Monitored

Gases  Particulates/ Dust  Opacity

16. Parameters To Be Monitored. Please Specify :

NO.	PARAMETERS	CONCENTRATION (mg/m <sup>3</sup> )	LIMIT VALUE (mg/m <sup>3</sup> )

Notes : Limit value for each parameter may subjects to the limits mentioned in CAR 2014 and/EIA Approval Condition/DOE Directive

17. Stack Information

- Stack Number
- Stack Height(m/  
mm)
- Stack Diameter (m/mm)
- Upstream:  Downstream:   
(m/mm) (m/mm)

18. Flue Gas Information (During Normal Plant Operation)

- Temperature
- Moisture Content
- Air Flow Rate
- Pressure
- Stack Velocity

19. Written Approval / Notification Status of Fuel Burning Equipment/Specified Equipment (**Please attach complete relevant document**)

Type:

- Date:
- Reference Number:

20. Written Approval / Notification of Air Pollution Control System Information (**Please attach complete relevant document**)

- Type:(e.g. Cyclone, Scrubber, Bag Filter etc):
- Date :
- Reference Number :

**C) INFORMATION OF CEMS EQUIPMENT**

21. Description of CEMS (*Please specify the information of CEMS equipment with relevant catalog or product document*)

- Type

Extractive System  
Source Level   
Dilution

In Situ System  
Point   
Path   
Single Pass   
Double Pass

- Technique/Principal of Detection (e.g. UV Fluorescence, GFC, NDIR, FTIR, DOAS etc):
- Model :
- Certification - (MCERT, TUV - (EN:14181, EN :15267-1, EN :15267-2, EN:15267-3) & Validity Date :

22. Quality Assurance Plan (QAP) for the CEMs Analyzer/Monitor for dust and gas

**D) INFORMATION OF CEMS DATA COMMUNICATION**

- 23. Connectivity Type
- 24. Domain Name / I.P No
- 25. TCP Port No.
- 26. Phone Number
- 27. User ID
- 28. Password

**E) INFORMATION OF CEMS PERSONEL**

- 29. Name
- 30. Position
- 31. Email
- 32. Certification
- 33. CEMS Relevant Training Information

**F) INFORMATION OF CEMS SUPPLIER / PROVIDER**

- 34 Name of Company
- 35. Address & Email
- 36. Person Incharge & Contact No.
- 37. DOE CEMS Registration Status
- 38. Date of Registration
- 39. Supplier Type:

Sole/main Supplier

Distributor/Appointed Agent

*I ..... the owner/ occupier/ authorized consultant of the owner/occupier, hereby declare that all the information given in this application is to the best of my knowledge and belief true and correct.*

\_\_\_\_\_  
Signature

Company's Seal

- Name :
- NRIC No. :
- Position :
- Date :

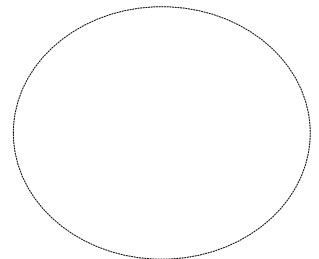

## APPENDIX 1

Relevant information and technical drawings need to be attached with application during submission:

a) **Process flow chart** - overall industrial process flow cart that showing the sequence of each process including all fuel burning equipment, all air pollution control and all stack location;

b) **Layout plan of industrial premises** showing CEMS location;

c) **Technical drawing of stack and CEMS measurement location.** Drawing must contain information below

- i. Overall stack design (side view & top view from upstream to downstream);
- ii. Stack height;
- iii. Stack downstream height;
- iv. Stack upstream height;
- v. Flue gas ducting to stack height;
- vi. Sampling platform height from ground level;
- vii. Sampling port height for dust & gas;
- viii. Reference method sampling port height for dust & gas;
- ix. Internal stack diameter & thickness;
- x. Sample probe insertion length;
- xi. Flange length;
- xii. Sampling port point diagram that showing the side view and top view sampling location for (dust & gas) and reference method.

Note : All unit dimension in meter or millimeter

Recycle old drawing from any previous project are not allowed.

Only relevant information to justify the suitability of measurement location are included in the drawing.

d). **Piping and Instruments Diagram (P&ID) of CEMS equipment installation for Extractive Sampling Method** [stack location - heated sample probe - heated line - heated pump - temperature controller - gas conditioning - flow meter - analyser - zero & span calibration gas (mention the specific gases are required and also the technique required for the certain gases, e.g HCL, HF ) - Purging/blow back & purge air unit/instrument air tubing line for dust/gas - Data Acquisition System - Data Information System] etc.

e) **Schematic Diagram of CEMS equipment installation for In-Situ Sampling Method** (stack location - analyzer - zero & span calibration - Purging/blow back & purge air unit/instrument air tubing line for dust/gas - Data Acquisition System - Data Information System) etc.

f) CEM consultants / suppliers or applicants should provide evidence of data obtained from CEMS equipment in compliance with these valid averages.

**Important Note:**

***\*All technical drawing must have reference number, title and endorsement of applicant and CEMS consultant and submit in A1/A2 paper size***

### Functional Test Audit Guidance

A functional test audit shall be performed on the complete CEMS sampling train before a Calibration & Variability Test (QAL2-CVT) or Annual Surveillance Test (AST) is performed, in order to confirm that it has been installed correctly and is working as expected. This will involve assessing the installation of the CEMS, its response to reference materials, as well as checking the On-Going Performance Monitoring process and all other relevant documentation.

The functional test audit shall be performed **no more than one (1) month** before the parallel measurements are started and will be carried out in a separate visit to the QAL2-CVT/AST. This is to ensure that any faults or problems that are discovered can be corrected in time. It is required to include peripheral CEMS of Oxygen and Moisture (if used) in these audits, as measurements from these systems are used to correct to standardized conditions.

The following guidance is provided to help perform the functional test audit, and a format report is included. Not all sections need to be completed; the table below indicates which steps need to be completed, depending on what type of CEMS is being audited.

**Table 1: Functional Test Audit Requirements**

Functional test activity	Calibration & Variability Test (QAL2-CVT) & Annual Surveillance Test (AST)	
	Extractive CEMS	In-Situ CEMS
Alignment & cleanliness		/
Sampling Train	/	
Documentation and records	/	/
Serviceability	/	/
Leak Test	/	
Zero and span check	/	/
Linearity	/	
Interferences	/	/
Zero and span drift (audit on On-Going Performance Monitoring)	/	/
Response time	/	/
Report	/	/

### Measurement Site & Installation

A risk assessment of the work area is required prior to starting the functional test audit, and checks shall be undertaken to ensure that there are suitable provisions to carry out the functional test audit and parallel measurements later. The CEMS should have weather protection as well as enough space and safe access to perform the necessary

work. Suitable tools, reference materials, and spare parts shall also be readily accessible.

### **Alignment & Cleanliness**

A visual inspection of the CEMS shall be carried out. This will involve checking of the internal components, assessing the amount of contamination, and checking the alignment of the system amongst other things.

### **Sampling Train**

A visual inspection of the CEMS sampling train shall be carried out by the instrument engineer or test laboratory. This will involve checking each component of the sampling train, confirming that they are working correctly, and are in good condition.

### **Leak Test**

A leak test of the complete sampling train is required and shall be performed in accordance with the CEMS manual.

### **Zero & Span Checks**

Appropriate zero and span reference materials shall be used to check the response of the CEMS. In-situ CEMS will require a reference path free of flue gas, which may require the removal of the instrument from the stack. It shall be confirmed that the CEMS reads zero when a zero concentration is applied.

### **Response Time**

The response time of the complete sampling train shall be assessed. Each species under test shall meet the requirement set for Calibration & Variability Test (QAL2-CVT)

### **Linearity**

A linearity test shall be performed on the CEMS across a range that as a minimum covers the short term ELV. The linearity will be checked using five concentrations, which includes zero, spread equally across the range using suitable reference materials.

If reference gases are used these must be traceable to approved standards. Either separate gas cylinders can be used to achieve the required concentrations, or a single gas cylinder can be used to blend to the relevant concentration using a calibrated dilution system. Some CEMS cannot use reference gases and will require suitable surrogate reference material that have been verified to perform the linearity e.g. particulate CEMS.

The linearity will be performed in a randomized order using concentrations at zero (twice) and approximately 20%, 40%, 60% and 80% of the range. For each change in concentration the first instrument reading shall be taken after a time period of at least three response times. Three readings will be taken at each concentration, and these readings will be separated by a time period of at least four response times. A reduced time may be taken between readings in order to reduce the time taken for the tests, however if this results in a failure the test shall be repeated using the standard approach.

The linearity test results shall be calculated using the procedure outlined in Annex C - Malaysian Standard MS 2564:2014 - Performance Criteria and Test Procedure For CEMS

### **Interferences**

If there are any components in the stack gas that have been identified as interferences during the QAL2-CVT process, an interference test shall be undertaken.

### **On Going Performance Monitoring**

An audit of the process operators QAL3 records shall be undertaken. The assessment shall verify that suitable control charts are in place which include the results from zero and span checks undertaken since the last functional test audit, as well as a record of all alarm limit exceedence, and what action was taken to correct this.

### **Documentation**

The CEMS audit tester shall check that the process operator has all the required documentation such as records keeping and records mention Chapter 6 of guidelines are in place or readily available.

### **Report**

If any faults or problems have been identified, these should be noted, and the required corrective action undertaken. Photos of all functional test activities shall include in reports.

## Functional Test Audit Report Format

<b>Plant Operator &amp; Address:</b>	<b>Type of Process:</b>
<b>Contact Person:</b> Name: Address E-mail: Contact No:	<b>Installation Name:</b>
<b>Dates of Functional Test:</b>	<b>DOE Letter Reference No/Date:</b> (written approval/notification of installation, CEMS approval notification, EIA approval or license permit approval (if any))
<b>Report Date:</b>	<b>Report By:</b> (name shall certified/approved by DOE) Name: Address E-mail: Contact No:

CEMS Information				
CEMS Manufacturer and Model				
Serial Number				
Certified No				
Emission Pollutant	Measured Unit	Measured Range	Measured Conditions	Current Calibration Function
Measurement Site & Installation				
(Note: An assessment of the installation shall be undertaken to check that there is a safe working environment and that there are suitable provisions in place)				

<b>In-stu&amp; Extractive CEMS</b>	<b>Check (/) or (x)</b>	<b>Notes</b>
Is there a safe and clean working environment that has enough space and weather protection?		
Is there easy and safe access to the AMS?		
Are tools, spares parts and reference materials available?		
Are there facilities to introduce reference materials directly to the AMS as well as through the complete system (extractive only)?		
<b>Alignment &amp; Cleanliness</b>		
The complete sampling train shall be visually inspected to check the alignment and cleanliness of the system		
<b>In-Situ CEMS</b>	<b>Check (/) or (x)</b>	<b>Notes</b>
Internal check of the CEMS components		
Cleanliness of the optical		
Flushing of air supply Any obstructions in the optical path		
The following shall be checked after the CEMS has been re-assembled and installed at the sampling location		
Alignment of the measuring systems		
Contamination control (internal check of optical surfaces)		
Flushing air supply		

<b>Extractive CEMS</b>	<b>Check (/) or (x)</b>	<b>Notes</b> (The complete sampling train shall be visually inspected)
Sampling probe		
Gas conditioning systems		
Pumps		
All connections		
Sample lines		
Power supplies		
Filters		
NOx converter efficiency (if applicable)		
Visual inspection of sampling train		
<b>Leak Test</b> (The complete system shall be leak tested in accordance with the CEMS manual)		
<b>Extractive CEMS</b>	<b>Check (/) or (x)</b>	<b>Notes</b>
Leak Test Results (attach here)		
<b>Zero &amp; Span Check</b> (Verify the zero and span of the CEMS using suitable reference materials. For in-situ CEMS a reference path free of flue gas is required)		
<b>In-situ-Extractive CEMS</b>	<b>Check (/) or (x)</b>	<b>Notes</b>
Zero Check		
Span Check		
<b>Response Time</b> (The response time of the CEMS shall be checked through the complete sampling train, this shall not exceed the criterion specified in performance specification criteria certified for this equipment)		
<b>In-situ &amp; Extractive CEMS</b>	<b>Check (/) or (x)</b>	<b>Notes</b>
Response Time		
<b>Linearity</b> The CEMS is tested using five (5) reference concentrations including a zero, at the inlet of the analyser, the concentrations shall be spread over a range of at least the short term		

ELV and applied in a random order		
<b>In-situ &amp; Extractive CEMS</b>	<b>Check (/) or (x)</b>	<b>Notes</b>
What reference materials will be used to perform the linearity?		
Reference material information (e.g. cylinder IDs, dilution system ID, reference filter IDs)		
Reference material with zero concentration		
Reference material concentration approximately 20% of the range		
Reference material concentration approximately 40% of the range		
Reference material concentration approximately 60% of the range		
Reference material concentration approximately 80% of the range		
Reference material with zero concentration		
Does the CEMS pass? (The procedure is described Annex C MS 2564:2014)		(Results table and calculation must attach)
<b>Interference</b>		
Tests shall be undertaken if there are interferents in the flue gas that could influence the CEMS. These will have been identified during the QAL 1 certification process		
<b>In-situ &amp; Extractive CEMS</b>	<b>Check (/) or (x)</b>	<b>Notes</b>
Has an interference check been carried out?		

<b>Zero &amp; Span Drift Audit</b>		
On-Going Performance Monitoring (on maintenance interval) shall be carried out in order to check that there is a procedure in place, regular zero and span measurements are being performed and that what action was taken if a On-Going Performance Monitoring failed		
<b>In-situ &amp; Extractive CEMS</b>	<b>Check (/) or (x)</b>	<b>Notes</b>
Has a check of the On-Going Performance Monitoring audit been performed?		(attach control chart, corrective action taken )
<b>Documentation</b>		
The process operator should have access to the following records and documents		
<b>In-situ &amp; Extractive CEMS</b>	<b>Check (/) or (x)</b>	<b>Notes</b>
A plan of the CEMS		(show probe/in-situ installation, schematic diagram, sampling train approved by DOE)
CEMS certification information		
QA Manuals		
Log Books (Detailing problems with the CEMS and corrective action taken)		
Service Reports		
On-Going Performance Monitoring Documentation		
Procedures for CEMS maintenance, calibration and training		
Training Records		
Maintenance Schedules		
Auditing plans and records		
<b>Report</b>		
The functional test audit shall be completed before the QAL2-CVT/ASTin case any corrective action is required		
<b>In-situ &amp; Extractive CEMS</b>	<b>Check (/) or (x)</b>	<b>Notes</b>
Are there any faults that require corrective action?		

<b>Personnel Involved with the Functional Test Audit</b>			
<b>Name</b>	<b>Company</b>	<b>Date</b>	<b>Role</b>

### Calibration & Variability Test/Annual Surveillance Test Guidance

This report format template specifies the minimum requirements for reports for Calibration & Variability Test (QAL2-CVT) and Annual Surveillance Test (AST), as required by DOE in this guideline. It is a specification for both the contents of a report, and the order of the contents. This means that every single item included in this template must be included in the test reports for QAL2-CVT and AST. We may reject any test reports that do not comply with these requirements. CEMS Tester may include additional information, and also present much of the information specified below within tables. However, additional information should be within the annexes, in order to keep the main body of the report as short as possible. The full data and supplementary information should be included in annexes.

The template is based on Microsoft Word but a CEMS tester can use any type of software provided that the minimum requirements set out in this template are included. The softcopy of raw data (Microsoft Excel format) shall be submitted together with hardcopy of this report to DOE

DOE may require additional information in order to verify that the procedure has been follow.

This format report template is divided into six (6) core sections and supporting Annexes, which are:

- a) Section 1 – Title Page/Executive summary;
- b) Section 2 – Information about the regulated installation, and its provisions for monitoring;
- c) Section 3 – Information about the monitoring that the test laboratory performs
- d) Section 4A – Data and calculations – QAL2;
- e) Section 4B – Date and calculations – AST;
- f) Section 5 – Results of the functional tests, and who performed the tests.
- g) Annexes
  - Any supporting data which the CEMS tester decides to include in the annexes;
  - Any supporting information about the CEMS tester, e.g. a copy of the scope of accreditation.

## Calibration & Variability Test/Annual Surveillance Test - Report Format

### Section 1

<b>Title Page</b> (QAL2-CVT or AST)	
<b>Plant Operator &amp; Address:</b>	<b>Type of Process:</b>
<b>Contact Person:</b> Name: Address E-mail: Contact No:	<b>Installation Name:</b>
<b>Dates of Tests/Sampling:</b> -CEMS Functional Checks: -Linearity Test: -Parallel Measurement SRM:	<b>DOE Letter Reference No/Date:</b> (written approval/notification of installation, CEMS approval notification, EIA approval or license permit approval (if any))
<b>Report Date:</b>	<b>Report By:</b> (name shall certified/approved by DOE) Name: Address E-mail: Contact No:

**Executive Summary**

(shall contain following summarize information & results)

- Whether the test is an AST or a QAL2;
- The stack designation;
- The emission substance;
- Value for a in the calibration function;
- Value for b in the calibration function;
- The valid calibration range based on calibrated CEMs data from the QAL2-CVT;
- The valid calibration range based on calibrated CEMs data from the AST;
- The extrapolated range based on reference materials;
- A statement of a pass or fail for the variability test (QAL2-CVT and AST);
- A statement of a pass or fail for the calibration test (AST);
- Recommendations where applicable;
- A firm statement that the calibration function, once applied, only remains valid if the On-Going Performance Monitoring data remains within control limits, and that there are no manual adjustments made to the CEMs other than those allowed to bring the settings back within the OGPM control limits.

Example Result Table:

Parameter	Calibration Function	Procedure used (a or b)	Valid Calibration Range at Ref Condition	Calibration Function Derived from Linearity (Y or N)	Assessment of Variability Test	95% Confidence Interval Requirement	Difference $CEM_{measure}$ before calibration - $SRM_{measure} < 95\% CI$ Yes/No

**Deviations**

- If there any are deviations from the SRMs, and reasons for this;
- If there any are deviations from QAL1 - certification, and reasons for this;
- Any impacts on the results;
- Any actions required.

## Section 2

Information about the Regulated Installation			
<b>2.1 Regulatory Information</b>			
<b>2.1.1 Name of the Installation</b>			
<b>2.1.2 Address of the Installation</b>			
<b>2.1.3 Activity</b> (as refer to schedule 2 and 3 of CAR 2014)			
<b>2.1.4 Date of Last QAL2-CVT/AST</b>			
<b>2.1.5 Regulated emission substance and ELV</b>			
Emission substance	Daily ELV	½ hour ELV	Required Uncertainty <i>(This will be expressed as a 95% confidence interval)</i>
<b>2.2 Operational Information and site monitoring-provisions</b>			
<b>2.2.1 Process type and variations in emissions.</b>			
<ul style="list-style-type: none"> <li>• Continuous or batch process - describe the operating phases. Indicate the percentage of the load of normal runs and expected variations of emissions;</li> <li>• Explain how the expected emissions and variations in the emissions influence the sampling times and duration, in order to capture a representative set of samples;</li> <li>• Include any other factors which would affect the monitoring results e.g. automatic zero and span operations, or low-emissions values;</li> <li>• It is also essential to check historical data beforehand, to check if the emissions are at or near zero and to report these;</li> <li>• If the check reveals that the emissions are at or near zero, then include provisions to deal with these low emissions;</li> <li>• If the CEM is reading zero, then investigate to ensure that the CEM is working. An agreement with the client that the implications are understood and that these discussions and findings are documented.</li> </ul>			
<b>2.2.2 Type of Fuel</b>			
<ul style="list-style-type: none"> <li>• Describe the types of fuels and their proportions used during the QAL2-CVT/AST, and during a normal operating year; also whether multiple calibration-functions are required;</li> <li>• If the process is co-incineration, then what types and proportions of fuels were used?</li> </ul>			
<b>2.2.3 Abatement</b>			
Type of abatement plant and how this affects emissions.			

## 2.3 Monitoring provisions at the installation – periodic monitoring

### 2.3.1 Stack and Sampling ports

#### a) Stack/Duct Characteristic

	Value	Units
Shape		
Diameter		
Stack Height		
Height/Length of sampling location from downstream		
Height/Length of sampling location from upstream		

#### b) Sampling Lines & Sample Point

	Particulate	Gases
Sample Port Size		
Number Used		
Orientation		
Number Points/Lines		
Filtration Location		

### 2.3.2 Monitoring Platform and site provision

#### a) Access Sampling Platform Information

	Observation
Type	
Safe & clean working environment	
Sufficient whether protection	
Do site hold suitable tools	
Do site stock sparepart	
Can ref gases be injected at inlet & probe?	

- Include a diagram (and preferably latest/current photographs) of the emission point, platform and location.

### 2.3.3 Sample – how representative is it?

Homogeneity assessment and stratification test finding. Include this assessment in this report

**2.4 Continuous Emission Monitoring Systems (CEMs) at the installations****2.4.1 Types of CEMS for each main pollutant, oxygen and moisture**

Pollutant (including O <sub>2</sub> and moisture)	Type of CEMS	CEM Supplier / Manufacturer	Instrument Model	Minimum Certification Range	Actual Measure Range	Measurement Technique	QAL1 Certificate No

**2.4.2 Types of monitoring for peripheral determinants**

Monitoring for temperature and pressure, and a statement whether temperature and pressure are recorded.

**2.4.3 Site Reference Material**

Provide information of pollutant, supplier, concentration range, date of manufacturer and expiration. Certificate shall attach

### Section 3

Information about the monitoring campaign							
<b>3.1 Stack Emission Monitoring team</b>							
Table all the name, position, years of experience all individual involve in SRM							
<b>3.2 Standard Reference Methods (SRM)</b>							
<b>3.2.1 SRM Equipment</b>							
Pollutant	SRM System Provider	Instrument Model	Measurement Technique	QAL1 Certificate Number	Minimum Certified Range	Operating Range	Measurement of un certainty as 95% CI Daily Average
<b>3.2.2 Sampling Method with Subsequent Analysis</b>							
Pollutant		Standard Method		Accreditation		Laboratory	
<b>3.2.3 On-Site Testing</b>							
Pollutant		Standard Method		Accreditation		Laboratory	

## Section 4A – Data and calculation for Calibration & Variability Testing (QAL2-CVT)

<b>Section 4A – Monitoring data and calculations</b>	
<p>This section specifies the minimum number of tables and charts, and the minimum requirements for each table. CEMS Audit Tester may combine tables where data would be repeated, e.g. in Table 4.1 and 4.2, where it is necessary to convert data to standard conditions in order to determine the procedure to be used.</p>	
<b>A4.1</b>	<p><b>Table 4.1 - Raw monitoring data</b></p> <ul style="list-style-type: none"> <li>• Start and end times of each pair of data;</li> <li>• Raw CEM results;</li> <li>• Stack/CEM peripheral determinants for temperature, pressure, oxygen and moisture (if measured);</li> <li>• Raw SRM results;</li> <li>• SRM peripheral determinants for temperature, pressure, oxygen and moisture;</li> <li>• SRM results expressed under the same conditions as the CEM results.</li> </ul>
<b>A4.2</b>	<p><b>Table 4.2 – Standardised Monitoring data</b></p> <ul style="list-style-type: none"> <li>• Standardised CEM results (i.e. STP, dry and to the reference O<sub>2</sub> concentration);</li> <li>• Standardised SRM results (i.e. STP, dry and to the reference O<sub>2</sub> concentration).</li> </ul>
<b>A4.3</b>	<p><b>Plot 1 – mandatory</b></p> <p>Time series of standardized CEM versus standardized SRM data.</p>
<b>A4.4</b>	<p><b>Calculation and procedure – Elimination of outliers</b></p> <p>Outliers should be clearly indicated in the averaged raw-data set.</p>
<b>A4.5</b>	<p><b>Calculation – determination of Procedure a, b or c</b></p> <p>Justify your procedure</p>
<b>A4.6</b>	<p><b>Table 4.3 – data used to determine the calibration function</b></p> <ul style="list-style-type: none"> <li>• SRM results expressed under the same conditions as the CEM results</li> <li>• Raw CEM results</li> </ul>
<b>A4.7</b>	<p><b>Calculation – determination of the calibration function</b></p> <p>show 1 example base from the Table 4.3</p>
<b>A4.8</b>	<p><b>Table 4.4 – Calculation of calibrated CEM values</b></p> <ul style="list-style-type: none"> <li>• Raw CEM values;</li> <li>• Calibrated CEM values, at CEM conditions;</li> <li>• Peripheral determinants for CEMs;</li> <li>• Calibrated CEM values, standardized.</li> </ul>

<b>A4.9</b>	<p><b>Plot 2 – mandatory</b></p> <ul style="list-style-type: none"> <li>• x-y plot of CEM versus SRM data, both at conditions measured by the CEM, and not standardized;</li> <li>• Calibration function, including R2 value.</li> </ul>
<b>A4.10</b>	<p><b>Table 4.5 – Data used for the variability test</b></p> <ul style="list-style-type: none"> <li>• Calibrated CEM values, standardized;</li> <li>• SRM values, standardized;</li> <li>• Difference between each pair of values;</li> <li>• Difference minus the average of the differences;</li> <li>• Difference minus the average of the differences, squared.</li> </ul>
<b>A4.11</b>	<p><b>Calculation - the variability test</b></p> <ul style="list-style-type: none"> <li>• The calculations, as set out in EN 14181;</li> <li>• The variability test;</li> <li>• Statement of the results.</li> </ul>
<b>A4.12</b>	<p><b>Plot 3 – Mandatory</b></p> <ul style="list-style-type: none"> <li>• x-y plot of calibrated, standardized CEM data versus standardised SRM data;</li> <li>• Indication of the valid calibration range;</li> <li>• Extrapolation of the valid calibration range, using surrogates;</li> <li>• Parallel lines above and below the regression line through the standardised, calibrated CEM values and standardised SRM values. The parallel lines should indicate the derived uncertainty (<math>\sigma</math>) of the allowable 95% confidence interval of the daily average ELV (sometimes called 'tramlines').</li> </ul>

## Section 4B – Data and calculation for Annual Surveillance Test (AST)

<b>Section 4B – Monitoring data and calculations</b>	
This section specifies the minimum number of tables and charts, and the minimum requirements for each table. CEMS Audit Tester may combine tables where data would be repeated.	
<b>B4.1</b>	<p><b>Table 4.1 - Raw monitoring data</b></p> <ul style="list-style-type: none"> <li>• Start and end times of each pair of data;</li> <li>• Raw CEM results;</li> <li>• Stack/CEM peripheral determinants for temperature, pressure, oxygen and moisture (if measured);</li> <li>• Raw SRM results;</li> <li>• SRM peripheral determinants for temperature, pressure, oxygen and moisture;</li> <li>• SRM results expressed under the same conditions as the CEM results.</li> </ul>
<b>B4.2</b>	<p><b>Table 4.2 – Standardised Monitoring data</b></p> <ul style="list-style-type: none"> <li>• Standardised CEM results (i.e. STP, dry and to the reference O<sub>2</sub> concentration);</li> <li>• Standardised SRM results (i.e. STP, dry and to the reference O<sub>2</sub> concentration).</li> </ul>
<b>B4.3</b>	<p><b>Plot 1 – mandatory</b></p> <p>Time series of standardized CEM versus standardized SRM data.</p>
<b>B4.4</b>	<p><b>Calculation and procedure – Elimination of outliers</b></p> <p>Outliers should be clearly indicated in the averaged raw-data set.</p>
<b>B4.5</b>	<p><b>Table 4.3 – data used to calculate the calibration function</b></p> <ul style="list-style-type: none"> <li>• Raw CEM values;</li> <li>• The original calibration function from the previous QAL2;</li> <li>• Calibrated CEM values, at CEM conditions;</li> <li>• Peripheral determinants for CEMs;</li> <li>• Calibrated CEM values, standardized;</li> <li>• Standardized SRM values.</li> </ul>
<b>B4.6</b>	<p><b>Table 4.4 – Data used for the variability test</b></p> <ul style="list-style-type: none"> <li>• Calibrated CEM values, standardized;</li> <li>• SRM values, standardized;</li> <li>• Difference between each pair of values;</li> <li>• Difference minus the average of the differences;</li> <li>• Difference minus the average of the differences, squared.</li> </ul>

<b>B4.7</b>	<b>Calculation - the variability test &amp; acceptance test</b> <ul style="list-style-type: none"> <li>• The calculations, as set out in EN 14181;</li> <li>• The variability test;</li> <li>• The acceptance test;</li> <li>• Statement of the results.</li> </ul>
<b>B4.8</b>	<b>Plot 2 – Mandatory</b> <ul style="list-style-type: none"> <li>• x-y plot of calibrated, standardised CEM data versus standardised SRM data;</li> <li>• Indication of the valid calibration range;</li> <li>• Parallel lines above and below the regression line through the calibrated, standardised CEM values and standardised SRM values. The parallel lines should <ul style="list-style-type: none"> <li>• Air Guidance Note on the Implementation of I.S. EN 14181 (AG3)</li> <li>• Page 57 of 57</li> </ul> </li> <li>• indicate the derived uncertainty (<math>\sigma</math>) of the allowable 95% confidence interval of the daily average ELV (sometimes called 'tramlines');</li> <li>• Extrapolation of the valid calibration range, using surrogates, if applied.</li> </ul>

### Section 5 – Results of the functional tests

<b>5.1</b>	<b>Results of functional tests</b> Attach functional test report; format as Appendix 3
------------	---

### Section 6 – Personnel Involve

<b>Personnel Involved with Calibration &amp; Variability Test/Annual Surveillance Test</b> List all the name involve in the CVT/AST and their roles			
Name	Position/ Company	Date	Role