

AIR POLLUTION

M N RAO
H V N RAO





Tata McGraw-Hill

Copyright © 1989, by Tata McGraw-Hill Publishing Company Limited.

26th reprint 2007
RZLBCDLKRCLRC

No part of this publication may be reproduced or distributed in any form or by any means, electronic, mechanical, photocopying, recording, or otherwise or stored in a database or retrieval system without the prior written permission of the publishers. The program listings (if any) may be entered, stored and executed in a computer system, but they may not be reproduced for publication.

This edition can be exported from India only by the publishers,
Tata McGraw-Hill Publishing Company Limited.

ISBN 0-07-451871-8

Published by the Tata McGraw-Hill Publishing Company Limited,
7 West Patel Nagar, New Delhi 110 008, and printed at
Sai Printo Pack Pvt. Ltd., A 102/4 Okhla Indl. Area, Phase II, New Delhi 110 020.

The McGraw-Hill Companies

Contents

<i>Preface</i>	v
<i>Acknowledgements</i>	vi
1. Introduction	1
2. Sources and Classification of Air Pollutants	4
3. Meteorology and Air Pollution	14
4. Industrial Plant Location and City Planning	37
5. Effects of Air Pollution on Human Health	43
6. Effects of Air Pollution on Animals	56
7. Effects of Air Pollution on Plants	61
8. Economic Effects of Air Pollution	70
9. Sampling Procedures	81
10. Analytical Methods	120
11. Air Pollution Due to Automobiles	131
12. Photochemical Air Pollution	148
13. Control of Air Pollution by Equipment	152
14. Smoke and Its Control	195
15. Control of Gaseous Contaminants	202
16. Odours and Their Control	207
17. Control of Air Pollution by Process Changes	215
18. Air Pollution from Major Industrial Operations	221
19. Air Quality and Emission Standards	255
20. Air Pollution Indices	269
21. Air Pollution Survey	276
22. Air Pollution Legislation and Regulations	285
23. Air Pollution in Indian Cities	298
24. Miscellaneous Current Topics	307
<i>References</i>	315
<i>Appendices</i>	325
<i>Index</i>	335

1

Introduction

The atmosphere, which makes up the largest fraction of the biosphere, is a dynamic system that continuously absorbs a wide range of solids, liquids, and gases from both natural and man-made sources. These substances travel through air, disperse, and react with one another and with other substances both physically and chemically. Most of these constituents, eventually find their way into a depository such as the ocean, or to a receptor such as man. Some substances such as helium, however, escape from the biosphere. Others such as carbon dioxide, may enter the atmosphere faster than they enter a reservoir and thus gradually accumulate in the air.

Clean, dry air contains 78.09% nitrogen by volume and 20.94% oxygen. The remaining 0.97% is composed of a gaseous mixture of carbon dioxide, helium, argon, krypton, nitrous oxide and xenon, as well as very small amounts of some other organic and inorganic gases whose amount in the atmosphere vary with time and place. Various amounts of contaminants continuously enter the atmosphere through both natural and man-made processes that exist upon the earth. That portion of these substances which interacts with the environment to cause toxicity, disease, aesthetic distress, physiological effects or environmental decay, has been labelled by man as a 'pollutant'.

In general, the actions of people are the primary cause of pollution and as the population increases, the attendant pollution problems also increase proportionately. The first significant change in man's effect on nature came with his discovery of fire. Prehistoric man built a fire in his cave for cooking, heating, and to provide light. The problem of air pollution came into existence at this time.

The British Parliament passed an Act in 1273, forbidding the burning of coal in London because it was beginning to choke the atmosphere. In 1300, King Edward I issued a royal proclamation, "Whosoever shall be found guilty of burning coal shall suffer the loss of his head." In 1306, a man was executed for violating this regulation. Later, the law fell into disuse as the industrial revolution took place in England.

Air pollution is basically the presence of foreign substances in air. Some specific definitions of air pollution are given below.

"Air pollution means the presence in the outdoor atmosphere of one or more contaminants, such as dust, fumes, gas, mist, odour, smoke, or vapour, in quantities, with characteristics, and of durations such as to be injurious to human, plant,

2 Air Pollution

or animal life or to property, or which unreasonably interfere with the comfortable enjoyment of life and property.”

—Engineers Joint Council (U.S.A.)

“Air pollution is the presence in ambient atmosphere of substances, generally resulting from the activity of man, in sufficient concentration, present for a sufficient time and under circumstances which interfere significantly with the comfort, health or welfare of persons or with the full use or enjoyment of property.”

—Indian Standards Institution IS-4167 (1966).

“Air pollution is the excessive concentration of foreign matter in the air which adversely affects the well being of the individual or causes damage to property.”

—American Medical Association

Since air pollution has been mainly caused by rapid industrialisation in some western countries, some critics comment on air pollution as ‘the price of industrialisation’. Air pollution caused by automobiles has been described as the ‘disease of wealth’.

Air pollution means different things to different people. To the householder it may be an eye irritation and soiled clothing, to the farmer damaged vegetation, to the pilot dangerously reduced visibility and to industries problems of process control and public relations.

Further, the problem of air pollution varies from place to place. For example, air pollution in Tokyo is not the same as that in Bombay.

Today, the natural terrain that surrounds large cities is recognised as having a significant bearing on the problem of air pollution. However, this is not an altogether new concept either. Historians tell us that Los Angeles which in recent years has become a national symbol of comparison for excessive smog levels, was known as the ‘valley of smokes’ when the Spaniards first arrived there.

It has been found that a significantly increasing volume of particulate matter entering the atmosphere, scatters the incoming sunlight. This reduces the amount of heat that reaches the earth and tends to reduce its temperature. The decreasing mean global temperature of recent years has been attributed to the rising concentration of air-borne particles in the atmosphere. A counter acting phenomenon commonly referred to as the “greenhouse effect” is caused by the increasing amounts of carbon dioxide found in the atmosphere. It has been estimated that if the carbon dioxide content in the atmosphere generated in combustion processes continues to increase at the present rate, the mean global temperature could rise by 4°C in the next five decades. There has been conjecture that this might become a matter of great importance because small temperature increase could cause a partial melting of the ice caps of the earth causing continental flooding and devastating effects on man.

Air pollution can cause death, impair health, reduce visibility, bring about vast economic losses and contribute to the general deterioration of both our cities and country-side. It can also cause intangible losses to historical monuments such as the Taj Mahal which is believed to be badly affected by air pollution.

On account of large scale industrial activities in advanced countries

notably the USA, UK, and other European countries, fall of acid rain has been reported in Scandinavia. This has reduced forest growth in Scandinavia. In Canada, thousands of lakes have been destroyed due to acid rain. Apart from the international issues involved, the basic ecology is affected. Large scale deforestation apart from creating an imbalance in the oxygen proportion of the atmosphere, affects weather and rain patterns as well. Industrial activity, particularly in thermal power stations, cement plants, oil refineries, chemical complexes, metallurgical industries, steel plants and fertiliser complexes, causes major problems of air pollution. The effects of air pollution are felt more by the elderly and chest and respiratory complaints are very common among them. Tragic instances of death have also been reported in air pollution episodes such as the London smog of 1952, and the Bhopal gas tragedy of 1984.

It is, therefore, a matter of great importance that engineers of all disciplines consciously incorporate in their designs sufficient constraints and safeguards to ensure that they do not contribute to atmospheric pollution. In addition, they must apply their ingenuity and problem-solving abilities to eliminate air pollution where it exists and restoring the natural environment.

There are three methods of identifying air pollution:

1. Sensory recognition
2. Physical measurement of pollution
3. Effects on plants, animals, and buildings.

These methods are widely used and they have their merits and demerits.

1. Sensory recognition—Usually the first awareness of an air pollution problem is through some effects on the individual. These are:

- (a) Strong or unusual odours
- (b) Reduction in visibility
- (c) Eye irritation
- (d) Acid taste in the mouth
- (e) Feel of grit under foot

These are highly subjective phenomena and vary from individual to individual.

2. Physical measurement—While sensory perception may provide the first indication of the presence of most of the contaminants in the air, it is often not possible to detect trace quantities of many air-borne toxic substances or the presence of radioactive matter through the senses. Their identification requires physical measurement by standard methods of sampling and analysis.

3. Effects on plants, animals and buildings—Effects of air pollution can be observed on the growth of plants and health of animals. Similarly, its deleterious effect on buildings can also be observed. Thus plants, animals, and buildings act to some extent as indicators of certain atmospheric impurities.

These and other aspects of air pollution are dealt with in detail in the subsequent chapters.

2

Sources and Classification of Air Pollutants

2.1 Introduction

An inventory of air contaminants is a necessary first step towards control of air pollution. Air pollutants can be either natural or may be the result of various activities of man like industrial operations. The industrial contaminants can be either by-products of external combustion like smoke, dust, and sulphur oxides or by-products of internal combustion like the reactions in petrol and diesel engines. Further, the emissions can be either primary pollutants or secondary pollutants. The various sources of pollutants can also be broadly grouped under either stationary sources or mobile sources. All these are explained in detail in the following pages.

2.2 Classification of Pollutants

Air pollutants can be classified as follows:

1. Natural contaminants
e.g., natural fog, pollen grains, bacteria, and products of volcanic eruption.
2. Aerosols (particulates)
e.g., dust, smoke, mists, fog and fumes.
3. Gases and vapours

The various gases and vapours, which are important air contaminants are given in Table 2.1.

Table 2.1 *Air Contaminants*

No.	Group	Examples
1.	Sulphur compounds	SO ₂ , SO ₃ , H ₂ S, mercaptans
2.	Nitrogen compounds	NO, NO ₂ , NH ₃
3.	Oxygen compounds	O ₃ , CO, CO ₂
4.	Halogen compounds	HF, HCl
5.	Organic compounds	Aldehydes, hydrocarbons
6.	Radioactive compounds	Radioactive gases

In addition to the above, studies by various investigators have indicated, that some of these contaminants undergo chemical reactions when they enter the atmosphere. As a result, the end products formed are more harmful than the original contaminants. For example, it is reported that unsaturated hydrocarbons react with nitrogen dioxide in sunlight to form smog.

2.2.1 Natural Contaminants

Among natural contaminants pollen is important because of its peculiar properties irritating to some individuals. Pollen grains are the male gametophytes of gymnosperms and angiosperms and they are discharged into the atmosphere from weeds, grasses and trees. Because of wind pollination, thousands of pollen grains are liberated. While air transported pollen grains range chiefly between 10 and 50 μ (micron) in size, some have been found to be as small as 5 μ and as large as 100 μ in diameter.

From the point of view of pollution, air-borne pollutants are significant because of the allergic responses produced in sensitive individuals. Many people suffer from asthma or hay fever. While most victims have an uncomplicated type of hay fever in which the symptoms disappear at the end of the pollen season, some develop bronchitis, bronchial asthma, and dermatitis. (See Allergic Agents, Sec. 5.5.12.)

2.2.2 Aerosols

Aerosols refer to the dispersion of solid or liquid particles of microscopic size in gaseous media, such as dust, smoke, or mist.

An aerosol can also be defined as a colloidal system in which the dispersion medium is a gas and the dispersed phase is solid or liquid.

The term 'aerosol' is used during the time it is suspended in the air. After it has settled either by virtue of its weight, by agglomeration, or by impact on a solid or liquid surface, the term no longer applies. Thus, particulate matter is an air pollutant only when it is an aerosol. However, it is a nuisance both as an aerosol (visibility reduction) and as settled or deposited matter (soiling of surfaces, corrosions).

Aerosols differ widely in terms of particle size, particle density and their importance as pollutants. Their diameters generally range from 0.01 μ or less, up to about 100 μ . The following are the various aerosols.

Dust

Dust is made up of solid particles predominantly larger than those found in colloids and capable of temporary suspension in air or other gases. They do not tend to flocculate except under electrostatic forces; they also do not diffuse but settle under the influence of gravity.

Dust is produced by the crushing, grinding, etc., of organic and inorganic materials. Generally they are over 20 μ in diameter, although some are smaller. Fly ash from chimneys varies from 80–3 μ ; cement, from 150–10 μ ; foundry dust, from 200–1 μ . Most of the dust particles settle to the ground as dust fall, but particles 5 μ or smaller tend to form stable suspensions.

6 Air Pollution

Smoke

Smoke consists of finely divided particles produced by incomplete combustion. It consists predominantly of carbon particles and other combustible materials. Generally the size of the particles is less than $1\ \mu$. The size of coal smoke particles range from $0.2\text{--}0.01\ \mu$ and oil smoke particles from $1.0\text{--}0.03\ \mu$.

Mists

This term refers to a low concentration dispersion of liquid particles of large size. In meteorology, it means a light dispersion of minute water droplets suspended in the atmosphere. Natural mist particles formed from water vapour in the atmosphere are rather large, ranging from $500\text{--}40\ \mu$ in size. The particles may coalesce.

Fog

Fog refers to visible aerosols in which the dispersed phase is liquid. Formation by condensation is usually implied. In meteorology, it refers to dispersion of water or ice in the atmosphere near the earth's surface reducing visibility to less than $\frac{1}{2}$ km. In natural fog the size of the particles ranges from $40\text{--}1.0\ \mu$.

Fumes

These are solid particles generated by condensation from the gaseous state, generally after volatilisation from melted substances, and often accompanied by a chemical reaction such as oxidation. Fumes flocculate and sometimes coalesce.

Table 2.2 indicates the major sources of atmospheric dust.

2.2.3 Gases

Following are the gases in air pollutants:

Sulphur Dioxide

This is one of the principal constituents of air pollutants. The main source of sulphur dioxide is the combustion of fuels, especially coal. Therefore, its concentration in the atmosphere depends upon the sulphur content of the fuel used for heating and power generation. The sulphur content of fuels varies from less than 1% for good quality anthracite to over 4% for bituminous coal. In the USA in recent years, there has been a progressive decrease in the average atmospheric concentrations of sulphur dioxide, of several cities, owing to the increased use of coal with a low sulphur content. Air pollution control measures in St. Louis prohibit the use of high-sulphur coal.

Most crude petroleum products contain less than 1% sulphur; a few

Table 2.2 *Sources of Atmospheric Dust*

Sources	Examples
1. Combustion	Fuel burning (coal, wood, fuel oil) Incineration (house and municipal garbage) Others (open fires, forest fires, tobacco smoking)
2. Materials handling and processing	Loading and unloading (sand, gravel, coal, ores, lime, cement) Crushing and grinding (ores, stone, cement, rocks, chemicals) Mixing and packaging (chemicals, fertilisers) Food processing (flour, corn starch, grains) Cutting and forming (saw mills, wall board, plastics) Metallurgical (foundries, smelters) Industrial (paper, textiles manufacture)
3. Earth-moving operations	Construction (road, buildings, dams, site clearance) Mining (blasting) Agriculture (soil filling, land preparation) Winds
4. Miscellaneous	House cleaning Mud road cleaning Crop spraying Poultry feeding Engine exhaust

contain up to 5%. Refining processes tend to concentrate sulphur compounds in the heavier fractions. Fuel gases also contain sulphur, but, in small quantities.

About 80% of the sulphur in coal and nearly all that in liquid and gaseous fuels is found in flue gases in the form of sulphur dioxide. The remaining sulphur in coal is present as inorganic sulphur and thus remains in the ash. Generally, the concentration of sulphur dioxide in flue gases ranges from 0.05–0.25%, and occasionally is as high as 0.4%.

Another common source of sulphur dioxide in the atmosphere, is metallurgical operations. Many ores, like zinc, copper and lead, are primarily sulphides. During the smelting of these ores, sulphur dioxide is evolved in stack concentrations of 5–10% (SO₂). But, this can be recovered in the form of sulphuric acid.

Among the miscellaneous operations releasing sulphur dioxide into the atmosphere are sulphuric acid plants and paper manufacturing plants. The quantities are usually low and therefore easily amenable to control measures.

The open burning of refuse and municipal incinerators also contribute some amount of sulphur dioxide to the atmosphere.

Hydrogen Sulphide

Hydrogen sulphide is a foul smelling gas. The sources of its natural emission include anaerobic biological decay processes on land, in marshes

8 Air Pollution

and in the oceans. Volcanoes and natural water springs emit hydrogen sulphide to some extent.

One of the major sources of hydrogen sulphide is the Kraft pulp industry, which uses a sulphide process for manufacturing paper. The other industrial sources of hydrogen sulphide are petroleum refineries, coke-oven plants, viscose rayon plants, and some chemical operations.

Other sulphur compounds that are of interest in air pollution, principally because of their strong odours, are methyl mercaptan ($\text{CH}_3 \text{SH}$), dimethyl sulphide ($\text{CH}_3 \text{S CH}_3$), dimethyl disulphide ($\text{CH}_3 \text{SS CH}_3$) and their higher molecular homologs. The mercaptans are emitted in mixtures of pollutants from some pulp mills, petroleum refineries, and chemical manufacturing plants.

Hydrogen Fluoride

The major sources of fluorides are the manufacture of phosphate fertilisers, the aluminium industry, brick plants, pottery, and ferro-enamel works. Small amounts are also emitted from other metallurgical operations, such as zinc foundries and open-hearth steel furnaces. Small amounts are also liberated in the burning of coal, which normally contains about 0.01% fluorine.

Hydrogen fluoride is an important air contaminant even in extremely low concentrations of 0.001–0.10 ppm by volume. In these concentration levels, hydrogen fluoride is more important in terms of injury to vegetation and animals than in terms of injury to humans (see Sec. 7.5.2 and 6.2.1). The high degree of toxicity of fluorine compounds renders the control of such emissions imperative for industries manufacturing aluminium and phosphate fertilisers.

Chlorine and Hydrogen Chloride

Chlorine is found in polluted atmospheres as the element itself (chlorine), as hydrogen chloride, as chlorine-containing organic compounds such as perchloroethylene and as inorganic chlorides. The last mentioned compounds are solids and hence found in particulate form; the other materials mentioned are present as gases.

The most common sources of chlorine in the atmosphere are from operations in which it is manufactured or used to produce other chemicals. Also as chlorine is used in water purification plants, in sewage plants and in swimming pools, equipment failure sometimes leads to leakage of chlorine into the atmosphere.

Hydrogen chloride is evolved in numerous industrial chemical processes, but it is so easy to recover, that little reaches the atmosphere.

The main effects of chlorine and its compounds are respiratory irritation from chlorine, corrosion by hydrogen chloride, and damage to vegetation from chlorine and hydrogen chloride.

Oxides of Nitrogen

It is probable that oxides of nitrogen are the second most abundant atmospheric contaminants in many cities, ranking next to sulphur dioxide. Generally, the highest concentration of nitrogen oxides in gaseous emissions occurs in effluents from industries where nitric acid is produced or used in chemical reactions. The next highest concentration is in automobile exhausts. Then come effluents from large power plants, and then to a small extent those from low heat burners and furnaces.

Out of seven oxides of nitrogen (N_2O , NO , NO_2 , NO_3 , N_2O_3 , N_2O_4 , N_2O_5), only nitric oxide and nitrogen dioxide arise from many human activities and are classified as pollutants. In atmospheric analyses they are usually reported as 'total oxides of nitrogen' or " NO_x ". It is a standard practice in the chemical industry to absorb and recover significant quantities of oxides of nitrogen.

Ammonia and ammonium salts are not important air contaminants. Ammonia is an important raw material in fertiliser and organic chemical industries and in the manufacture of nitric acid by the oxidation process. Its recovery is a matter of fundamental importance in the economical operation of such processes.

Carbon Monoxide

Carbon monoxide, an odourless and colourless gas has its major origin in the incomplete combustion of carbonaceous materials. It is a highly poisonous gas and is generally classified as an asphyxiant.

The chief source of carbon monoxide in the atmosphere is combustion, especially due to automobile exhausts. However, except for motor vehicles and other internal combustion engines, very little carbon monoxide is found in the gaseous emissions from properly adjusted, properly operated installations. Although certain industrial operations, such as electric and blast furnaces, some petroleum refining operations, gas manufacturing plants, and coal mines, are potential contributors of carbon monoxide to the atmosphere, automobile exhausts are by far the most important source.

Ozone

The origin of ozone that is found in the air has not been clarified, but it is likely that combustion and sunlight are involved in its production. (See Chapter 12—Photochemical air pollution). Ozone is poisonous and smelly. It exists in great abundance under natural conditions in the upper atmosphere.

Aldehydes

These are produced by the combustion of gasoline, diesel oil, fuel oil, and natural gas. Incomplete oxidation of motor fuel and lubricating oils leads

10 Air Pollution

to the formation of aldehydes. Lower aldehydes may be present in the atmosphere in concentrations about as high as sulphur dioxide. They may also be formed in the air because of photochemical reactions. Formaldehyde is irritating to the eyes.

Organic Vapours

These contaminants include a large number of chemical compounds, including paraffins, olefins, acetylenes, aromatic hydrocarbons, chlorinated hydrocarbons, etc. They are produced by combustion processes (particularly in automobiles), household incinerators, and petroleum processes. It is also probable that they undergo changes in the atmosphere which contribute to the formation of smog.

Radioactive Gases

A major source of radioactive gases and particulate is the nuclear power reactor and related fuel handling facilities. The other sources are experimental accelerators, testing of nuclear bombs in the atmosphere, agricultural, industrial and medical use of radioactive isotopes. Another source of radioactive particulates and gases that is increasing in importance, is the nuclear fuel reprocessing plant.

Table 2.3 indicates the various sources of air pollution

Table 2.3 Sources of Air Pollution

No.	Class	Aerosols	Gases and vapours
1.	Combustion processes (domestic burning, thermal power plants, cars, trucks, aeroplanes, and railways. Also refuse burning)	Dust, fume, smoke	SO ₂ , NO ₂ , CO, organic vapours, odours
2.	Chemical processes (paper mills, cement, fertilisers, etc.)	Dust, fume, mist	Process-dependent (SO ₂ , CO, NH ₃ , NO ₂ , organic vapours, odours)
3.	Petroleum operations	Dust, mist	SO ₂ , H ₂ S, NH ₃ , CO, hydro-carbons, mercaptans
4.	Metallurgical processes (aluminium refineries, steel plants)	Dust, fume	SO ₂ , CO, fluorides, organic vapours
5.	Mineral processing	Dust, fume	Process-dependent (SO ₂ , CO, fluorides, organic vapours)
6.	Food and feed operations	Dust, mist	Odourous materials
7.	Agricultural activities		Organic phosphates,
	(a) Crop spraying	Dust, mist	chlorinated hydro-carbons
	(b) Field burning	Smoke, fly ash	sulphur oxides, organic vapours
8.	Nuclear energy programmes		
	(a) Fuel fabrication		Fluorides
	(b) Ore preparation	Dust	Iodine-131 and Argon-41
	(c) Bomb explosion		Radioactive gases (Sr-90, Cs-137, C-14, etc.)

2.2.4 Primary and Secondary Air Pollutants

Air pollutants can also be broadly classified into two general groups—primary air pollutants and secondary air pollutants.

Primary air pollutants are those emitted directly from identifiable sources.

Examples of primary air pollutants:

1. Finer particles (less than $100\ \mu$ in diameter)
2. Coarse particles (greater than $100\ \mu$ in diameter)
3. Sulphur compounds
4. Oxides of nitrogen
5. Carbon monoxide
6. Halogen compounds
7. Organic compounds
8. Radioactive compounds

Finer aerosols include particles of metal, carbon, tar, resin, pollen, bacteria, etc.

Secondary air pollutants are those which are produced in the air by the interaction among two or more primary pollutants, or by reaction with normal atmospheric constituents, with or without photoactivation.

Examples of secondary air pollutants:

1. Ozone
2. Formaldehyde
3. PAN (peroxy acetyl nitrate)
4. Photochemical smog
5. Formation of acid mists (H_2SO_4) due to reaction of sulphur dioxide and dissolved oxygen, when water droplets are present in the atmosphere.

Smog

Smog is a synchronism of two words—smoke and fog. Smog can be of two types—photochemical or coal induced.

Photochemical smog is restricted to highly motorised areas in metropolitan cities, e.g., Los Angeles. It occurs under adverse meteorological conditions when the air movement is restricted. Smog is caused by the interaction of some hydrocarbons and oxidants under the influence of sunlight giving rise to dangerous peroxy acetyl nitrate (PAN). Its main constituents are nitrogen oxides, PAN, hydrocarbons, carbon monoxide and ozone. It reduces visibility, causes eye irritation, damage to vegetation and cracking of rubber.

The fog from burning coal covers urban areas at night or on cold days when the temperature is below 10°C and when calm meteorological conditions prevail, e.g., London (December 1952). This fog consists of smoke, sulphur compounds and fly ash. Prolonged exposure to smog may result in a high mortality rate especially among the elderly and those who have

12 Air Pollution

histories of chronic bronchitis, asthma, broncho-pneumonia and other lung or heart diseases.

2.2.5 Stationary and Mobile Sources

Emissions (air pollutants) may be classified by source, as stationary or mobile. Another method of classifying emission sources is by:

1. Point sources (large stationary sources)
2. Area sources (small stationary sources and mobile sources with indefinite routes)
3. Line sources (mobile sources with definite routes)

Table 2.4 gives a picture of emission inventory source classification.

Table 2.4 *Emission Inventory Source Classification*

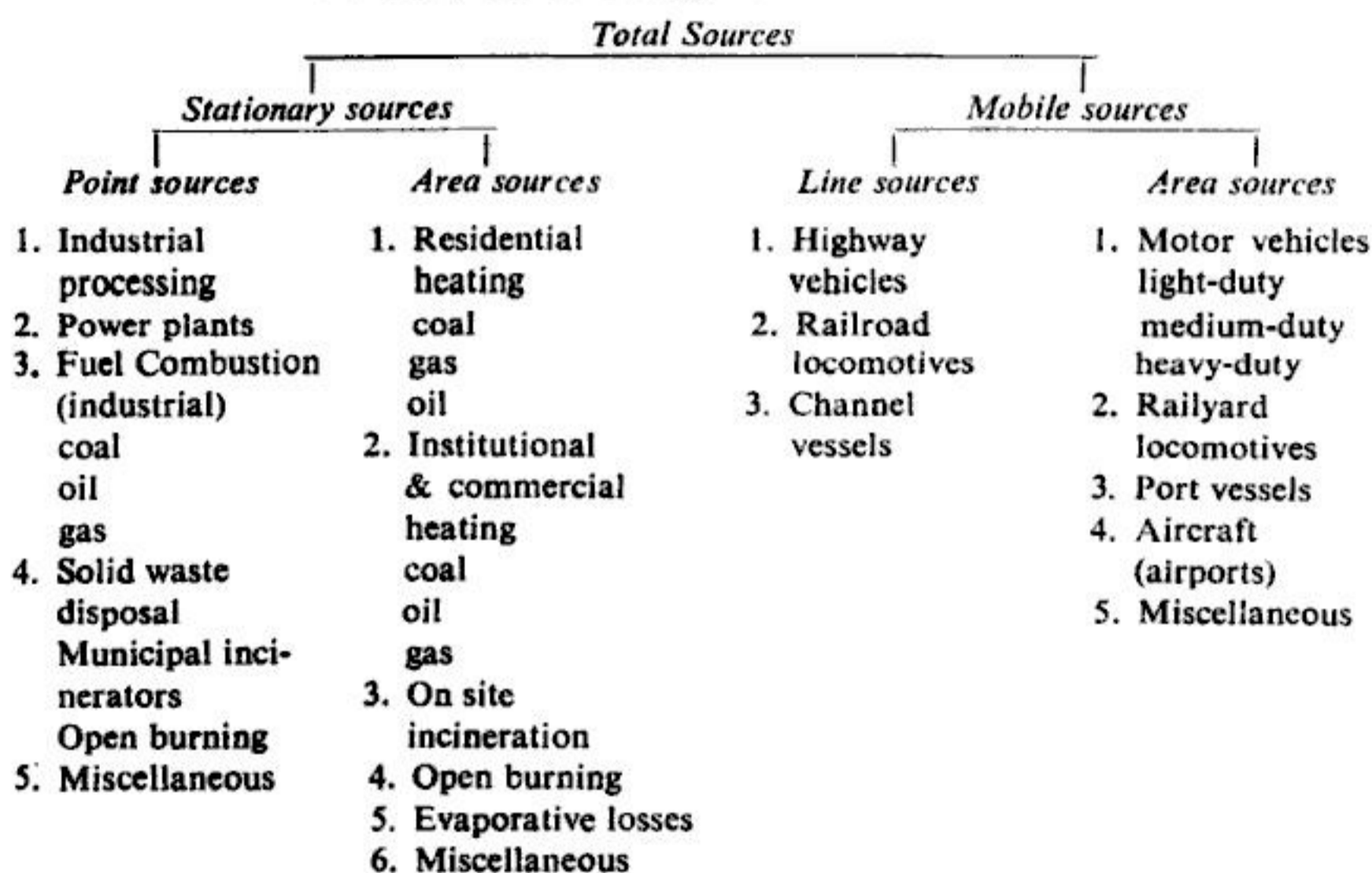

QUESTIONS

1. Classify air pollutants into different categories, indicating their sources.
2. What are the types and sources of particulate matter causing air pollution? Briefly explain them.
3. Identify the various pollution sources of the following air contaminants
 - (a) Sulphur dioxide
 - (b) Hydrogen sulphide
 - (c) Hydrogen fluoride
 - (d) Carbon monoxide
 - (e) Oxides of nitrogen
 - (f) Hydrocarbons
4. What is meant by 'Smog'? Discuss its cause and effects.

5. List the sources of atmospheric dust.
6. List out the industries that cause major air pollution problems.
7. Distinguish between
 - (a) Primary and secondary air pollutants
 - (b) Stationary and mobile sources of air pollutants
8. Explain the following terms with respect to air pollutants
 - (a) Point sources
 - (b) Area sources
 - (c) Line sources
9. Write short notes on:
 - (a) Aerosols
 - (b) Smog
10. Describe the various air pollution sources in an industrialised city like Bombay.

3

Meteorology and Air Pollution

3.1 Meteorological Factors Influencing Air Pollution

The degree to which air pollutants discharged from various sources concentrate in a particular area depends largely on meteorological conditions. The application of dispersion theory and a knowledge of local weather conditions are necessary to determine the required stack height for an emission, and to evaluate the intensity of air pollution. Even though the total discharge of contaminants into the atmosphere in a given area remains constant from day to day; the degree of air pollution may vary widely because of differences in meteorological conditions. In a specified place the emission of pollutants may be the same but it is the weather that can trigger an air pollution episode.

The important meteorological parameters that influence air pollution can be classified into primary parameters and secondary parameters.

Primary parameters are:

1. Wind direction and speed
2. Temperature
3. Atmospheric stability
4. Mixing height

Secondary parameters are:

1. Precipitation
2. Humidity
3. Solar radiation
4. Visibility

The parameters vary widely as a function of latitude, season and topography.

Just as weather affects the severity of air pollution, air pollution, may, in turn, affect weather conditions. Air pollution may influence the weather in several ways. Visibility may be reduced, fog frequency and duration may be increased and the incoming solar radiation may be decreased, particularly in the ultra-violet end of the spectrum.

3.1.1 Wind Direction and Speed

The direction and speed of surface winds govern the drift and diffusion of

air pollutants discharged near the ground level. The higher the wind speed at or near the point of discharge of pollution, the more rapidly are the pollutants carried away from the source. The pollutants so dispersed will not exist at the same concentration but will rapidly be diluted with greater and greater volumes of air. On the other hand, when wind speeds are low, pollutants tend to be concentrated near the area of discharge and the longer the periods of such light winds, the greater will be the concentration of pollutants. Further, gustiness, a very important characteristic of surface winds is directly proportional to its speed and determines the extent to which the pollutants are mixed and diluted with the surrounding air. Other things being equal, the concentration downwind from a source will be inversely proportional to wind speed. In rough terrain, it cannot be assumed that the wind direction and speed near the source govern the subsequent motion of the contaminants. Hills may deflect the air flow either horizontally, vertically, or both, the amount of deflection depending on the vertical stability of the atmosphere. In valleys, the winds carrying a pollutant tend to flow either up or down the valley, following its meanderings. The deeper the valley, the more pronounced is this channelling effect.

3.1.2 Atmospheric Stability and Temperature Inversions

In well mixed air which is dry, for every 1000 ft (300 m) increase in altitude, the temperature decreases by about 3.3°F (about 1.8°C). This vertical temperature gradient is known as the 'lapse rate' and the value given is the normal lapse rate. When the reverse or negative lapse rate occurs, a dense cold stratum of air at ground level gets covered by lighter warmer air at higher level. This phenomenon is known as 'inversion'. During inversion, vertical air movement is stopped and pollution will be concentrated beneath the inversion layer, i.e., in the denser air at ground level. As a result, during temperature inversion, the atmosphere is stable and very little turbulence or mixing takes place. Under such conditions, pollutants in the air do not disperse.

Inversion is a frequent occurrence in the autumn and winter months and the accumulation of smoke and other contaminants further aggravates pollution by preventing the sun's rays from warming the ground and the adjacent air. Fog is commonly associated with inversions, because the temperature of the air at ground level falls below the dew point of the water vapour in the air. Narrow valleys are favourable to inversions since horizontal air movement is restricted. At the time of inversions, visibility is greatly reduced and contaminants are at a maximum.

Types of Inversion

(a) Radiation inversion: It usually occurs at night, when the earth loses heat by radiation and cools the air in contact with it. If the air is moist and its temperature is below the dew point, fog will form. The cool air stratum is covered by warmer air, and the vertical movement is stopped until the

16 Air Pollution

sun warms the lower air, next morning. This type of inversion is more common in winter than in summer because of the longer nights. Valley areas, because of the restriction of horizontal air movement by surrounding high ground, may frequently have such inversions.

In India, because of intense solar heating of the ground, inversions are broken within a few hours after sunrise. However, simultaneous occurrence of fog or mist prolongs the duration of inversion by cutting out sunlight reaching the ground.

(b) Subsidence inversion: It occurs at modest altitudes and often remains for several days. It is caused by sinking or subsiding of air in anti-cyclones (high pressure areas surrounded by low pressure areas). The air circulating around the area descends slowly at the rate of about 1000 m per day. As the air sinks, it is compressed and gets heated to form a warm dense layer. This acts as a lid to prevent the upward movement of contaminants. The inversion height may vary from the ground surface to 1600 m. When it drops to less than 200 m, extreme pollution occurs.

Some times both radiation inversion and subsidence inversion may occur simultaneously. Such a phenomenon is known as 'double inversion'.

Adiabatic Lapse Rate

The change of air temperature with height has a profound influence on the upward lift of the air pollutants discharged into the atmosphere and hence on their ultimate dispersion and dilution. The lapse rate of a parcel of dry air as it moves upward in a hydrostatically stable environment and expands slowly to lower environmental pressure without exchange of heat, is known as the 'adiabatic lapse rate'. The dry adiabatic lapse rate is $0.98^{\circ}\text{C}/100\text{ m}$. Under conditions of adiabatic lapse rate, a smoke plume will rise directly into the atmosphere by virtue of low density because of higher temperature until it reaches air of similar density. In many situations, however, because of external heating or cooling effects, the lapse rate may be greater or less than the adiabatic rate. The two most important conditions from the point of air pollution are the super adiabatic lapse rate (rate more than adiabatic) and the negative lapse rate (inversion). On a clear summer day, rapid heating of the earth by the sun warms the air near the surface, to the point where the lapse rate is superadiabatic. Under this condition the atmosphere is said to be in unstable equilibrium, and marked vertical mixing of the air results. This is a condition when pollutants are dispersed rapidly.

3.1.3 Mixing Height

The fourth, primary meteorological parameter is the mixing height. It can be defined, as that height above the earth's surface to which related pollutants will extend, primarily through the action of atmospheric turbulence. It is usually related to one or more of the three factors: wind direction,

wind speed, and wind turbulence. Under certain circumstances, it may be related to all three.

3.1.4 Precipitation

Rainfall or precipitation exerts a two-fold cleansing action on the pollutants discharged into the atmosphere. It accelerates the deposition of particulate matter on the ground and hence its removal from the atmosphere. It also helps to remove the concentration of gaseous pollutants which are soluble in water. The washout by precipitation of air-borne radioactive wastes is a matter of particular concern. Precipitation can be determined by using various types of rain gauges.

3.1.5 Humidity

The moisture content of the atmosphere influences the corrosive action of the air pollutants and indicates the potentiality for fog formation in relation to the degree of air pollution. Of the various means by which humidity may be expressed, the relative humidity is most frequently used in air pollution studies.

3.1.6 Solar Radiation

Depending on the location, solar radiation can have a pronounced effect on the type and rate of chemical reactions in the atmosphere. The photochemical smog formation at Los Angeles is a typical example of the effect of solar radiation on air pollution.

The application of these meteorological factors may be considered in the control of pollution from an industrial plant, in the selection of its location, in the design of equipment and in its day-to-day operation. In addition, these factors are to be taken into account in laying out zones for industrial use, in identifying causal factors in existing pollution problems and in establishing air quality criteria. The influence of both regional and local weather should be considered.

3.2 Methods for Measurement of Meteorological Variables

A meteorological instrument must possess an acceptable degree of accuracy and sensitivity. Also, it should be simple and durable. In our country the National Environmental Engineering Research Institute (NEERI) has developed some devices for measuring the meteorological variables.

3.2.1 Wind Direction Recorder

The patented instrument of the NEERI for measuring wind direction is a simple one, which employs the conventional wind vane to sense the

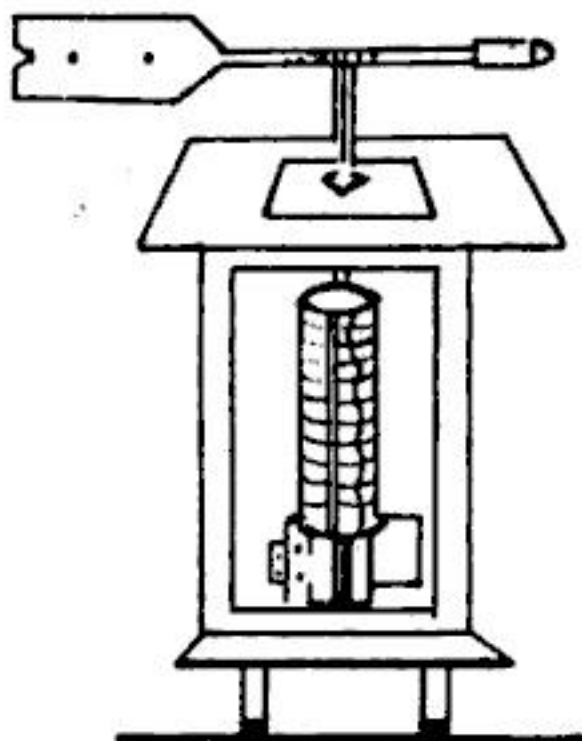

Fig. 3.1 *Wind direction recorder*

direction. It is automatic and operated mechanically without any power supply. The instrument continuously records on an attached chart the direction of the wind with time (Fig. 3.1).

Surface Wind Direction

There are four main types of wind vanes for measuring direction

1. Flat plate vane
2. Splayed vane
3. Aerofoil vane
4. Running average anemograph

Flat plate vane: In this type the sensing element which governs the azimuth angle of a vertical shaft specifying the wind direction, is a vertical plate which is mounted at one end of a horizontal rod. There is a counter weight at the other end of the horizontal rod. The rod is fastened to the vertical shaft. Wind pressure acting on the flat plate keeps the counter weight heading into the wind.

Splayed vane: In this instrument, two flat plates which are joined at a small angle at one end of a horizontal rod act as the wind direction sensor.

Aerofoil vane: In this instrument the vane has an aerofoil cross-section, with the span often being three or four times the chord.

Running average anemograph: It is often advantageous to be able to directly obtain a recording of the running average of the wind speed or direction or both. In averaging the wind direction, a difficulty arises from the discontinuity $360^{\circ}-0^{\circ}$ as the wind direction fluctuates around north. An anemograph which automatically produces the running averages of both wind speed and direction has been developed.

Wind Direction Aloft

The wind direction at the height of a plume from one or more stacks is important in some investigations. All the available following methods discussed involve considerable time and effort.

(a) **Pilot balloons (Pibals):** In this method a small balloon inflated with hydrogen or helium is left aloft and the direction of the wind aloft is determined by tracking the balloon by means of one or more theodolites on the ground. The average wind direction is obtained using triangulation techniques at successive height intervals. The pilot balloon technique of determining wind aloft is of limited value because the balloon may be lost with low cloud, fog or smoke.

(b) Tetroons: A tetroon is a constant volume Mylar balloon in the shape of a tetrahedron which is kept in a zero lift condition and carried by the wind in an almost horizontal direction. Zero lift balloons are produced by filling pilot balloons with a mixture of two gases, one more dense and the other less dense than air. As the mixture of gases leaks from the balloon, the loss of the heavier gas causes a decrease in its weight. Thus an approximate mixture of gases will keep the balloon in a zero lift or balanced condition for lengthy periods of time. Such a balloon, when accurately tracked, acts as a sensor for wind direction. The advantage of this type of balloon lies in the fact that it can indicate wind trajectories near cities, over shorelines and in valleys where complicated patterns of airflow are commonly observed. If substantial distances are to be tracked, a radar installation with a transponder suspended from the tetroon will be required which is an expensive method.

(c) Kite balloons: A kite balloon is an elongated captive balloon with fins at one end. It acts as an ordinary captive spherical balloon in light winds and as a kite in stronger winds, thus maintaining altitude under both conditions. The azimuth angle of the horizontal projection of the tethering cable is measured at the ground to determine the wind direction at the height of the balloon. The inflating gas lost by slow leakage is replaced by refilling it at intervals.

(d) Radio and radar: In the radio method, a small radio transmitter is carried aloft by a freely rising balloon and is tracked. With the radar system, pulses of electrical energy emitted by the radar are reflected back to it by a target carried by the free balloon. The distance to the target as well as azimuth and elevation angles are measured by the system. This gives more accurate results than the radio direction finder. However, operation and maintenance costs of radio and radar theodolites are prohibitively high.

(e) Smoke trails: Information on wind directions aloft may be obtained by finding at intervals the position in space of smoke trails released above the ground by a rising rocket or an aeroplane. However, observations in fog, smoke, or at night, are not possible. Also, this method requires more operating personnel than the pilot balloon method.

3.2.2 Wind Speed Recorder

Instruments for measuring wind speed are called anemometers. If they are recording instruments they are known as anemographs. The most common type is the cup anemometer. The rate of rotation of the shaft to which the cups are attached indicates the wind speed and this is transmitted to a recorder or an indicating panel by either mechanical, optical or electrical means.

The NEERI has developed and patented a wind speed recorder (Fig. 3.2). In the instrument a four cup rotor is employed to sense the wind. The motion of the cup is transferred after reducing its speed by a gear system,

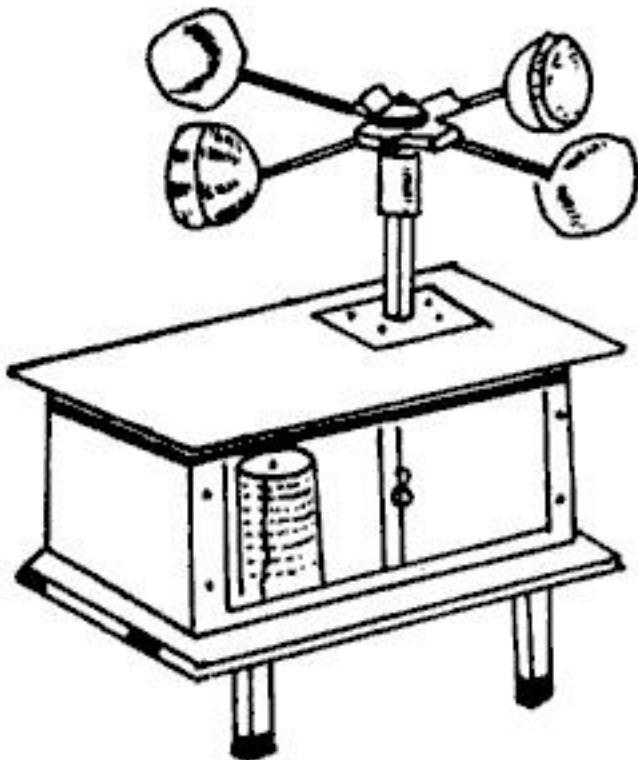

Fig. 3.2 *Wind speed recorder*

to the pen which makes a continuous rise and fall impression on chart paper. This rate of rise or fall is proportional to the wind speed.

The instrument gives a 24-hour record in one setting. Wind speed at a particular time and the average wind speed can be found out from this record.

3.2.3 Humidity Measurement (Whirling Psychrometer)

One of the simplest and most reliable instruments is the whirling psychrometer.

Two thermometers, one with a wet cloth surrounding the bulb, are whirled in the air. The temperatures of both dry bulb and wet bulb thermometers are noted. From the temperature difference between the dry bulb and wet bulb thermometers, the relative humidity of the air can be found by referring to psychrometric table.

Other instruments that can be used for measuring humidity are:

- (1) Hair hygrometer
- (2) Infra-red hygrometer.

3.2.4 Temperature Measurement

A common instrument for measurement of temperature is the thermometer. Mercury thermometers depend on thermal expansion while bimetallic thermometers are based on the differential expansion of two metals. The electrical resistance thermometer is based on the variation in electrical resistance of a metallic wire with change in temperature and a thermocouple is based on the electrical current which flows when two electrical conductors made of two different metals are joined together. All four types are used.

To obtain accurate readings, the thermometer must be shielded from radiant energy. Proper aspiration is also necessary to avoid the stagnation of the air inside the radiation shield. A motor aspirated radiation shielded temperature sensor for temperature inversion studies developed by NEERI is described.

In this temperature probe, a glass probe-bead type thermistor is used. The constructional details of the probe are shown in Fig. 3.3.

Two core shielded electrical contacts are taken from the thermistor leads. The thermistor is first wrapped in a shock absorbing material and is put into an exactly fitting stainless steel tube. A thin walled conical shaped metallic tip is fixed at one end of the stainless steel tube. The thermistor is pushed until its sensitive point makes a positive thermal contact with the

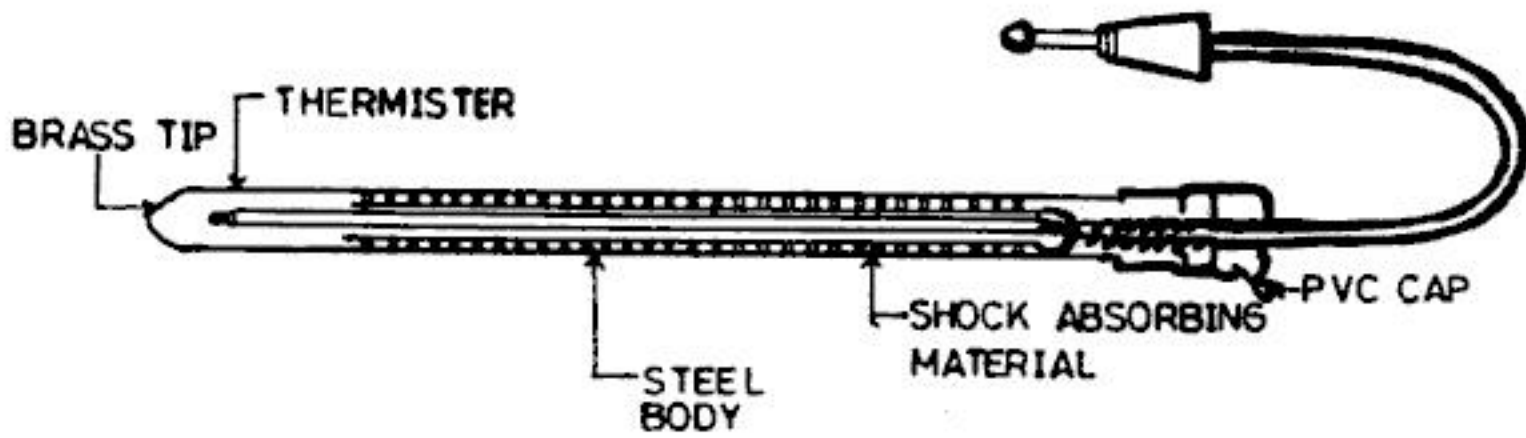

Fig. 3.3 Probe details

thin walled metallic tip. The open end of the stainless steel tube is closed with a PVC cap and the joint is made watertight with some adhesive.

Figure 3.4 gives the details of the radiation shield. It consists of two concentric PVC pipes *A* and *B* separated from each other by an air layer and supported at two positions by two polyvinyl chloride (PVC) rings R_1 and R_2 . PVC is preferred as it is a good heat insulator and at the same time is also a light material with sufficient strength. The temperature probe (TP) is positioned on the axis of the inner pipe with the help of a PVC sheet (*S*) and clamps C_1 and C_2 . The tip of the probe is kept 5–8 cm inside from the edges of the outer pipe and about 2.5 cm from the edges of the inner pipe. The outer surface of the outer pipe and the ends of the inner and outer surfaces of both the pipes are covered with aluminium foil having good emissivity.

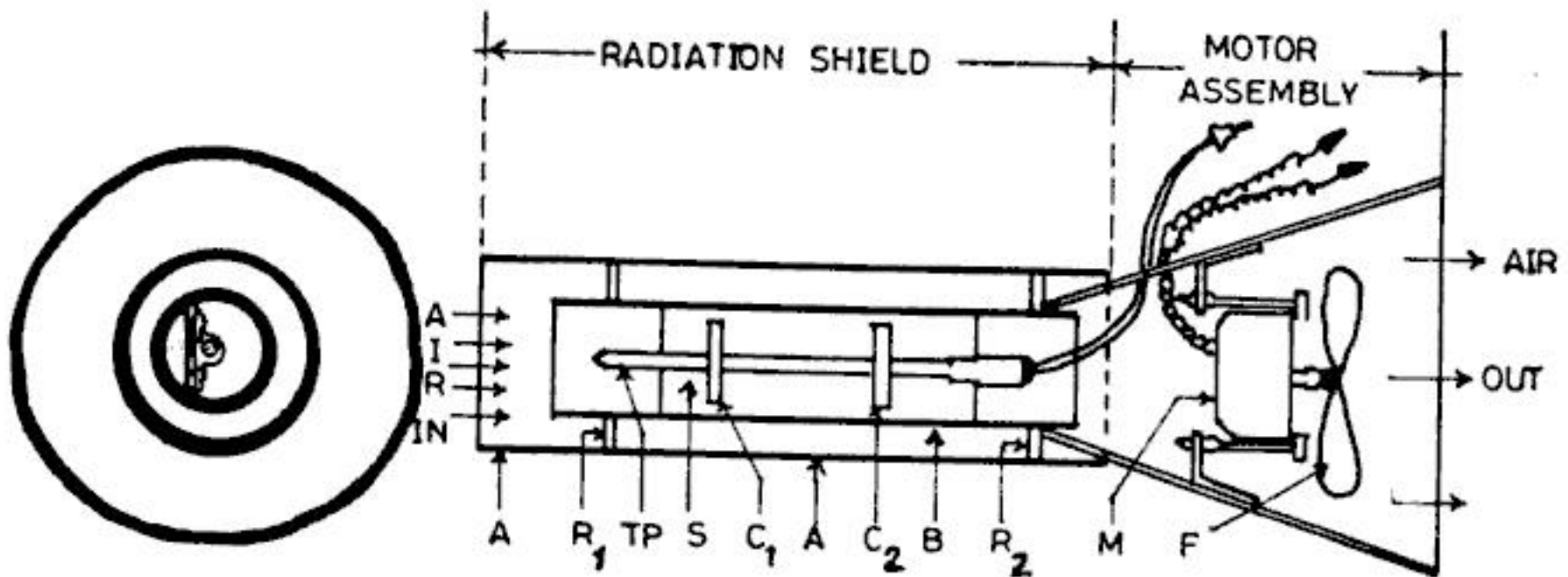

Fig. 3.4 Motor aspirated radiation shielded temperature sensor

A fan assembly is fixed at the other end of the pipes. A small fan (*F*) driven by a motor (*M*) working on 9–12 volts (dc) and mounted in a funnel shaped support, aspirates the air over the probe.

3.2.5 Solar Radiation Measurement

A knowledge of sunlight intensity is important specially in places where

photochemical smog formation takes place. Instruments used to measure the radiant energy from the sun are pyrheliometer, solarimeter and chemical actinometer.

3.3 Plume Behaviour

Plume refers to the path and extent in the atmosphere of the gaseous effluents released from a source, usually a stack.

The behaviour of a plume emitted from any stack depends on localized air stability. Typical situations as shown in the Fig. 3.5, are generally encountered in the lower atmosphere (less than 300 m above ground). Effluents from tall stacks, are often injected to an effective height of several hundred metres above ground because of the cumulative effects of buoyancy and velocity on plume rise. Other factors influencing plume behaviour

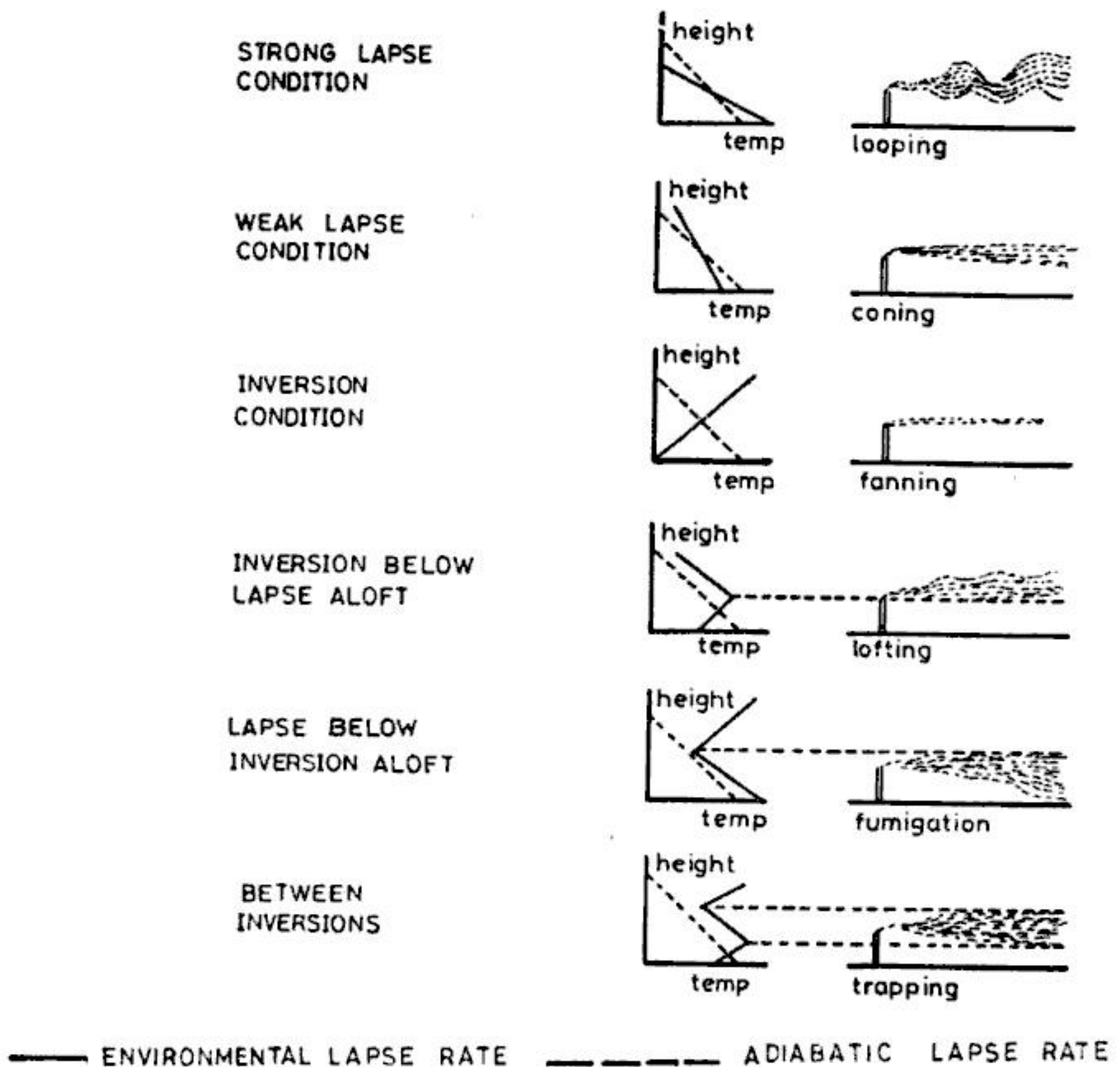

Fig. 3.5 Types of plume behaviour

are the diurnal variations in the atmospheric stability and the long term variations which occur with changing seasons.

Six types of plume behaviour are shown in Fig. 3.5. The spread of the plume is directly related to the vertical temperature gradient as shown on the left hand side of the figure.

1. **Looping:** It is a type of plume which has a wavy character. It occurs in a highly unstable atmosphere because of rapid mixing. The high degree of turbulence helps in dispersing the plume rapidly but high concentrations may occur close to the stack if the plume touches the ground.

2. **Coning:** It is a type of plume which is shaped like a cone. This takes place in a near neutral atmosphere (adiabatic condition) when the wind velocity is greater than 32 km/h. However, the plume reaches the ground at greater distances than with looping.

3. **Fanning:** It is a type of plume emitted under extreme inversion conditions. The plume, under these conditions will spread horizontally, but little, if at all vertically. Therefore, the prediction of ground level concentrations is difficult here.

4. **Lofting:** Lofting occurs when there is a strong lapse rate above a surface inversion. Under this condition, diffusion is rapid upward, but downward diffusion does not penetrate the inversion layer. Under these conditions, emissions will not reach the surface.

5. **Fumigation:** It is a phenomenon in which pollutants that are aloft in the air are brought rapidly to ground level when the air destabilizes.

6. **Trapping:** This refers to conditions where the plume is caught between inversions and can only diffuse within a limited vertical height.

The lofting plume is the most favourable with respect to minimising air pollution. The fumigating and trapping plumes are very critical from the point of ground level pollutant concentrations.

The observation of these visible smoke plumes is a useful practice to determine locations at which to take air samples. The knowledge of the characteristics of plumes is also helpful in dealing with invisible pollutants. However, in observing a plume, care should be taken to avoid optical illusions (for example, a plume may be visible for several kilometres yet not extend upward for a small fraction of a kilometre). For this, viewing simultaneously or successively from two points at right angles from the plume may be useful.

Various types of the plumes and their characteristics, occurrence and related weather conditions, etc., are shown in Table 3.1.

3.4 Single Stack and Multiple Source Pollution

Air pollution caused by effluents from a single or small group of stacks is a local problem. Effluent concentrations of concern generally occur at

Table 3.1 Various Types of Plumes and their Characteristics

Type of plume	Description of visible plume	Typical occurrence	Temperature profile and stability	Associated wind and turbulence	Dispersion and ground contact
Looping	Irregular loops dissipates in patches and relatively rapidly with distance.	During day time with clear or partly cloudy skies and intense solar heating.	Adiabatic or super adiabatic lapse rate. Unstable.	Light winds with intense thermal turbulence.	Disperses rapidly with distance, large probability of high concentrations sporadically at ground relatively close to the stack.
Coning	Cone shaped with horizontal axis, dissipates further downwind than looping plume.	During windy conditions, day or night. Layer type cloudiness favoured in day.	Lapse rate between dry adiabatic and isothermal. Neutral or stable.	Moderate to strong winds. Turbulence largely mechanical rather than thermal.	Disperses less rapidly with distance than looping plume, large probability of ground contact some distance downwind. Concentration less but persists longer than looping plumes.
Fanning	Narrow horizontal fan. No vertical spreading for kms downwind. If effluent is warm, plume rises slowly, then drifts horizontally.	At night and in early morning, any sea-son, usually favoured by light winds.	Inverted and isothermal lapse rate. Very stable.	Light winds. Very little turbulence.	Disperses slowly, concentration aloft high at relatively great distance downwind, small probability of ground contact, though increase in turbulence can result in ground contact.
Lofting	Loops or cone well defined bottom. Diffuses to top.	During change from lapse to inversion condition, usually near sunset on fair days.	Adiabatic lapse rate at stack top and above. Inverted below stack. Lower layer stable, upper layer neutral or unstable.	Moderate winds and considerable turbulence aloft, very light winds and little turbulence in layer below.	Probability of ground contact is small unless inversion layer is shallow, considered to be the best condition for dispersion since pollutants are dispersed in

upper air with small probability of ground contact.

Large probability of ground contact in relatively high concentration especially after plume has stagnated aloft.

Winds light to moderate aloft and light below. Thermal turbulence in lower layer, little turbulence in upper layer.

Adiabatic or superadiabatic lapse rate at stack top and below. Isothermal or inverted lapse rate above. Lower layer unstable or neutral upper layer stable.

During change from inversion to lapse condition, may occur with sea breeze in late morning or early afternoon.

Fan or cone with well defined cone and dragged or diffused bottom.

Fumigation

26 Air Pollution

distances ranging from the immediate vicinity of the stack to those of the order of several kilometres. At greater downwind distances, plumes formed by stack effluents become so diluted by diffusion in the ambient atmosphere, that concentrations may become negligibly small.

The combined effect of a large number of stack effluents spread over a large area (usually urban) produces a different type of air pollution problem which may have its principal area of concern at much greater distances. While the local pollution from any one stack may not be a problem, the combined effect of a large number of stacks produces serious urban pollution.

3.5 Wind Rose

A wind rose is defined as, "Any one of a class of diagrams designed to show the distribution of wind direction experienced at a given location, over a considerable period". In other words, the wind rose shows the prevailing direction of wind.

The most common form consists of a circle from which eight or sixteen lines emerge, one for each direction. The length of each line is proportional to the frequency of wind from that direction and the frequency of calm conditions is entered in the centre. There are many variations in the construction of wind roses. Some indicate the range of wind speeds from each direction, and some relate wind direction with other meteorological conditions.

Wind roses may be constructed from the data obtained over a given time period such as a particular month or season or a year. In constructing or interpreting wind roses, it is necessary to keep in mind the meteorological convention that wind direction refers to the direction from which the wind is blowing. A line or bar extending to the north on the wind rose indicates the frequency of winds blowing from the north.

The wind rose diagram is prepared using an appropriate scale to represent percentage frequencies of wind directions and appropriate index shades, lines etc., to represent various wind speeds. Observations corresponding to wind speed below 1 km/h are recorded as calm (Fig. 3.6).

Special wind roses are sometimes constructed like:

1. Precipitation wind rose
2. Smoke wind rose
3. Sulphur dioxide wind rose
4. Hydrocarbons wind rose

Instead of wind speed the parameters of precipitation, smoke, sulphur dioxide, hydro carbons etc. are attached to the wind direction. These are known as 'Pollution Roses'.

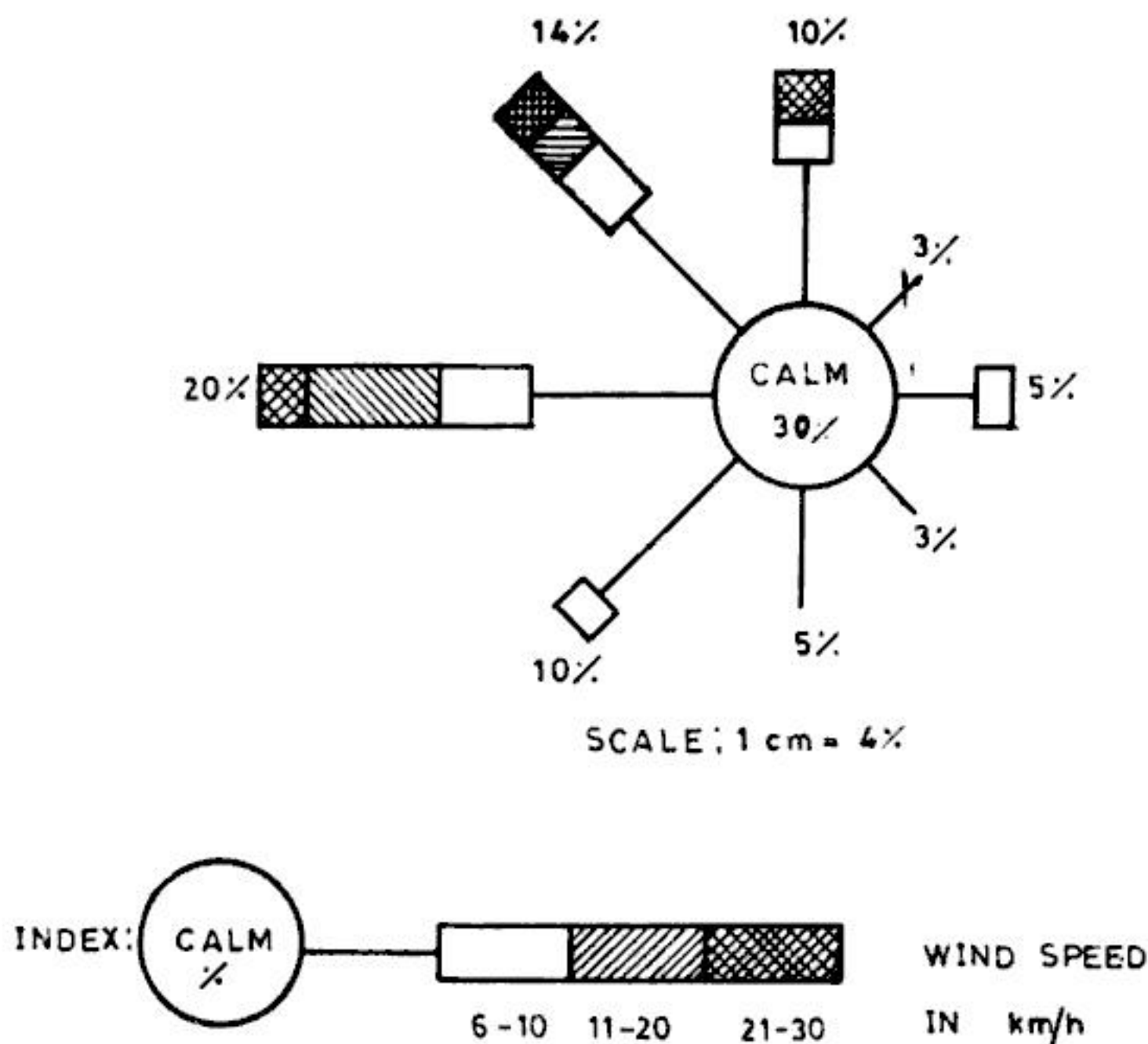

Fig. 3.6 Wind rose construction

3.6 Stack Effluent Dispersion Theories

The dilution of atmospheric wastes from elevated stacks is considered to occur in two stages, namely, plume rise and dispersion. In the first stage, the hot plume from the stacks goes up to a certain distance (defined as 'plume rise') into the atmosphere, due to buoyancy and momentum. Subsequently in the second stage, the plume spreads both vertically and horizontally by the dispersion process. The latter phase, i.e., the phase of pollutant dispersion can be described by the mathematics of diffusion, and has been the subject of considerable theoretical and experimental work by many workers in this field. On the other hand, all the plume rise equations are mostly empirical in nature, and none is uniformly accepted. However, the available theoretical and empirical equations can be effectively utilized to estimate the concentration of pollutants downwind from an emission source. These theories and equations, involving plume temperature, rate of emission, stack parameters such as height and diameter, meteorological factors like wind speed and direction, and the atmospheric stability, as well as the parameters representing, the topography of the region, have been employed successfully in many stack design and pollution control problems.

Another method of estimation of the effectiveness of the diffusion of the atmospheric waste, is the Wind Tunnel technique. In this method, a model of the stack and the adjoining area of interest is constructed in a wind tunnel, and the diffusion experiment conducted on the stack jets in that tunnel, satisfying the usual geometric and dynamic scaling parameters.

3.6.1 Effect of Dilution

Before going into the detailed description of plume rise and dispersion equations, it is worthwhile considering the process of dilution of the atmospheric wastes from the high level stack effluents, and also the principal meteorological factors influencing potential air pollution.

We have earlier seen, that the temperature of the atmosphere decreases with increase in height. The temperature gradient is closely interlinked with the stability for air masses and in the study of pollution in atmosphere, the temperature gradient (lapse rate) is of special significance. The temperature lapse rate γ is defined by

$$\gamma = \frac{-dT}{dZ} \quad (3.1)$$

where, T is the temperature and Z denotes vertical distance. (The negative sign indicates drop in temperature and often this sign is neglected.) The atmosphere may be considered to be adiabatic, except near the surface where air exchanges heat. For the adiabatic arrangement, the lapse rate $\gamma_d = 1^\circ\text{C}$ per 100 metres.

These conditions correspond to the neutral equilibrium in which a quantity of air can be displaced without showing any tendency to return to its original height or to move further away from it. The value of $0 < \gamma < \gamma_d$ refers to a stable condition. By a stable arrangement we mean the condition in which a quantity of air when displaced from one height to another is forced back to its original position. When the displaced air tends to move farther away from its original position, the condition is known as unstable, i.e., $\gamma > \gamma_d$. The lapse rate can be negative so that temperature increases with height and this condition is exceedingly stable and the meteorologists call such a distribution an inversion, i.e. $\gamma_d < 0$. Humidity has an influence on the distribution of temperature in the atmospheric air which is in general mixed with water vapour. If the water is in a gaseous state in air, its presence in small quantities makes little difference in the behaviour of the air mass as regards its stability. If, on the other hand, water vapour condenses, it affects the behaviour of the air since there is a great amount of heat release due to condensation.

The lapse rate, which may vary widely even in normal day conditions, plays an important role in the case of dilution of stack effluents in the atmosphere. The negative lapse rate or temperature inversion (the inversion layer may begin at ground level and extend up to a few hundred metres) may occur on clear nights with light winds when the air next to the surface is cooled by the cold ground surface. A low-level inversion always acts as a

barrier to vertical dilution of the pollutants even in an unstable surface layer and thus leads to an increase in the intensity of air pollution near the ground.

Gustiness of wind plays an important role in the dilution of atmospheric wastes. Gusts are a manifestation of atmospheric turbulence and a quantitative measure of gustiness gives the magnitude of turbulence. In other words, gustiness, g' , is the measure of the fluctuation of the mean velocity of a turbulent wind in a particular direction. If \bar{u} is the mean wind velocity in the x -direction, and v' is the component fluctuation of the mean wind in y -direction, then, the gustiness in the y -direction, g'_y is given by

$$g'_y = \frac{1}{\bar{u}} \sqrt{\overline{v'^2}} \quad (3.2)$$

Another important factor, wind-speed profile in the vertical plane, is a good measure of the degree of turbulence and atmospheric stability. In an unstable atmosphere, the variation in wind-speed profile with height is much less than under stable condition. If \bar{u}_1 is the mean wind at a particular elevation z_1 , and \bar{u} be the mean wind at any elevation z , \bar{u} can be expressed as follows as given by Sutton:

$$\bar{u} = \bar{u}_1 \left(\frac{z}{z_1} \right)^{n/(2-n)} \quad (3.3)$$

in which n is the turbulence parameter, $0 < n < 1$. The approximate value of n for a large lapse rate is 0.20 and for marked inversion is 0.50. Other meteorological factors which affect the turbulence or mixing of pollutants are humidity, vertical gradient in humidity, etc.

It is apparent that the form of stack emissions depend on the wind profile, turbulence of the wind, temperature distribution, etc.

3.6.2 Estimation of Plume Rise

The height of the stack is an important factor in determining the level of pollution at a given location. The 'effective height' of a stack is the sum total of height of stack and the rise of the plume beyond the stack exit. The plume rise depends on many factors like exit velocity, wind speed, diameter of the stack, temperature of the plume, lapse rate, etc. Several formulas are available to predict plume rise (Δh) from stacks. Most of the available plume rise formulas are empirical in nature, as the theory has not been developed adequately, and can be given by

$$\Delta h = K \frac{Q^\alpha}{\bar{u}^\beta} \quad (3.4)$$

in which α , β and K (dimensional) are constants, Q is the heat emission rate from stack. In the CCRL (Canadian Combustion Research Laboratory) equation, the values of $\alpha = 1/4$, $\beta = 1$, $K = 66.4$ where Q is expressed in kcal/s and \bar{u} in m/s. An extensive series of observations at the Tilbury Power Station show $\alpha = 1/4$, $\beta = 1$, $K = 450-500$ and Q and \bar{u} are expressed in MW and m/s respectively. It is also observed that K is a function of height of the source of emission.

30 Air Pollution

Alternatively, the plume rise may be considered due to buoyancy and momentum. For instance,

$$\Delta h = \Delta h \text{ buoyancy} + \Delta h \text{ momentum} \quad (3.5)$$

Following is the empirical formula of Moses and Carson.

$$\Delta h = C_1 \frac{V_s d}{\bar{u}} + C_2 \frac{Q_h^{1/2}}{\bar{u}} \quad (3.6)$$

where

Δh = Plume rise (m)

V_s = Stack exit velocity (m/s)

\bar{u} = Wind speed (m/s)

d = Stack diameter (m)

Q_h = Heat emission rate (kcal/s)

C_1, C_2 = Plume rise regression coefficients, which depends on atmospheric stability.

It is seen from the formula, that the first term evaluates the vertical momentum of the gases leaving the stack, and the second term evaluates the buoyancy force of the plume which is a function of heat content of the plume. Therefore, the magnitude of the plume rise is inversely proportional to wind speed, directly proportional to the sum of mass ejection rate, and the square root of heat content of the gases.

The Bureau of Indian Standards has suggested that the following Brigg's formula be used to compute plume rise for practical use (IS: 8829).

(a) For hot effluents with heat release of the order of 10^6 cal/s or more

$$\Delta h = 0.84 (12.4 + 0.09h) \frac{Q_H^{1/4}}{\bar{u}} \quad (3.7)$$

where

Q_H = heat release in calories per second,

h = height of the stack in metres,

\bar{u} = wind speed in m/s

(b) For not very hot releases and which can be counted as momentum sources above.

$$\Delta h = \frac{3W_0 D}{\bar{u}} \quad (3.8)$$

where W_0 is the efflux velocity of the same units as \bar{u} and D is the stack exit diameter.

It may be noted that although the available plume rise formulae predict well in a particular place for some particular conditions, none can be universally accepted due to empirical character. The lack of a complete theory concerning the rise of plumes in the atmosphere is probably a handicap to environmental engineers in the prediction of downwind pollution levels.

3.6.3 Dispersion Equations

The dispersion of pollutants is due to the turbulent flow of wind, and is

dependent on the atmospheric stability, gustiness, etc. The turbulent diffusion models for atmospheric pollutants are based on Fick's law of molecular diffusion. Assuming a continuity in the atmosphere and incorporating the mass balance equation in the diffusion equation we get,

$$\begin{aligned} \frac{\partial c}{\partial t} + u \frac{\partial c}{\partial x} + v \frac{\partial c}{\partial y} + w \frac{\partial c}{\partial z} \\ = \frac{\partial}{\partial x} \left(K_x \frac{\partial c}{\partial x} \right) + \frac{\partial}{\partial y} \left(K_y \frac{\partial c}{\partial y} \right) + \frac{\partial}{\partial z} \left(K_z \frac{\partial c}{\partial z} \right) \end{aligned} \quad (3.9)$$

in which K_x , K_y and K_z are diffusion coefficients in the x , y and z directions respectively, c is the concentration of the pollutants, u , v , and w denote the component velocities of wind in x , y , and z directions respectively and t refers to time.

For simultaneous deposition of particulate matters from a plume, the above equation is modified slightly by the addition of the vertical advective term $\bar{w} \partial c / \partial z$, on the right hand where \bar{w} is the velocity of the falling particles.

For a functional form for the distribution of pollutants, in addition to Fick's law, the knowledge of the shape of the distribution of concentration is required.

For continuous source the following type of Gaussian Distribution is assumed normally.

$$C(x, y, z) = \frac{Q}{\pi \sigma_y \sigma_z \bar{u}} \exp - \left\{ (x^2 / 2\sigma_x^2) + (y^2 / 2\sigma_y^2) \right\} \quad (3.10)$$

Where

- C = Concentration (g/m^3)
- Q = Pollutant release rate (g/s)
- σ_y, σ_z = Crosswind and vertical plume standard deviations (m)
- \bar{u} = Mean wind speed (m/s) at h_s , the height of the stack
- h = Effective stack height (m)
- x, y = Downwind and crosswind distances.

From the above equation it is seen that C , the ground level ($Z = 0$) concentration of a pollutant at a point (x, y) downwind from a source is proportional to the rate of emission (Q). Further, it is inversely proportional to the wind speed (\bar{u}), and to the parameters σ_y and σ_z . Also, it can be shown that the maximum ground level concentration of a gaseous pollutant is inversely proportional to the square of the effective stack height.

Many solutions of the above equation are now available which predict the ground level concentration of pollutants, both for gaseous and particulate pollutants.

But most of such formulas are derived only for simpler cases of constant velocity, steady state, and constant diffusion coefficients, though the variation of wind and diffusion coefficient with height is a recognised fact. It may be noted, that all point source models fail if there is a weak and variable wind. The models are also inadequate for inversion layers.

32 Air Pollution

On the other hand, the concentration of pollutants may be determined solving Fick's Law numerically considering the wind profile, lapse rate, gustiness, topography, variation of diffusion coefficient or other relevant factors. Of late, the numerical technique has been employed in some investigations. However, it is important to note that success of the method depends on the appropriate consideration of influencing factors while solving the Fickian equation. To this end, the work of Hino deserves a special mention. The author has proposed a method for estimating smoke diffusion over a complicated topography.

It is important that mean wind speed at the centreline of the plume be used in dispersion equations. Where data at least at stack height, is not available, upper wind speeds may be calculated by the following equation

$$\bar{u}_h = \bar{u}_1 \left(\frac{h}{z_1} \right)^n \quad (3.11)$$

where subscripts represent two different heights. Smith recommends $n = 0.25$ for unstable and $n = 0.50$ for stable conditions.

Nearby buildings may affect plume behaviour by causing mechanical turbulence which may bring portions of the plume to ground level near the stack. The effect is most noticeable when wind speeds are high and the stack is downwind of the building. The effect may be overcome by using the conservative thumb rule which states that stacks 2 to $2\frac{1}{2}$ times the height of nearby buildings will clear the building wake.

Irregular terrain may also affect ground level concentrations. The dispersion formulas usually used are meant for flat, level areas. Generally, rough terrain promotes dispersion.

3.6.4 Dispersion Models

Mathematical approaches have been made to the dispersion of pollutants in the atmosphere and atmospheric dispersion models have been developed based on Fick's molecular diffusion equation and on statistical theory.

For instantaneous point source, dispersion models have been developed based on Fick's molecular diffusion equation and on Sutton's statistical concepts.

For continuous point source, the dispersion models are based on plume behaviour, eddy diffusion, wind speed, and amount of dilution etc., because the continuous emission of pollutants results in a plume which is carried by the wind speed and spreads by the intensity of turbulence eddy.

Based on stability classification in the field of atmospheric diffusion the three well-known models in use are:

1. Pasquill model
2. ASME model
(American Society of Mechanical Engineers' model)
3. McElroy model

Details of these models are given in IS: 8829.

3.6.5 Wind Tunnel Method

The available formulas for estimating or predicting the pollutants are usually obtained for uniform topographic and meteorological conditions. These difficulties led to the adoption of model study of what is popularly known as the wind tunnel method. This technique employs the method of similitude between the actual flow condition and that of the model in the wind tunnel.

In the case of a strong wind when turbulent mixing keeps the lapse rate almost adiabatic, it may not be difficult to obtain the usual geometric and dynamic similitude. But the simulation of scales and intensities of turbulence, and of variation of mean wind velocity with height, is extremely difficult. Conventional tunnels fail in correct prediction when the atmospheric lapse rate controls the plume behaviour, as the temperature within the model is essentially isothermal. Many works are in progress to develop suitable simulation methods which will in turn promise the applicability of the wind tunnel technique in solving the atmospheric diffusion problem.

3.6.6 Stack Height

The height of the stack and the height of rise of the plume above the stack play a major role in the ground level concentration expected on the down wind side.

The actual stack height (H) is easy to determine while effective stack height (H_e) is quite difficult to estimate with any degree of accuracy. The increased stack height is considered to diffuse the pollutants better. Immediately above the stack, the rise of pollutant is proportional to the emission velocity of gases and to the temperature differences between the gases and the surrounding atmosphere.

For a given stack height, the concentration at ground level decreases with increase in wind velocity. However, there is a 'critical velocity' when the ground concentration attains its maximum value which is given by

$$C_m = \frac{M \cdot K}{H^2} \sqrt[3]{\frac{1}{V \cdot AT}} \quad (3.12)$$

where,

C_m = Maximum concentration of pollutants on ground level

H = Height of the stack

M = Mass of the pollutant gases discharged per unit time

V = Volume of the pollutant gases discharged per unit time

AT = Difference in temperature of stack gases and surrounding air

K = Constant which accounts for factors such as

1. Horizontal and vertical mixing of pollutants in the air;
2. settling velocity of polluting substances;
3. discharge characteristics of the gases from stack.

34 Air Pollution

It has been reported that in the direction of wind, the maximum concentration is attained at a distance X_m ranging from 10–40 times the stack height.

The empirical formula for the stack height emitting maximum concentration of pollutants is given as follows

$$C_{\max} = \frac{AFMm}{H^2} \left(\frac{n}{V \cdot t} \right)^{1/3} \quad (3.13)$$

where,

C_{\max} = Maximum concentration of pollutants

A = Coefficient, depends upon atmospheric condition

= 200 for Indian conditions

F = Coefficient, depends upon dust precipitation efficiency, ranges from 0.8 to 0.95

M = Quantity of flue gases in g/s

m = Coefficient depends upon velocity of flue gases

H = Height of stack or chimney in m

n = Number of emitting sources

V = Volume of gases leaving the chimney in cu. m/s.

t = Difference in temperature between flue gases and atmospheric temperature at the top of the stack.

This formula is in use in the USSR and coefficients are being derived for Indian conditions.

Example

A factory uses 2,00,000 litres of furnace oil (specific density 0.97) per month. If for one million litres of oil used per year, the particulate matter emitted is 3.0 tonnes per year, SO_2 emitted is 59.7 tonnes per year, NO_x emitted is 7.5 tonnes per year, hydrocarbons emitted are 0.37 tonnes per year, and carbon monoxide emitted is 0.52 tonnes per year, calculate the height of the chimney required to be provided for safe dispersion of the pollutants.

As per emission regulations (July 1984) part I published by the Central Board for Prevention and Control of Water Pollution, New Delhi, the chimney height is to be calculated according to the formula:

$$H = 74(Q)^{0.27} \quad (3.14)$$

where

Q = particulate matter emission in tonnes per hour

H = height of chimney in metres

The particulate emission is equal to 3.0 tonnes per million litres of oil per year. Consumption of oil is equal to

$$\begin{aligned} 2,00,000 \times 12 &= 24,00,000 \text{ l/year} \\ &= 2.4 \text{ million l/year} \end{aligned}$$

Therefore,

$$\begin{aligned} \text{Total particulate emission} &= 2.4 \times 3.0 = 7.2 \text{ tonnes per year.} \\ &= \frac{7.2}{300 \times 24} \text{ tonnes per hour (assuming 300} \\ &\quad \text{working days and 24 hours per day).} \end{aligned}$$

Now,

$$\begin{aligned} H &= 74 \left(\frac{7.2}{300 \times 24} \right)^{0.27} \\ &= 11.47 \text{ m} \end{aligned}$$

The height of the chimney for effective dispersion of SO_2 is to be calculated as per the formula $H = 14(Q)^{0.3}$ (as given in Sec. 19.5 under guidelines for minimum stack height)

where,

Q = SO_2 emission in kg/h

H = Height of chimney in metres

$$\begin{aligned} Q \text{ in the example} &= 59.7 \times 2.4 = 144 \text{ tonnes per year} \\ &= 20 \text{ kg/h} \end{aligned}$$

Therefore $H = 14(20)^{0.3} = 34.4 \text{ m}$

So, adopt a height of 34.4 metres.

(Since the emission of SO_2 is much more than that of NO_x , CO, and Hydrocarbons, the calculation of stack height is done based on SO_2 emission data only).

3.6.7 Scope for Future Work

Many experimental and theoretical works are in progress to investigate the complicated atmospheric structure, both near the ground and well above the ground. Many interesting meteorological features, from the point of atmospheric pollution, are now recognised. In view of the importance of many meteorological factors and topographical features besides the stack geometry, and also in view of the increased available memory capacities of digital computers, there is no reason why we should not take up the numerical method of solution of the problem of atmospheric pollution thereby avoiding any unnecessary simplification of the problem.

QUESTIONS

1. List out the meteorological factors influencing air pollution.
2. Explain the role of meteorological elements in the dispersion of air pollutants in the atmosphere.
3. Explain the cause and effects of 'inversion of atmosphere'.
4. Explain stable and unstable atmosphere and inversion of the atmosphere.
5. Explain the following atmospheric conditions:
 - (a) Super-adiabatic
 - (b) Sub-adiabatic

36 Air Pollution

- (c) Neutral
- (d) Inversion

How do they influence the dispersion of pollutants in the atmosphere?

6. With the help of neat sketches, explain the working of
 - (a) Wind speed recorder
 - (b) wind direction recorder.
7. Define a wind rose. Explain the importance of wind roses in air pollution studies.
8. Explain the terms
 - (a) Environmental lapse rate
 - (b) Adiabatic lapse rate
 - (c) Wind rose
9. Describe with neat sketches, how different atmospheric conditions give rise to different kinds of plumes.
10. Write explanatory notes on
 - (a) Dispersion models
 - (b) Estimation of plume rise
 - (c) Wind tunnel techniques for the study of atmospheric diffusion
 - (d) Calculation of stack height
11. Write short notes on:
 - (a) Inversions
 - (b) Wind rose
 - (c) Lapse rate
 - (d) Atmospheric dispersion
 - (e) Plume behaviour

4

Industrial Plant Location and City Planning

4.1 Introduction

Till now the factors considered for locating a new industrial plant were the availability of raw materials, power, water supply, transportation facilities, labour and the market. Now one more critical factor has to be considered by the plant management, i.e., the factor of air pollution control. In fact, the neglect of this aspect of air pollution control in the past by many large industries has proved to be a costly error, for today they are facing heavy damage claims, litigation and the necessity of taking control measures after several years of operation.

4.2 Factors to be Considered for Industrial-plant Location

While selecting a site from the point of air pollution control, the following factors should be taken into consideration to avoid costly control measures, improve public relations, and prevent litigation.

1. Existing levels of air contaminants
2. Potential effects on the surrounding area
3. Meteorological factors and climate
4. Topographical features
5. Clean air available
6. Planning and zoning

4.2.1 Existing Levels of Air Contaminants

If the new plant is to be located in an area which is already industrialised, it is a good practice to undertake a pre-operational survey to know the existing levels of contaminants, under prevailing meteorological conditions. This type of survey gives an idea regarding the nature of pollution due to existing industries, i.e., whether the existing level of pollution is high, medium or low. The results of such a survey, with respect to known operational data on the magnitude of contemplated emissions from the new sources, would provide information on the extent to which waste products

38 Air Pollution

could be safely discharged into the atmosphere without resulting in too much contamination.

A preliminary survey is also useful if the site to be chosen is located in a rural or suburban area. This is because, the area under consideration may be exposed to exotic pollution, i.e., contamination from distant sources. It is important to determine what those concentration levels are in relation to the proposed scale of operations. Suspended particulate matter, sulphur dioxide, fluorides, etc., may be transported over great distances from large industrial complexes to predominantly rural areas. The rural community may tolerate the existing conditions until a new plant commences activities in the immediate neighbourhood.

4.2.2 Potential Effects on the Surrounding Area

Another important factor from the point of site selection is to have a knowledge of the specific effects of the major pollutants likely to be discharged into the atmosphere in relation to the population and land use of the area surrounding the site. For example, whether the pollutants will have any effect on the health of the people, whether it causes damage to the vegetation, and whether it affects the farm animals in that area, is to be considered. A rural and predominantly agricultural area is more affected by fluorides and sulphur dioxide than an urban population. This is because certain pollutants are more toxic and harmful to vegetation and animals than to people. Hydrogen sulphide has little effect on vegetation but is obnoxious and even dangerous to human life in comparatively low concentrations.

Thus it is seen that the effects of contaminants likely to be discharged from the proposed industrial plant is important, in particular, from the point of its effects on human health, animals and damage to crops. Incidentally, it is also important from the point of keeping good public relations, as any polluting industry leads to number of public complaints and litigations.

4.2.3 Meteorological Factors and Climate

The prime factors which have to be considered in order to minimise air pollution problems by site selection are the climate and meteorology of the location under consideration. It is important to know the prevailing wind direction, wind speed, and factors favourable for stable atmosphere, i.e., inversion conditions. The dispersive ability of the air at each possible site has to be determined. This can be done on the basis of the average values for wind movement and inversion conditions. Wind roses for each possible site have to be constructed and studied. Meteorological factors should be favourable for the air to dilute the pollutional load down to acceptable levels of contamination. These factors have been discussed in Chapter 3 in greater detail.

The ideal site for location of an industry is a level terrain in a region

where the average wind speed is of the order of 16 km/h or more and where temperature inversions rarely occur. Also, it is always better, if a populated town or agricultural land is not on the downwind of the proposed site. Further, if possible, the plant site area should be large enough so that maximum ground level concentration of pollutants downwind, occur well within factory premises rather than on surrounding private property.

Areas where prolonged subsidence inversions occur frequently should be avoided for location of industries, if alternate sites are available. Individual valleys where prolonged conditions of stable atmosphere are frequent should be critically examined. Industrialisation of these areas must be minimised.

4.2.4 Topographical Features

Air movement is greatly influenced by the topography in the neighbourhood of the site under consideration, like valleys, mountains, etc. In fact, we have to give more attention to air pollution control in valley sites than in level terrain, especially when the average wind velocity is less than 16 kilometres per hour.

The location of industries in valleys, mountainous areas, and undulating terrain present difficult problems from the point of air pollution control. The air pollution disasters in Meuse Valley, Belgium, and at Donora, Pennsylvania, (Chapter 5) are good examples. These episodes occurred in valley areas, due to prolonged inversion conditions for four or five days. They resulted in many cases of illness and loss of life. If an industrial plant is located at the bottom of a narrow valley with mountains rising fairly steeply on either side, the situation becomes very critical. Probably, it will be one of the worst site conditions one can think of.

For efficient dilution and dispersion of air pollutants in the atmosphere, it is important to know the prevailing wind direction, wind velocity, degree of turbulence, etc. The probable influence of other industrial plants and tall buildings in the vicinity should also be considered. The eddies produced by nearby buildings may cause erratic dispersion of the gas. This must be taken into consideration in the design of stacks. Stacks must be tall enough so that the effective height of the plume will permit the air pollutants to be dispersed safely in the atmosphere. The necessary data may be obtained by micro-meteorological investigations, and conducting air pollution surveys.

In general, the adverse influence of topography and weather factors in relation to pollution control should be carefully considered, and critically examined, before selecting a site for a new industrial plant.

4.2.5 Clean Air Available

The requirement of many industrial processes for supplies of clean air introduces another important aspect of air pollution into the problem of site selection. For example, industries requiring clean air for manufacture are factories dealing with the manufacture of transistors, electronic components, antibiotics, and vaccines. Also, clean air is required for cooling the reactors

40 Air Pollution

of atomic energy plants, since, if polluted air were used, the impurities present would become radioactive and their escape into the atmosphere would create a hazard. In these cases, location of industries in areas of heavy air pollution will add materially to the cost of cleansing the air.

4.2.6 Planning and Zoning

Proper planning and zoning of industrial areas and residential areas can play an important role in the control of air pollution. Residential areas and certain heavy industries should not be located too close to each other. It is always better to have a green belt between industrial areas and residential areas. The concerned municipal authorities should encourage the creation of green belt. If there are any municipal laws and regulations regarding this aspect, they should be strictly enforced.

Recently, scientists have identified a dozen species of trees which have a capacity to absorb industrial pollutants from the air. Many of these trees grow in our country. For example, it has been reported that tamarind and margosa trees are capable of absorbing dust and gas from the atmosphere polluted by cement factories, chemical industries and quarries. This fact has been established by laboratory studies carried out jointly by the Toxicological Research Centre and the National Institute of Botanical Research, Lucknow. Therefore, growing suitable trees is an important way of solving the problem of air pollution.

In zoning of land for industrial use, direction, speed, and frequency of prevailing winds should be given due consideration. The topography of the area should also be considered.

In general, while considering each possible site for the location of a plant, the site advantages vis-a-vis the cost of control of air pollutants should be carefully investigated.

4.3 City Planning

Today, we are seeing many cities developing in a very haphazard manner. They are now paying the price for the failure to plan for future systematic and homogeneous development. Smoke, dust, fumes, odours and poor zoning practices have spoiled fine residential areas and created ugly sights in central parts of some cities. In many cases, good residential areas in the heart of the cities have degenerated into slums.

One of the basic principles of country planning is, it must be flexible, continuous and adopted to the local requirements. While planning, the growth trend in population and industries that may come up in the near future should be taken into consideration. Residential, commercial and industrial areas must be properly planned. Prime importance must be given for locating sufficient number of public parks and gardens, for they act as

lung spaces, especially in the industrial cities. Also, there must be sufficient provision for traffic lanes and parking facilities.

For the proper growth and development of a city, a zoning law is required. The residential, commercial and industrial zones in and around the city must be clearly defined by the competent authority. And of course, the regulations must be strictly implemented. It is a sad commentary that many cities with good zoning restrictions have nullified them by granting exemptions whenever sufficient pressure has been brought to permit land use not in conformity with the regulations.

Every city or town requires its own zoning ordinance according to the local conditions. As land usage changes, the zoning regulations must be modified to meet new conditions. Satellite towns bordering a city must also be subjected to zoning to provide for orderly growth.

However, there can be no successful solution to the problem of eliminating ugly and unattractive sights in cities like black dense smoke given out by buses and lorries, until air pollution is properly controlled. As such, in many cases zoning and pollution control measures must go hand in hand, and must be carried out on a regional rather than a local basis. This requires active cooperation between adjoining cities, as well as between states.

In fact, in some western countries, the effects of air pollution on future zoning are being taken into considerations by city planners.

For effective control, larger air pollution zoning districts, or even interstate contracts or international agreements, may be required depending on meteorological conditions. For example, to prevent or reduce the effects of acid rain, this may be necessary.

Following are some of the measures that can be taken for air pollution control by planning and zoning:

1. Decentralisation of industry
2. Creation of a green belt between industry and receptor areas
3. Regulations over automobile exhausts
4. Traffic control
5. Creation of smokeless zones in selected areas by limiting industries and residences in those zones to the use of certain specific smokeless fuels
6. Prohibiting use of volatile fuels.

QUESTIONS

1. What steps can be taken in the planning stages of a city or an industry to avoid the problem of air pollution to the maximum possible extent?
2. Explain how topography and climate affect the planning of a town with reference to location of industries from the point of atmospheric pollution.
3. Explain the importance of proper planning and zoning of industrial and residential areas from the point of air pollution control.

42 Air Pollution

- 4. List of factors that should be taken into consideration while selecting a site for an industry from the point of minimising air pollution.**
- 5. Write short notes on**
 - (a) Exotic pollution**
 - (b) Green belt**
 - (c) Zoning law**
 - (d) City planning**

5

Effects of Air Pollution on Human Health

5.1 Introduction

Air pollution is one of the greatest environmental evils. The air we breathe has not only life-supporting properties but also life-damaging properties. Under ideal conditions the air we inhale has a qualitative and quantitative balance that maintains the well-being of man. But when the balance among the air components is disturbed, or in other words, if it is polluted, it may affect human health.

An average man breathes 22,000 times a day and takes in 16 kg of air each day. It far exceeds the consumption of food and water. It has been estimated, that a man can live for five weeks without food and five days without water, but only for five minutes without air.

All the impurities in the inhaled air do not necessarily cause harm. Depending upon the chemical nature of the pollutants, some may be harmful when present in the air in small concentrations and others only if they are present in high concentrations. The duration of exposure of the body to polluted air is also an important factor. Therefore, the prime factors affecting human health are:

1. Nature of the pollutants
2. Concentration of the pollutants
3. Duration of exposure
4. State of health of the receptor
5. Age group of the receptor

Generally speaking, susceptibility to the effects of air pollution is great among infants, the elderly, and the infirm. Those with chronic diseases of the lungs or heart are thought to be at great risk. Pre-school and school children appear to be both sensitive and specifically reactive to air pollution health effects. Another point to be noted is that the effect of air pollution on human health is worst during the winter season, when pollution levels reach a climax.

An objectionable odour, visibility reduction, eye irritation or vegetation damage are useful guides to the likelihood or severity of health effects. A grey pall over a city or an industrial area can have a depressing effect and impair the enjoyment of life. There is no doubt, however, that the urgency

44 Air Pollution

with which steps are taken to improve air quality will depend very much on how serious the risk of ill health from air pollution is thought to be.

Table 5.1 gives some of the disastrous air pollution events in the world.

Table 5.1 *Air Pollution Episodes*

S. No.	Month and year	Place	Mortality
1.	December, 1930	Meuse Valley (Belgium)	63
2.	October, 1948	Donora (Pennsylvania)	20
3.	November, 1950	Poza Rica (Mexico)	22
4.	December 1952	London	4000
5.	November, 1953	New York	220
6.	January, 1956	London	1000
7.	December, 1957	London	750
8.	December, 1962	London	700
9.	January, 1963	New York	300
10.	November, 1966	New York	168
11.	December, 1984	Bhopal (India)	2000

5.2 Mechanism of Action of Air Pollutants

The effects of air pollution on human health generally occur as a result of contact between the pollutants and the body. Normally, bodily contact occurs at the surfaces of the skin and exposed membranes. Contact with exposed membranous surfaces is of utmost importance because of their high absorptive capacity compared to that of the skin. Air-borne gases, vapours, fumes, mist, and dust may cause irritation of the membranes of the eyes, nose, throat, larynx, tracheo-bronchial tree and lungs (Fig. 5.1).

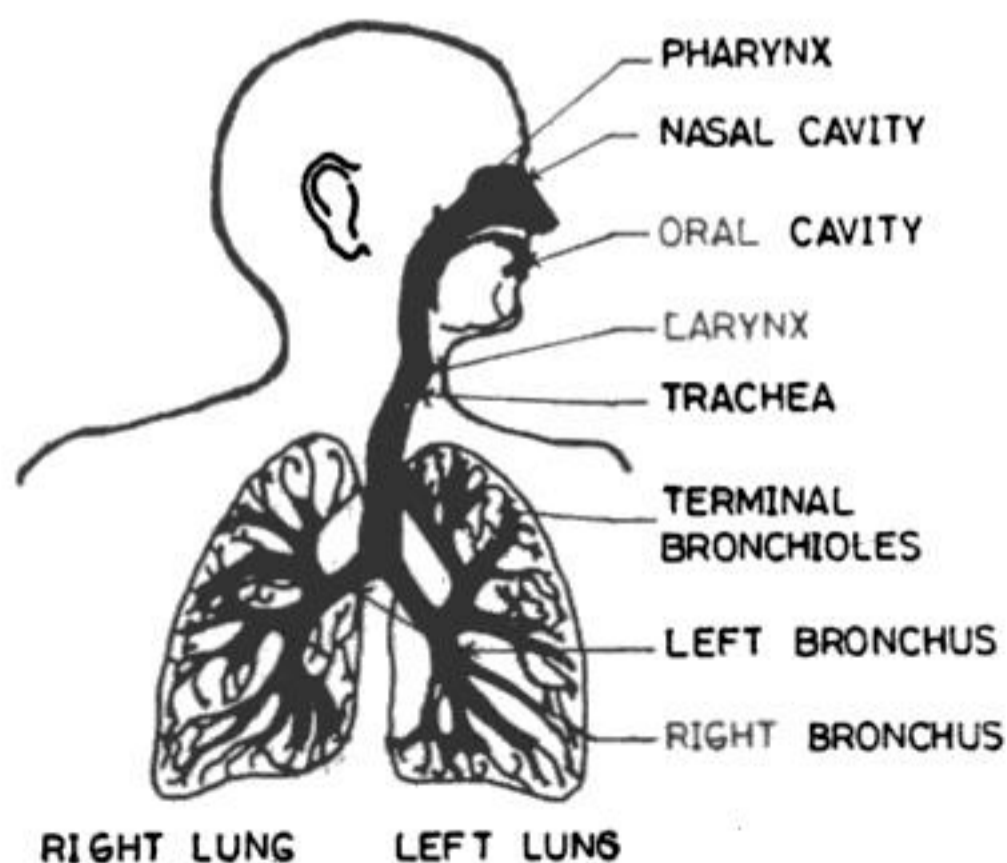

Fig. 5.1 *Human respiratory system.*

Some irritants even reach the mucosa of the digestive tract. The details of the mechanism involved is beyond the scope of this book, as greater attention has been given to the engineering aspects.

5.3 Health Effects

1. Eye Irritation.
2. Nose and throat irritation.
3. Irritation of the respiratory tract.
4. Gases like hydrogen sulphide, ammonia and mercaptans cause odour nuisance even at low concentrations.
5. Increase in mortality rate and morbidity rate.
6. A variety of particulates particularly pollens, initiate asthmatic attacks.
7. Chronic pulmonary diseases like bronchitis and asthma, are aggravated by a high concentration of SO_2 , NO_2 , particulate matter and photochemical smog.
8. Carbon monoxide combines with the haemoglobin in the blood and consequently increases stress on those suffering from cardiovascular and pulmonary diseases.
9. Hydrogen fluoride causes diseases of the bone (fluorosis), and mottling of teeth.
10. Carcinogenic agents cause cancer.
11. Dust particles cause respiratory diseases. Diseases like silicosis, asbestosis, etc., result from specific dusts.
12. Certain heavy metals like lead may enter the body through the lungs and cause poisoning.

5.3.1 Effect of Radioactive Fallout

The biological effect of radiation may be somatic or genetic damage. In somatic damage, the exposed individual is affected, while in genetic damage the future generations become the victims.

Radioactive fallout from testing of nuclear weapons causes:

- (a) Cancer
- (b) Shortening of life span
- (c) Genetic effects or mutation

One significant point we have to note about the effect of radioactive fallout is, it causes long range effects affecting the future of man and hence the future of our civilization.

5.4 Investigation of Health Effects of Air Pollutants

Three methods are available for determining the effect of various pollutants on people. They are:

1. Experimental exposures of men and animals
2. Clinical studies
3. Epidemiology

The experimental exposure of different types of animals under controlled conditions to various concentrations and dosages of air pollutants, can give valuable information regarding the mode of action of a pollutant and its effects. Of course, results must be subjected to rigorous statistical analysis. But the main problem here is, the extrapolation of results to human population.

Experimental exposures of men should be limited to concentrations and dosages of pollutants that will not result in serious illness. Types of effects noticed and measured include detection of odour, irritation of eyes, nose and throat, change in pulse rate, breathing frequency, reduction in physical activity and many other physiological responses.

Clinical studies mainly involve observations made on subjects who are or were exposed to atmospheric pollutants under uncontrolled conditions. Studies of truck drivers, traffic policemen, factory workers and other occupational groups may give valuable information. Also, patients visiting physicians to complain of symptoms supposedly caused by living in polluted areas may upon observation yield clinical data of great importance. Further, information has been collected by the follow up of the acute air pollution episodes. The data collected has indicated a relationship between air pollution and disease, particularly pulmonary disease.

In epidemiological studies, the relationships between the distribution of specific diseases in a human population and the factors that determine the distribution are found out. For example, one may compare morbidity records, mortality records, hospital admissions, absenteeism, and other health related data from various geographical areas with levels of air pollutants in the same areas to determine a correlation, if any. To avoid misinterpretation, the population under study must be carefully observed for smoking habits, occupational exposures, and any other factor that might prejudice the results of the study.

5.5 Specific Pollutants

5.5.1 Sulphur Dioxide

Sulphur dioxide is an irritant gas which affects the mucous membranes when inhaled. Under certain conditions, some of the air-borne sulphur dioxide gas is oxidised to sulphur trioxide. Each of these two gases, in the

presence of water vapour or water, forms sulphurous and sulphuric acid respectively. Sulphur trioxide is a very strong irritant, much stronger than sulphur dioxide, causing severe bronchospasms at relatively low levels of concentration.

5.5.2 Carbon Monoxide

Carbon monoxide has a strong affinity for combining with the haemoglobin of the blood to form carboxyhaemoglobin, COHb. This reduces the ability of the haemoglobin to carry oxygen to the body tissues. CO has about two hundred times the affinity of oxygen for attaching itself to the haemoglobin, so that low levels of CO can still result in high levels of COHb. Carbon-monoxide also affects the central nervous system. It is also responsible for heart attacks and a high mortality rate.

5.5.3 Oxides of Nitrogen

Of the seven oxides of nitrogen known to exist in the ambient air, only two are thought to affect human health. These are nitric oxide (NO) and nitrogen dioxide (NO₂). While some questions remain about haemoglobin reactions with oxides of nitrogen, there is no positive evidence that nitric oxide exposure is a health hazard associated with community air pollution.

Nitrogen dioxide is known to cause occupational disease. Among occupations with NO₂ hazards are the manufacture of nitric acid, exposures of farmers to silage that has had high nitrate fertilisation, electric arc welding, and mining utilising nitrogen compounds as explosives. It is estimated that eye and nasal irritation will be observed after exposure to about 15 ppm of nitrogen dioxide and pulmonary discomfort after brief exposures to 25 ppm of nitrogen dioxide.

5.5.4 Hydrogen Sulphide and Mercaptans

Hydrogen sulphide is a foul smelling gas. It is well known for its rotten egg like odour. Exposures to hydrogen sulphide for short periods can result in fatigue of the sense of smell.

Other sulphur compounds that are of interest in air pollution mainly because of their strong odours are methyl mercaptan (CH₃SH) and ethyl mercaptan (C₂H₅SH). But it has been reported that at the concentrations at which they are odour nuisances, they have no other effect on human health. In fact, mercaptans are often added to natural or manufactured gas supplies so that leakage of gas will be noticed.

5.5.5 Ozone

Ozone is a gas that has an irritant action in the respiratory tract, reaching much deeper into the lungs than the oxides of sulphur.

5.5.6 Fluorides

Fluorides present in air, range from those which are extremely irritant and

48 Air Pollution

corrosive like hydrogen fluoride to relatively non-reactive compounds. But, fluorine is a cumulative poison even under condition of prolonged exposure and in sub-acute concentrations.

5.5.7 Lead

The main source of lead in urban atmospheres is the automobile. It creates urban concentration of inorganic lead of about $1-3 \mu\text{g}/\text{m}^3$, with high values in areas of heavy traffic. Inorganic lead acts as an agent which causes a variety of human health disorders. The effects include gastro-intestinal damage, liver and kidney damage, abnormalities in fertility and pregnancy, and mental development of children gets affected.

5.5.8 Hydrocarbon Vapours

Some of the hydrocarbon vapours in the atmosphere have health implications. The effect of formaldehyde is primarily irritating. It is a major contributor to eye and respiratory irritation caused by photochemical smog.

5.5.9 Carcinogenic Agents

Carcinogenic agents are responsible for cancer. For example, the poly-cyclic organic compound, 3, 4-benzpyrene. The origin of these compounds is in the incomplete combustion of hydrocarbons and other carbonaceous materials. They are also reported to be present in exhaust discharges from I.C. engines. In addition to poly-cyclic organic compounds, it has been found that some aliphatic hydrocarbons are also carcinogenic.

5.5.10 Insecticides

Insecticides are not only harmful for insects but also poisonous for man, e.g., DDT (Dichloro diphenyl trichloroethane). They can affect the central nervous system and may attack other vital organs. In fact, DDT has been found in mother's milk in western countries and even in our own country. Hence, the use of DDT has been banned in the USA. The United Nations Environment Programme (UNEP) has warned against the undesirable effects of indoor spraying of DDT. It has also been reported that indoor spraying affects domestic livestock.

According to a study conducted at the Industrial Toxicology Research Centre, Lucknow (India), the accumulation of pesticides in the environment due to their growing use for agricultural purposes can also cause premature labour and abortion, due to high concentration of pesticides in the body of expectant mothers.

5.5.11 Radioactive Isotopes

The important radioactive isotopes that may reach ambient air are Iodine 131, Phosphorous 32, Cobalt 60, Strontium 90, Radium 226, Carbon 14,

FOR REFERENCE PURPOSES ONLY



You have either reached a page that is unavailable for viewing or reached your viewing limit for this book.

50 Air Pollution

because clinico-immunological studies have not been done on asthmatics. Hence, further investigations and clinical studies are required to find the real cause for the high incidence of asthma among the people of Bangalore city.

Also, some industrial operations may add to the allergens. Industrial operations like cotton milling, fur processing, hair processing, feather processing, flour milling, jute processing, leather processing, wood working and tobacco processing, may be included under this category.

Although industrial operations contribute to the problem of air-borne allergens, they are primarily due to a natural origin. Some persons have been found to be allergic to sulphur dioxide. Finely divided cobalt and beryllium in the form of its compounds are also found to be allergic. Both cause lung disease. The commercial fur dye, paraphenylenediamine is an allergic agent capable of causing dermatitis in addition to bronchial asthma.

Factories processing the castor bean for the extraction of oil, discharge a powdery material into the air that is a strong allergen. This material has been the cause of bronchial asthma in people living near those factories.

5.6 Major Disasters

Several disastrous episodes have focussed attention upon air pollution as a health hazard. They have attracted attention because of illness and loss of life. The episodes have always occurred under extraordinary meteorological conditions and most of them were due to 'inversion phenomena'.

5.6.1 Meuse Valley (Belgium)

The first episode of 'modern' times was the disaster in Belgium's Meuse Valley. In December, 1930, an anticyclone (high pressure area) blanketed Belgium, resulting in fog and temperature inversion in Meuse Valley. In a 24-kilometre length, with hills 80–120 m high on either side, there are many industrial plants. Important among them are steel works, power plants, coke ovens, sulphuric acid plants, glass factories, zinc smelters and a fertiliser plant. Because of a thermal inversion, various pollutants got trapped in the valley. After three days of abnormal weather many people became ill, and about 60 died. The number of deaths was considered to be about 10.5 times the expected number for an equivalent period of time and season under ordinary circumstances. The symptoms were cough, throat irritation, shortness of breath (respiratory tract irritation), nausea, and vomiting. The illness affected people of all ages and both sexes. But older people with chronic heart or respiratory disease suffered the highest death rate. Even cattle were killed. After careful consideration of all the gases and aerosols that were discharged into the air from this industrial valley, it was believed that only an irritant air pollutant could have caused the illnesses and deaths, and it was probably a mixture of sulphur dioxide gas and

sulphurtrioxide aerosol. Other air pollutants, viz., fluorides (from glass factories), zinc particulates, etc., were considered to have played only a minor role in the disaster.

5.6.2 Donora (USA)

Donora, Pennsylvania, lies about 45 km south of Pittsburgh in a horseshoe-shaped valley on the Monongahela River, with steeply rising hills on each side of the river. Anti-cyclonic weather conditions characterized by little or no air movement, temperature inversion and fog occurred for a period of four days in October, 1948. The industries present in 1948 were a steel mill, zinc plant, and sulphuric acid plant. Out of a population of 14,100 people, 43% became ill and 10% were severely affected. Twenty persons died. The fatal cases were confined to elderly persons, 13 of whom had histories of heart or respiratory disease. Symptoms included irritation of eyes, nose, and throat, cough, headache, vomiting, and respiratory irritation. According to an observer, during those four days, "everything was black with gas and soot; one could even taste it". It was concluded that the illness was probably due to the combined action of two or more of the air contaminants namely sulphur dioxide, together with oxidation products and particulate matter.

5.6.3 London

London, situated in Thames Valley, experienced its worst air pollution episode due to fog from December 5 to December 9, 1952. The 'killer-smog' began on December 4 as a high pressure area created a subsidence inversion over southern England. A white fog formed in the London area. Because of the extensive use of coal (sulphur content 1.5%) as fuel for space heating and electricity production, the particulate and sulphur dioxide levels in the atmosphere increased. The white fog became a black fog. Smoke concentrations during the fog were found to be five times greater than those found at other times. The average concentration of sulphur dioxide in the atmosphere during the episode was about six times the usual level.

During the period, the high pressure area become stationary. The build up of pollutants combined with fog, resulted in practically zero visibility. By December 6, pollutants were sufficiently concentrated to cause deaths. According to one observer, "one could not see one's hand in front of one's face—a white shirt collar became almost black within 20 minutes." The symptoms were cough, nasal discharge, sore throat, irritation of eyes and bronchi, and sudden attacks of vomiting.

Most of the people who died were old and those who had histories of chronic bronchitis, asthma, broncho-pneumonia and other lung or heart disease. Younger people exposed to the outside atmosphere were also affected. The fog lifted on December 9.

This London disaster of 1952 caused 4000 deaths. The excessive mortality and morbidity were caused by the irritation of the respiratory tract by contaminants in the fog and these contaminants were probably derived from coal and its products.

FOR REFERENCE PURPOSES ONLY



You have either reached a page that is unavailable for viewing or reached your viewing limit for this book.

FOR REFERENCE PURPOSES ONLY



You have either reached a page that is unavailable for viewing or reached your viewing limit for this book.

54 Air Pollution

of about an hour will not exceed about 1.5 ppm (2.8 mg/m³). But, as pointed out earlier, cigarette smoking produces intermittent exposures, whereas city air pollution is more constant. The other substances in cigarettes to which the body is exposed include carcinogens, aldehydes, hydrogen cyanide, lead, etc.

The effects of cigarette smoking are more important than effects of air pollution, as far as causing lung cancer or chronic pulmonary disease in the whole population is concerned. But, when both factors are present, they naturally have more than additive effect. This means that cigarette smokers are at unusual risk, if they live in areas with substantial air pollution and that the effects of air pollution on chronic pulmonary diseases are more likely to occur in cigarette smokers.

5.7.2 Domestic Pollution

Cooking and home heating appliances can generate a group of air pollutants (carbon monoxide, sulphur oxides, oxides of nitrogen, soot, and oily aerosols) whose health effects have commonly been overlooked. During periods of still weather and low winds, the dispersal of such domestic pollutants will be impaired. Generally, oxidants are about half as concentrated within buildings in polluted areas as they are outside, but carbon monoxide and nitric oxide are likely to occur at similar concentrations indoors and outdoors. Hence, if smoking or cooking occurs indoors, exposures to carbon monoxide and nitrogen oxides may be quite high.

5.7.3 Occupation

Many people are exposed to common air pollutants in their occupations. For example smoke, dust, carbon monoxide, sulphur dioxide and lead. The traffic policeman, the automobile mechanic, and the truck driver in a big city may all have substantial exposures to carbon monoxide and lead in association with their occupations. Therefore, such individuals have an unusually high risk from exposure to community air pollution.

QUESTIONS

1. Explain with a neat sketch the mechanism of action of air pollutants on human beings.
2. What are the harmful effects of polluted air on human beings?
3. Explain briefly the various methods adopted for determining the health effects of air pollutants on people.
4. What are the harmful effects of the following on human beings?
 - (a) Sulphur dioxide
 - (b) Carbon monoxide
 - (c) Hydrocarbons
 - (d) Insecticides

FOR REFERENCE PURPOSES ONLY



You have either reached a page that is unavailable for viewing or reached your viewing limit for this book.

6

Effects of Air Pollution on Animals

6.1 Introduction

Interest in the effects of air pollution on animals has generally developed as a corollary to the concern about its influence on human health. Most of the information concerning the natural exposure of animals to air pollution is contained in the reports of some major air pollution disasters e.g., Donora, London and Poza Rica. Recently, considerable information has been reported from medical research laboratories which describes the results of experimental exposure of small animals to various air pollutants. Animals used for laboratory research work were mice, rabbits, rats, guinea pigs and monkeys.

6.2 Air Pollution Effects on Farm Animals

The process by which farm animals get poisoned is entirely different from that by which human beings exposed to polluted atmospheres are poisoned. In case of farm animals it is a two-step process:

1. Accumulation of the air-borne contaminant in the vegetation and forage
2. Subsequent poisoning of the animals when they eat the contaminated vegetation

In case of human beings working in polluted atmospheres in factories, the concern is for the harmful substances that are directly inhaled, whereas in the case of the farm animals, the danger obviously is not in inhaling the polluted air, but rather the ingestion of forage which has been contaminated with pollutants like fluorine from the air.

The three pollutants responsible for most livestock damage are fluorine, arsenic and lead. These pollutants originate from industrial sources or from dusting and spraying.

6.2.1 Fluorine

Of all farm animals, cattle and sheep are the most susceptible to fluorine

toxicosis. Horses appear to be quite resistant to fluorine poisoning. Poultry are probably the most resistant to fluorine, of all farm animals.

Symptoms of Acute Fluorine Poisoning

Lack of appetite, rapid loss in weight, decline in health and vigour, lameness, periodic diarrhoea, muscular weakness and death, characterize the acute form of fluorine poisoning. It may also result in considerable increase of bone fluorine. But acute poisoning due to fluorides is unlikely in a majority of the cases.

Symptoms of Chronic Fluorine Poisoning

Fluorine is a cumulative poison under conditions of continuous exposure to sub-acute doses. Fluorine is also a protoplasmic poison. It has a marked affinity for calcium and interferes with normal calcification. Animals have been reported to be more resistant than humans to dental mottling. Cattle and sheep are the most frequently affected animals. Teeth in the process of formation are easily affected. Hence tooth symptoms are a sensitive and unique criterion of chronic fluorosis. Excessive wearing of incisor and molar teeth may occur at high levels of fluorine intake.

Bone lesions may develop at any age. A bony overgrowth may be observed on the leg bones, jaw bones and ribs. Their appearance indicates that there has been a high fluoride intake over a long period. Lameness may occur as a result of this overgrowth on the leg bones. This may be followed by stiffness of joints. Effects of fluorides on skeletal structures are usually of a permanent nature.

Symptoms of advanced fluorosis include lack of appetite, general ill-health due to malnutrition, lowered fertility, reduced milk production and growth retardation. The symptoms developed in other species such as rabbits, horses and poultry are similar to those in cattle and sheep, i.e., mottling, staining and wearing of the teeth, bony overgrowths on the skeleton, stiffness and lethargy and general ill-health from malnutrition and starvation.

While diagnosis of chronic fluorine poisoning is done, one has to be careful. This is because drinking water supplies may contain unduly high levels of fluorides. Also, mineral supplements may contribute appreciable amounts of fluorine to the diet. Hence, a check of all possible sources must be made when investigating fluorosis.

6.2.2 Arsenic

Arsenic occurs as an impurity in many ores and in coal. It has been reported to cause poisoning of livestock near various industrial processes and smelters. Just like most industrial air contaminants, arsenic may spread over a considerable area from a stack source. Arsenic in dusts or sprays on plants can lead to poisoning of cattle.

Symptoms of Acute Arsenic Poisoning

In acute cases the symptoms are severe salivation, thirst, vomiting, uneasiness, feeble and irregular pulse and respiration. The animal stamps, lies down and gets up. There is diarrhoea, and the faeces have a garlic odour and are sometimes bloody. The ears become cold, the body trembles and develops abnormal temperature and convulsion. Death may occur in few hours or days.

Symptoms of Chronic Arsenic Poisoning

Arsenic appears to have a depressing effect upon the central nervous system. The animal becomes dull, and exhibits a lack of appetite, with a resulting weight loss. Also, there may be chronic cough and diarrhoea may occur continuously. There may be thickening of the skin, anaemia and abortion or sterility. Chronic poisoning can result in eventual paralysis and death.

Tolerance Limits

Arsenic as well as its soluble compounds are extremely poisonous. It has been reported that sheep have been poisoned by as little as 0.25–0.50 g of arsenic daily, whereas cattle and horses may tolerate 1.3–1.9 g daily. It has also been reported from laboratory experiments, that 10 mg of arsenic per kilogram of body weight per day has produced chronic arsenic poisoning in guinea pigs. A detailed investigation of the effects of arsenic poisoning on farm animals is necessary to establish standard tolerance limits.

6.2.3 Lead

Lead contamination of the atmosphere takes place on account of various industrial sources such as smelters, coke ovens and other coal combustion processes. Lead is also used in dust and sprays containing lead arsenate.

Symptoms of Acute Lead Poisoning

In case of acute lead poisoning the onset is sudden and the course relatively short. Prostration, staggering and inability to rise are prominent symptoms. The pulse is always fast but weak. Some animals may fall suddenly, stiffen the legs and have convulsions. There is complete loss of appetite, paralysis of the digestive tract and diarrhoea. Other nervous symptoms in cattle are grinding of the teeth and rapid chewing of the cud.

In case of horses, it may result in complete loss of appetite, nervous depression, lethargy and death.

Symptoms of Chronic Lead Poisoning

Chronic lead poisoning has been observed frequently in horses that have been grazing on forage near smelters, lead mines, and in orchards that have been sprayed. Paralysis of the muscles of the larynx and difficulty in breathing are the main symptoms. Convulsions may occur from the paralysis of

the throat, and the difficulty in breathing may be unusually severe and persistent, during and after exercise.

Tolerance Limits

Lead is a cumulative poison. Therefore, the continuous ingestion of even very small daily doses will be finally as effective as one toxic dose. Hence in case of slight contamination death can occur after many months and in case of severe contamination death can occur within 24 hours.

It has also been reported that inadequate calcium in diet increases the retention of lead in the animal body. Low-calcium diets may result in lead storage of as much as five times as compared to that found in animals that receive sufficient amounts of calcium. However, extra quantities of calcium above the amount considered sufficient, will not offer additional protection against poisoning.

6.3 Pets and Pollution

It is reported that pollution is now beginning to affect pets and domestic animals in Tokyo and other smog affected cities. Canine patients are found to be suffering from bronchitis, asthma and lack of appetite. Many dogs also suffer from coughs, nose and throat diseases due to increasing air pollution. It is interesting to note that the average life of pets in Japan is seven to eight years, whereas in developing countries, they enjoy a life span of 12 to 13 years. It is also reported that some chemical laboratories in universities in Japan and some industrial firms keep canaries to warn the staff of poisonous gas in the air. Once the canaries cease to sing, the people know that something is wrong!

6.4 Exposure to Ionising Radiation

Radioactive fallout from nuclear bomb testing in the atmosphere results in ionising radiation, which has biological effects. The effects of radiation on animals are qualitatively similar to those in human beings. The effects may be either acute radiation effect or delayed long-term effect.

Symptoms of acute radiation injury develop within a period of hours to weeks, following exposure. Only fallout occurring close to the nuclear bombs test site can produce acute radiation effects, because of the high degree of radiation received by the animal body.

The long term effects are:

1. Cancer (including leukaemia)
2. Shortening of life span
3. Genetic or mutation effect

FOR REFERENCE PURPOSES ONLY



You have either reached a page that is unavailable for viewing or reached your viewing limit for this book.

FOR REFERENCE PURPOSES ONLY



You have either reached a page that is unavailable for viewing or reached your viewing limit for this book.

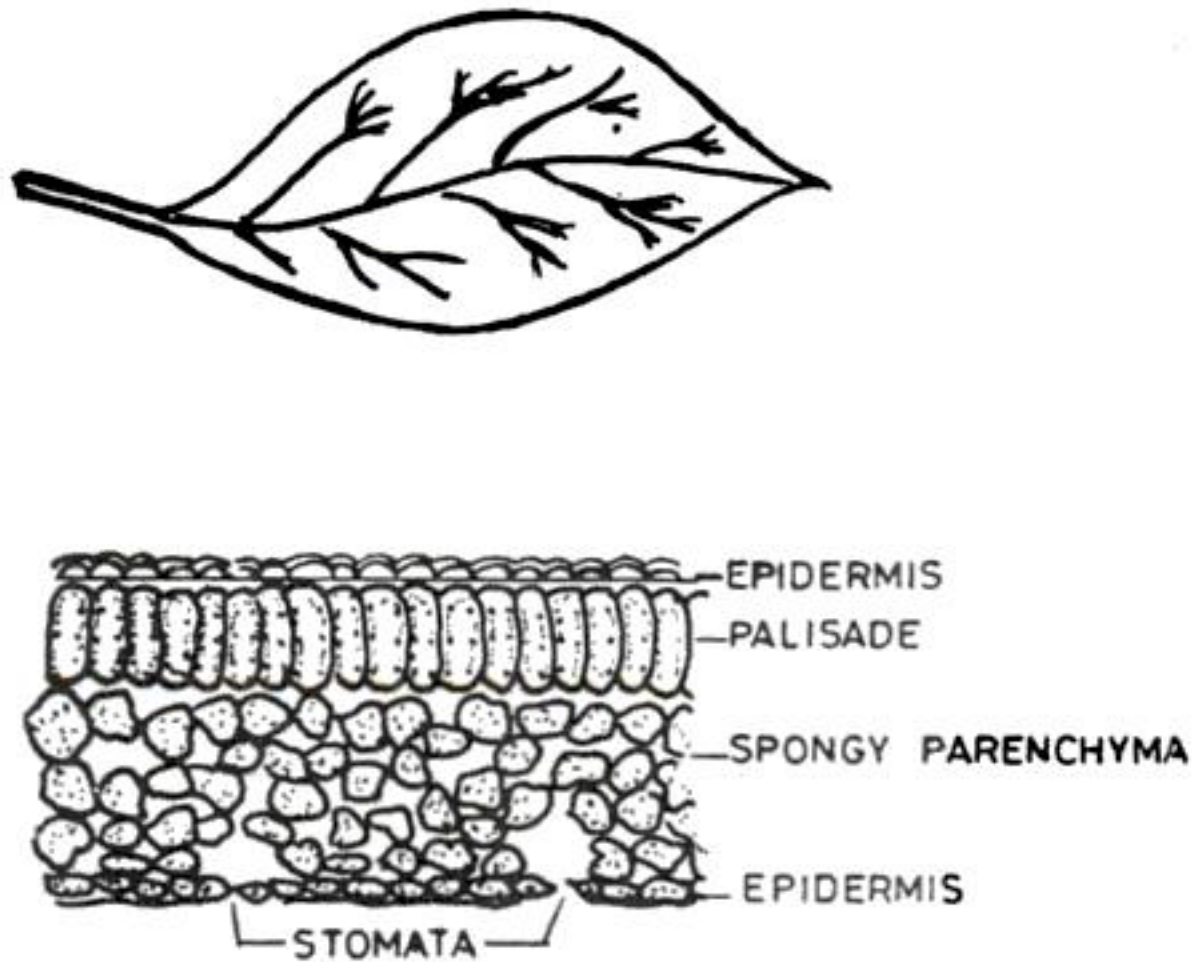

Fig. 7.1 *Cross-section of a leaf*

7.2.1 Effect of Environment on Plants

The primary factor which controls gas absorption by the leaves is the degree of opening of the stomata. When the stomata are wide open, absorption is maximum and vice versa. Consequently, the same conditions that enhance the absorption of the gas (CO_2 for photosynthesis), predispose the plant to injury (by absorbing a pollutant gas like SO_2). The conditions that cause the stomata to open are high light intensity (especially in the morning hours), high relative humidity, adequate moisture supply to the roots of the plant and moderate temperatures.

Most plants close their stomata at night and are therefore much more resistant at night than in the day time. But some plants like the potato, which do not close their stomata at night are as sensitive in the dark as in the light.

7.3 Air Pollutants Affecting Plants

1. Sulphur dioxide
2. Fluoride compounds (like hydrogen fluoride)
3. Ozone
4. Chlorine
5. Hydrogen chloride
6. Nitrogen oxides (NO , NO_2 , etc.)
7. Ammonia
8. Hydrogen sulphide
9. Hydrogen cyanide
10. Mercury
11. Ethylene

FOR REFERENCE PURPOSES ONLY



You have either reached a page that is unavailable for viewing or reached your viewing limit for this book.

FOR REFERENCE PURPOSES ONLY



You have either reached a page that is unavailable for viewing or reached your viewing limit for this book.

FOR REFERENCE PURPOSES ONLY



You have either reached a page that is unavailable for viewing or reached your viewing limit for this book.

66 Air Pollution*Nitric Oxides*

Injury to plants due to nitric acid vapours has been observed near factories handling large amounts of this acid. The effects include brown margins and brownish-black spots on the leaves. Concentrations of about 25 ppm will cause these effects. Nitrogen oxides are important in photochemical reactions which cause smog.

Ammonia

Ammonia is a gas of intermediate toxicity. It is interesting to note that ammonia and hydrogen chloride almost have about the same toxicity.

Hydrogen Cyanide

Hydrogen cyanide is used to fumigate green houses and trees in orchards for pest control. Sometimes this fumigation injures the vegetation.

Ethylene

Ethylene causes injury to leaves of sensitive plants. The effects are epinasty, curling, chlorosis, leaf abscission, and growth retardation.

Herbicides

Injury to sensitive vegetation may be caused in the field through careless or uncontrolled use of herbicides and pesticides. It has been reported that weedy grain fields have sometimes been sprayed when there was wind, and the spray has been carried for several kilometres in sufficient concentration to injure crops like cotton and tomatoes. Many other plants which have exhibited symptoms of injury under similar conditions are roses, cabbage, pepper, grapes and tobacco.

7.5.5 Smog

London type smog is thought to be essentially a sulphur dioxide problem. But the gaseous constituents as well as the aerosols need further evaluation.

The Los Angeles type smog is now fairly well understood, but the actual compounds that cause these effects are still unknown. Two types of smog injury to vegetation have been recognized in Los Angeles, one due to gases (smog gas) and the other due to deposition on the leaves of fog droplets (smog fog). The smog causes characteristic leaf lesions which are quite different from those produced by other pollutants, including ozone, which may be a constituent of the smog. It also causes some 'invisible' injury.

7.6 Sensitivity of Plants to Air Pollutants

The sensitivity of plants to air pollutants is conditioned by many factors.

FOR REFERENCE PURPOSES ONLY



You have either reached a page that is unavailable for viewing or reached your viewing limit for this book.

FOR REFERENCE PURPOSES ONLY



You have either reached a page that is unavailable for viewing or reached your viewing limit for this book.

FOR REFERENCE PURPOSES ONLY



You have either reached a page that is unavailable for viewing or reached your viewing limit for this book.

8

Economic Effects of Air Pollution

8.1 Introduction

Air pollution damage to property is a very important economic aspect of pollution. In the United States of America, Great Britain, France and many other European countries, this problem has been investigated in detail and successful attempts have been made to translate observable air pollution damage into terms of economic impact. Air pollution damage to property covers a wide range—corrosion of metals, soiling and eroding of building surfaces, fading of dyed materials, rubber cracking, spoiling or destruction of vegetation, effects on animals, as well as interference with production and services. Another important economic effect of air pollution is deterioration of works of art. In our country today there is an urgent need to investigate and study this problem in detail and express the damage to property in economic terms, as very little work has been done in this direction so far.

8.2 Mechanism of Deterioration in Polluted Atmospheres

Air pollutants cause damage to materials by five mechanisms:

1. **Abrasion:** Solid particles of sufficient size and travelling at high velocities can cause abrasive action. Also, large sharp edged particles imbedded in fabrics can accelerate wear.

2. **Deposition and Removal:** Solid and liquid particles deposited on a surface may not damage the material itself but it may spoil its appearance. However, the removal of these particles may cause some deterioration. Although a single washing or cleaning may not cause noticeable deterioration, frequent cleaning ultimately does.

3. **Direct chemical attack:** Some air pollutants react directly and irreversibly with materials to cause deterioration. For example, the bleaching of marble by sulphur dioxide, the tarnishing of silver by hydrogen sulphide and the etching of a metallic surface by an acid mist.

4. **Indirect chemical attack:** Certain materials absorb some pollutants and get damaged when the pollutants undergo chemical changes. For

FOR REFERENCE PURPOSES ONLY



You have either reached a page that is unavailable for viewing or reached your viewing limit for this book.

FOR REFERENCE PURPOSES ONLY



You have either reached a page that is unavailable for viewing or reached your viewing limit for this book.

FOR REFERENCE PURPOSES ONLY



You have either reached a page that is unavailable for viewing or reached your viewing limit for this book.

dioxide. This is because, it is about this date onwards in history that chemical methods were introduced for manufacturing paper. Apparently, the small amounts of metallic impurities in 'modern' paper accelerate the conversion of absorbed sulphur dioxide to sulphuric acid, in the presence of moisture. The sulphuric acid content of some papers has been found to be as high as one per cent, which makes the paper extremely brittle. It has been found that exposure of books and writing paper to sulphur dioxide in concentrations 2-9 ppm for 10 days made them brittle and decreased their folding resistance.

8.4.7 Glass and Ceramics

Although glasses and enamels are especially resistant to the chemical action of air pollutants, it has been observed that during a long exposure for three years, porcelain enamels showed a change in their surface appearance. Moisture and atmospheric pollution by acidic substances seems to have played a major role in surface degradation.

Fluorides, especially hydrogen fluoride, are capable of attacking a wide range of ceramic materials and glass through their ability to react with silicon compounds. In the past, window glasses in areas near synthetic fertiliser and enamel plants have been rendered opaque through the action of fluorides. However, the concentrations required to produce this type of damage are far in excess of those necessary to kill sensitive vegetation. Restrictions imposed on emission limits of fluorides by legislation in many countries has actually eliminated this type of effect except perhaps in occasional localized situations. Hence, fluoride damage to materials appears to be an insignificant economic effect.

8.4.8 Electronics Industry

Particulate matter and gaseous pollutants have been constant sources of trouble to the electronics industry. Many kinds of electronic components and equipment have been damaged. Lower-power (millivolts, microamperes) electrical contacts, which are used in numerous electrical devices, are particularly sensitive components. Air pollutants cause thin insulating film to develop on contacts resulting in open circuits and malfunctioning of the equipment. Sulphur dioxide and hydrogen sulphide tarnish copper and silver contacts by producing sulphide films. These pollutants even cause gold-silver bonded contacts to fail. Atmosphere particles can settle on contacts and prevent intimate surface contact when closed. If the particles contain corrosive components, direct chemical action can occur.

Contact problems have made engineers make a special effort to specify appropriate contact materials for various applications. For example, one can think of a computer that controls the operations in a chemical plant. The computer can cease to function because of an inexpensive tarnished electrical contact. The resulting time loss could run into thousands of rupees. Therefore, because of the critical nature of contact materials,

FOR REFERENCE PURPOSES ONLY



You have either reached a page that is unavailable for viewing or reached your viewing limit for this book.

FOR REFERENCE PURPOSES ONLY



You have either reached a page that is unavailable for viewing or reached your viewing limit for this book.

FOR REFERENCE PURPOSES ONLY



You have either reached a page that is unavailable for viewing or reached your viewing limit for this book.

Colosseum in Rome, and the San Marco Basilica in Venice, Italy, show signs of decay, possibly due to air pollution. In France, it is reported that environmentalists have removed statues from the exterior of cathedrals and replaced them with copies. Similarly, ancient temples and buildings in industrial areas of Japan are facing the hazards of atmospheric pollution. Paintings, books, fabrics, antique costumes and other art objects have suffered damage.

Of course, it is impossible to make adequate substitution or compensation for the losses suffered by works of art. They are irreversible losses. It is impossible to estimate the losses in economic terms for these intangible assets. In some cases it is possible to preserve them, by applying special preservatives. But, they are not always successful. Sensitive art objects displayed inside buildings can be placed in hermetically sealed containers. Air conditioning can also be used as a protective measure.

8.7 Cost Estimates

As already pointed out, it is difficult to estimate the costs of air pollution with regard to its damaging effects. Certain costs such as loss to agriculture have been estimated, but many of the economic effects of pollution are indirect or hidden and thus difficult to determine. For example, additional cleaning costs on account of soiling of clothes, medical expenses of the affected people, and damage to works of art. In spite of these difficulties some estimates have been made, especially in countries like the U.S.A., Great Britain, and France. It is estimated that damage amounting to \$ 3 million has been done to crops in the Los Angeles region every year since 1953. Unfortunately in our country, so far this type of estimate has not been made for various cities and states. It has to be done immediately, so that people can be alerted about the invisible economic impact of air pollution. One available example of this type of statistics is given in Section 8.7.2.

8.7.1 Evaluation of Damage—Basis for Calculation

The damage to materials due to air pollution can be calculated according to:

- (1) Type of object damaged (plants, metal-work, etc.)
- (2) Extent or degree of damage (partial or total)

The type of pollutant causing damage should also be considered. An example of evaluation of damage due to air pollution is as follows:

8.7.2 Financial Loss Due to Air Pollution in West Bengal

Air pollution is causing a financial loss of Rs. 38 crore to West Bengal annually, according to a survey conducted by the Smoke Nuisance Department of the state government. The survey was made in Greater Calcutta and the districts for over five years.

FOR REFERENCE PURPOSES ONLY



You have either reached a page that is unavailable for viewing or reached your viewing limit for this book.

FOR REFERENCE PURPOSES ONLY



You have either reached a page that is unavailable for viewing or reached your viewing limit for this book.

FOR REFERENCE PURPOSES ONLY



You have either reached a page that is unavailable for viewing or reached your viewing limit for this book.

1. Statistical studies

They are of utmost importance to establish the basic data, e.g., size and frequency of sampling. Statistical studies use the basic principle of probability, i.e., they do not give absolute results but only indicate the percentage probability that a given series of data will be accurate within certain limits.

2. Size of samples

The samples should be large enough to make analysis possible.

3. Changes in the sample during and after sampling.

This is one of the fundamental causes of error. These possibilities should always be borne in mind by the investigator so that he can try to avoid such serious sources of error.

4. Continuous and intermittent sampling

An automatic, continuous recording apparatus is becoming more and more popular. Intermittent sampling can also be made, but continuous recording is always preferable. Many of the continuous recording instruments combine the operations of sampling and analysis.

5. Sampling of volatile constituents

In this case, to avoid the sources of error, it is better to carry out sampling with large volumes of air.

6. Sampling of particulates

Here errors may be introduced due to agglomeration or breaking up of particulate matter. In order to eliminate the sources of error,

- (a) Sampling should be carried out under conditions which are as isokinetic as possible.
- (b) A gas stream should be sampled as far as possible in the same direction and at the same speed itself, but never counter-current.
- (c) The collecting surface should be as close as possible to the source of the gas stream. To avoid reducing the efficiency of sampling, deposits and condensation should not be allowed to form on the walls of sampling vessels. Hence this condition (c).

7. Sampling of waste gas

Here, difficulties are encountered due to high temperature, lack of uniformity in the composition of gas flow, and difference in speed due to disturbances. Hence to avoid error, the gas stream should be sampled at several points and maximum number of samples should be taken, to get the average value.

8. Sampling in the open air

Here difficulties arise due to,

- (a) High dilution of the pollutants dispersed in air
- (b) Consequent need to collect large number of samples
- (c) Difficulty of sampling under isokinetic conditions

Therefore, to minimise the error of sampling, continuous recording instruments should be used, and samples should be collected at various places.

FOR REFERENCE PURPOSES ONLY



You have either reached a page that is unavailable for viewing or reached your viewing limit for this book.

FOR REFERENCE PURPOSES ONLY



You have either reached a page that is unavailable for viewing or reached your viewing limit for this book.

FOR REFERENCE PURPOSES ONLY



You have either reached a page that is unavailable for viewing or reached your viewing limit for this book.

weight, absorption in aqueous solutions is sometimes incomplete. In such cases, it is preferable to use bottles of known volume for collecting under a pressure reduced to 200 mm Hg or even less.

To do this, the absorbent solution chosen is first introduced into the bottle and the pressure is then reduced. Then the sample is admitted until the internal and external pressures are equal and the container is shaken continuously so as to ensure maximum absorption.

This method is suitable, for sampling the oxides of N₂.

Plastic Containers

Special polythene bags are commonly used for collecting and transporting large volumes of air. These bags have the advantage that they can be used for successive analysis of small fractions of the sample taken. Moreover, polythene is inert with respect to many substances including SO₂ and formaldehyde. On the other hand, plastic bags are not suitable for collecting and storing aerosol suspensions, because of the possible generation of electrostatic charges, as a result of which the aerosols tend to move towards the walls and condense on them. Plastic bags have been widely used for grab sampling and sample storage before analysis.

Samplers for Mass Spectrometric Analysis

Sampling for mass spectrometric analysis can be carried out in various ways. For example, by compressing the gas sample in a pressure flask so as to concentrate a large quantity of gas in a small volume, or by filling evacuated containers.

9.5 Duration of Sampling Period

Two types of sampling are used in studies of air pollution. Short period or 'spot' sampling and continuous sampling for the evaluation of peak and average concentrations over definite time intervals. Spot samples are collected over periods varying from less than 30 minutes to several hours for specific, well defined purposes. The choice of sampling period depends upon the nature of the compound under study and its stability to oxidation, light or other factors such as sensitivity, accuracy and precision of the analytical method to be used for the measurement of pollutants. Short-sampling is useful for the random checking of pollution at many points. Such samples have only limited value because pollution levels fluctuate widely, depending on meteorological conditions, topographical features, and various factors associated with sources of pollution (e.g., mass rates of emission of pollutants from smoke stacks, the temperature, velocity and density of stack gases, the height of smoke stacks, the distribution of sources, and the down-wind distance from the sources to the points where the measurements are

FOR REFERENCE PURPOSES ONLY



You have either reached a page that is unavailable for viewing or reached your viewing limit for this book.

FOR REFERENCE PURPOSES ONLY



You have either reached a page that is unavailable for viewing or reached your viewing limit for this book.

FOR REFERENCE PURPOSES ONLY



You have either reached a page that is unavailable for viewing or reached your viewing limit for this book.

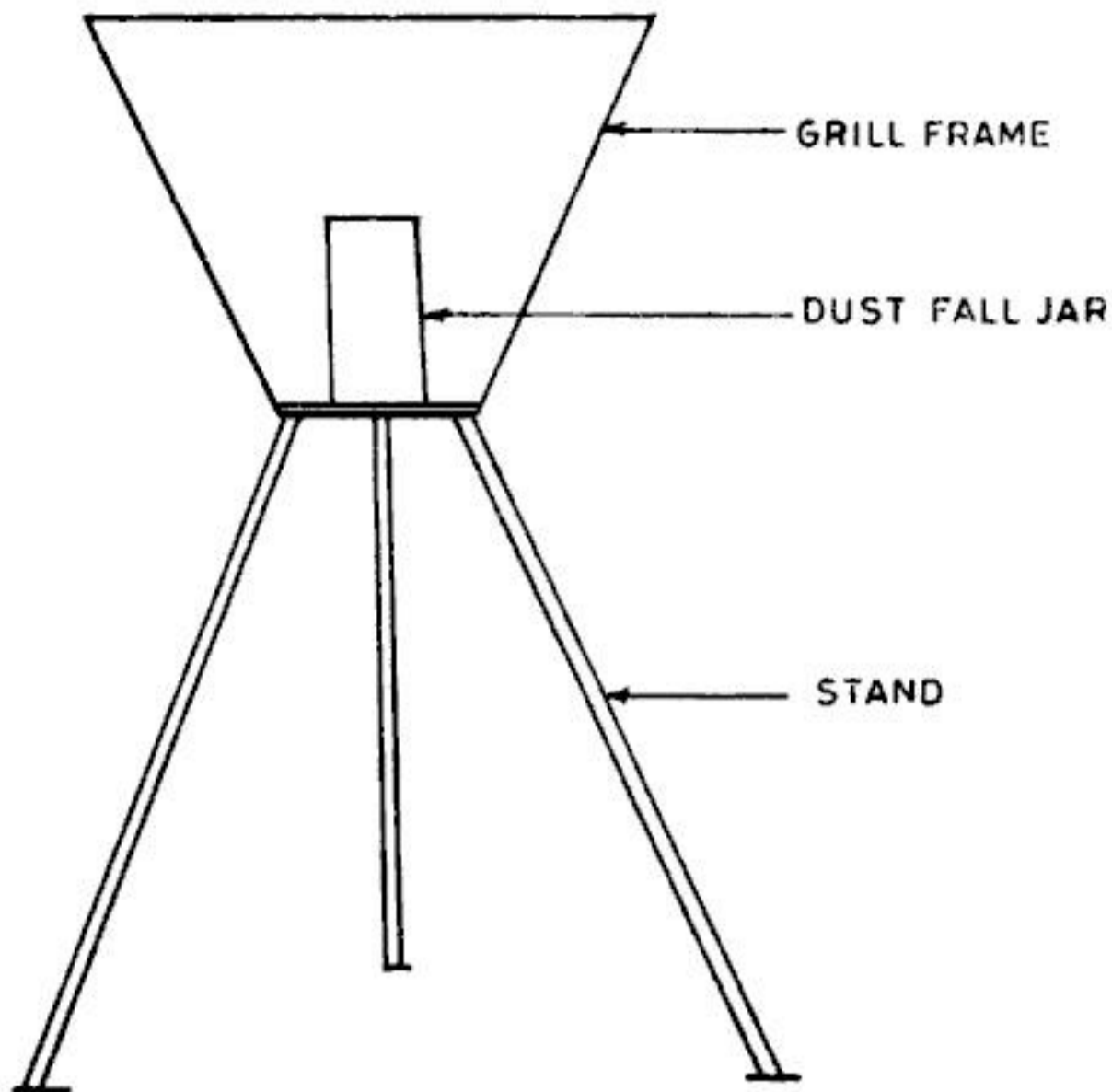

Fig. 9.2 *Dust fall jar*

given industry or industrial complex, containers may be placed as close as a few hundred metres apart. General considerations in site selections are:

1. The site should be free from overhead obstructions and away from interference by local sources such as an incinerator or chimney.
2. The mouth of the dust fall collector should be no less than 2.5 m and no more than 16 m above ground level, with a standard height of 6 m as recommended elevation.
3. When sampling in urban areas, the dust fall collector should be set no less than 10 stack lengths from an operating smoke stack and no closer to a vertical wall than the distance that provides a 30° angle from the sampler to the top of the wall or roof.

The results are affected by the shape and dimensions of the container. Therefore, results for particle fall for different areas cannot be compared unless the dimensions and design of the collectors, their location and other details are rigidly standardised.

The major advantage of dust fall sampling is probably the ease of procurement of 1–5 gram of weightable sample, on which a number of chemical and physical analysis can be performed. In addition, the method is simple and inexpensive and requires no electrical power or moving parts. It facilitates: (a) collection of dust that is representative of a given industry or community; (b) detection of process changes of a given industry; and (c) survey of a community to determine areas of high versus low levels of dust pollution. The disadvantages of the method include lack of precision and inability to

FOR REFERENCE PURPOSES ONLY



You have either reached a page that is unavailable for viewing or reached your viewing limit for this book.

FOR REFERENCE PURPOSES ONLY



You have either reached a page that is unavailable for viewing or reached your viewing limit for this book.

FOR REFERENCE PURPOSES ONLY



You have either reached a page that is unavailable for viewing or reached your viewing limit for this book.

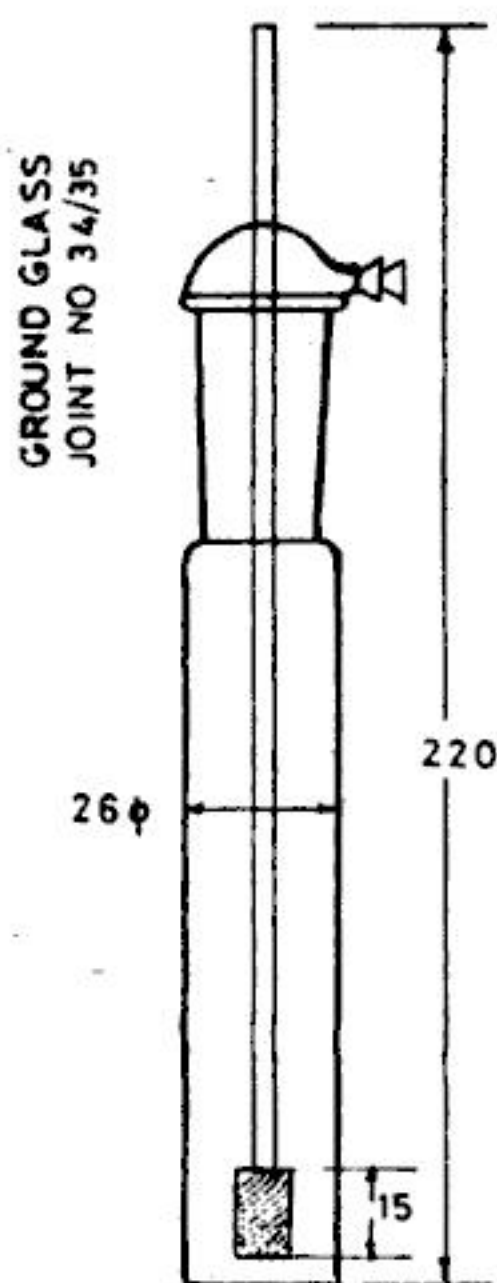

Fig. 9.4 Midget fritted impinger

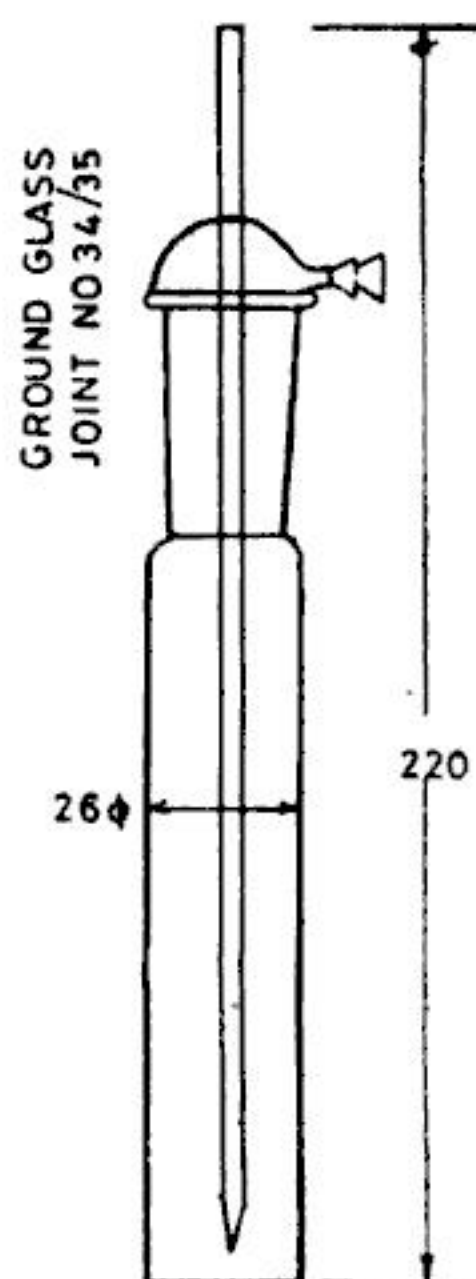

Fig. 9.5 Standard midget impinger

ALL DIMENSIONS IN MILLIMETRES

tend to fracture or separate into smaller particles at the high impact velocities attained, leading to the formation of many more fine particles than were present in the original sample.

9.7.4 Electrostatic Precipitation

Application of a potential difference of 12–30 kV across a sample airflow, so that actual ionisation of the gas volume takes place, leads to collisions between particles and ions to produce electrostatically charged particles. Subsequent passage of those charged particles through an electrical field results in their collection at an electrode whose charge is opposite to that of the particle. Collection of particles at nearly 100% efficiency occurs readily over a reasonable length of gas path with particles ranging in diameter from 10–0.2 μ .

The most important mechanism in the charging of particles whose diameter is greater than about 2 μ is bombardment by ions. For particles whose diameter is less than about 0.2 μ , the controlling mechanism is charging by ion diffusion or the motion of ions induced by thermal motion of the surrounding gas molecules. Both mechanisms are effective in the collection of particles whose diameter is 0.2–2.0 μ . Relatively high collection efficiencies (greater than 98%) are possible for many type of dusts and fumes of submicron size.

FOR REFERENCE PURPOSES ONLY



You have either reached a page that is unavailable for viewing or reached your viewing limit for this book.

FOR REFERENCE PURPOSES ONLY



You have either reached a page that is unavailable for viewing or reached your viewing limit for this book.

FOR REFERENCE PURPOSES ONLY



You have either reached a page that is unavailable for viewing or reached your viewing limit for this book.

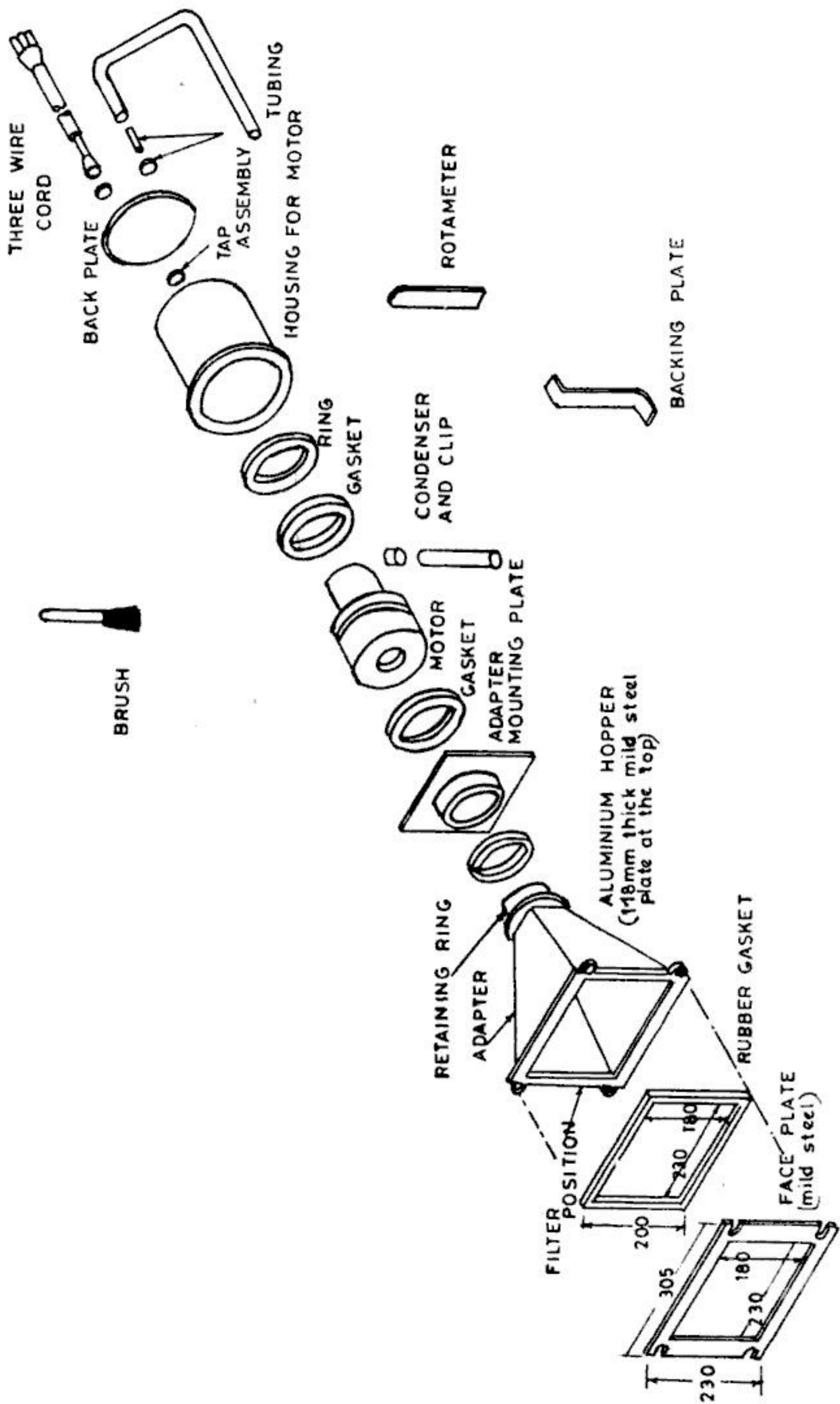

ALL DIMENSIONS IN MILLIMETRES

Fig. 9.7 Exploded view of typical high volume air sampler parts

FOR REFERENCE PURPOSES ONLY



You have either reached a page that is unavailable for viewing or reached your viewing limit for this book.

FOR REFERENCE PURPOSES ONLY



You have either reached a page that is unavailable for viewing or reached your viewing limit for this book.

FOR REFERENCE PURPOSES ONLY



You have either reached a page that is unavailable for viewing or reached your viewing limit for this book.

102 Air Pollution

standard or reference temperature and pressure. The standard pressure of 760 mm Hg and temperature of 0°C should be employed. Although correction to standard or reference gas conditions may not be justified for many local purposes owing to inherent technical errors or the limited accuracy of measurements, it is essential that temperature and pressure conditions be reported in all studies in which comparability and precision are desired.

Normally, the concentration of air pollutants is expressed in terms of milligrams per cubic metre (mg/m^3) or micrograms per cubic metre ($\mu\text{g}/\text{m}^3$).

Field Data to be Collected

During the sampling period, the data related to sample collection are to be collected and noted down in the field book. A model proforma is given in Table 9.3.

9.8.4 Determination of Mass Concentration

Equilibrate the exposed filter for twenty-four hours in the desiccator and then weigh. After they are weighed save the filters for chemical analysis.

The mass concentration of the suspended particulate is calculated using the formula.

$$C = \frac{(W_2 - W_1)}{V} \times 10^6 \quad (9.2)$$

where C = mass concentration of suspended particulates in $\mu\text{g}/\text{m}^3$

W_2 = final weight of the filter in grams

W_1 = initial weight of the filter in grams

V = total volume of air sample in m^3 at STP

10^6 = conversion of gm to μg

$$V = \frac{(Q_1 + Q_2)}{2} \times T \quad (9.3)$$

where Q_1 = initial flow rate in $\text{cu m}/\text{min}$

Q_2 = final flow rate in $\text{cu m}/\text{min}$

T = sampling time in min

9.8.5 Example

Average pressure of the day at station level = 712.59 mm of Hg

Average temperature = 30.6 °C or 303.6 °abs.

Actual sampling time = 24 h or 1440 min

Sampling rate = clean filter: 1.6 $\text{cu m}/\text{min}$

Filter after exposure = 1.5 $\text{cu m}/\text{min}$

Average = 1.55 $\text{cu m}/\text{min}$

Therefore volume of air sampled = Sampling rate \times sampling time

$$= 1.55 \times 1440$$

$$= 2232 \text{ cu m}$$

Correction for temperature and pressure:

$$\frac{PV}{T} = \frac{P_1V_1}{T_1}$$

FOR REFERENCE PURPOSES ONLY



You have either reached a page that is unavailable for viewing or reached your viewing limit for this book.

FOR REFERENCE PURPOSES ONLY



You have either reached a page that is unavailable for viewing or reached your viewing limit for this book.

FOR REFERENCE PURPOSES ONLY



You have either reached a page that is unavailable for viewing or reached your viewing limit for this book.

where,

\overline{PMR}_S = is the average pollutant mass emission rate from the stack
 \bar{C}_S = is the average stack concentration of the pollutant, and
 \bar{Q}_S = is the average volumetric stack gas flow rate.

Hence, the overall objective is to determine \overline{PMR}_S by measuring \bar{C}_S and \bar{Q}_S . The average volumetric stack gas flow rate, \bar{Q}_S is determined by measuring the average gas velocity, V_S and the area of the stack A_S .

$$\bar{Q}_S = \bar{V}_S \times \bar{A}_S \quad (9.5)$$

The basic equation to determine the velocity of flow inside the stack is given by Eq. (9.6.)

$$V_S = K_P \times C_P \left\{ \frac{T_S \times \Delta P}{P_S \times M_S} \right\}^{1/2} \quad (9.6)$$

where,

ΔP = is the velocity head, mm H₂O.

T_S = is the stack temperature °K.

P_S = is the absolute stack gas pressure, mm Hg.

M_S = is the molecular weight of the stack gas.

K_P = is the dimension constant.

C_P = is the pitot coefficient.

9.9.2 Selection of Sampling Location

The selection of the best sampling point is almost invariably a matter of compromise and individual judgement.

The sampling point should be as far as possible from any disturbing influence, such as elbows, bends, transition pieces, baffles or other obstructions. The sampling point, wherever possible should be at a distance 5–10 diameters down-stream from any obstructions and 3–5 diameters up-stream from similar disturbance.

Size of Sampling Point

Usually, there will not be any opening in the stack. Hence for collection of samples, an opening has to be made to an extent of accommodating the probes. The size of sampling point may be made in the range of 7–10 cm, in diameter. A flange may be riveted so that the opening may be closed during the non-sampling period.

Traverse Points

For the sample to become representative, it should be collected at various points across the stack. This is essential as there will be changes in velocity and temperature (hence the pollutant concentration) across the cross-section of the stack. Traverse points have to be located to achieve this. These points are to be located at the centre of each of a number of equal areas in the selected cross-section of the stack. The number of traverse points may be selected with reference to Table 9.4.

FOR REFERENCE PURPOSES ONLY



You have either reached a page that is unavailable for viewing or reached your viewing limit for this book.

FOR REFERENCE PURPOSES ONLY



You have either reached a page that is unavailable for viewing or reached your viewing limit for this book.

FOR REFERENCE PURPOSES ONLY



You have either reached a page that is unavailable for viewing or reached your viewing limit for this book.

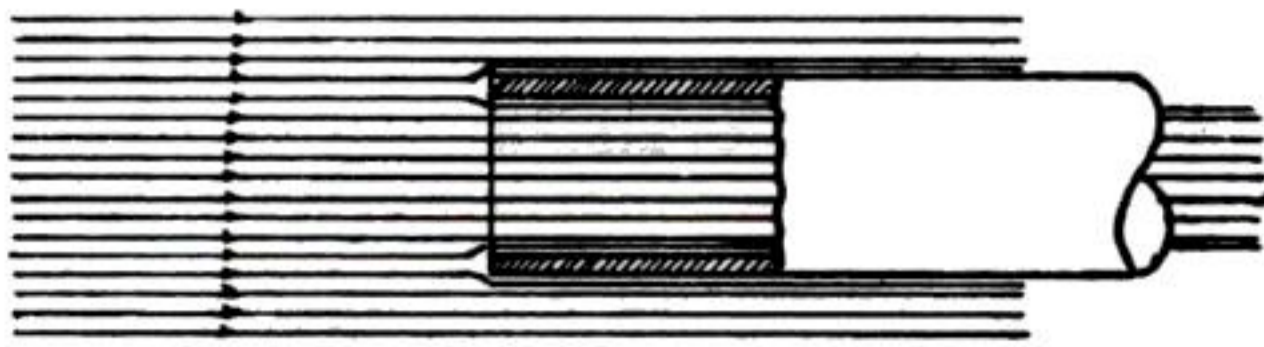

(a) ISOKINETIC SAMPLING

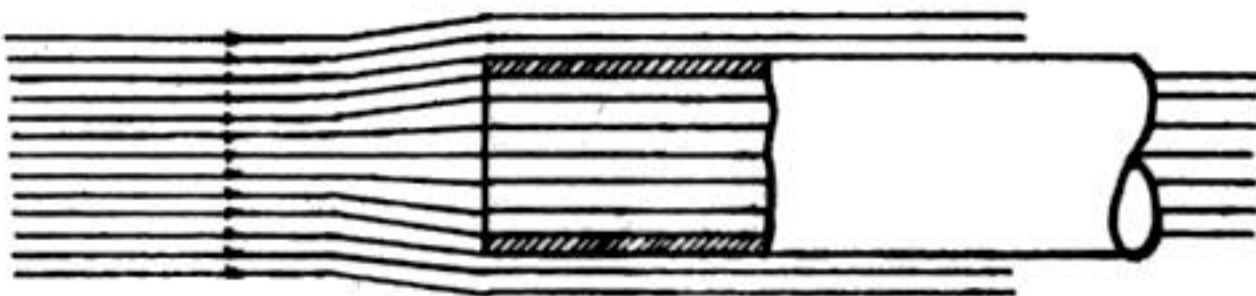

(b) FLOW RATE LESS THAN ISOKINETIC RATE



(c) FLOW RATE GREATER THAN ISOKINETIC RATE

Fig. 9.11 *Isokinetic sampling*

Determination of Moisture Content

The moisture content in the stack may be determined by any one of the following methods:

1. Wet bulb and dry bulb temperature technique
2. Condenser technique
3. Silica gel tube

The wet and dry bulb technique is used when the moisture content is less than 18% and dew point is less than 51°C and cannot be used for acid streams. As the moisture content in the stack is usually less than 18%, the wet bulb and dry bulb technique is being adopted.

9.9.5 Determination of Temperature

The temperature has to be measured across the cross-section of the stack at predetermined traverse points. The temperature probe is inserted into the stack and the readings are taken with the help of a pyrometer. Care should be taken in selecting the probe.

FOR REFERENCE PURPOSES ONLY



You have either reached a page that is unavailable for viewing or reached your viewing limit for this book.

FOR REFERENCE PURPOSES ONLY



You have either reached a page that is unavailable for viewing or reached your viewing limit for this book.

FOR REFERENCE PURPOSES ONLY



You have either reached a page that is unavailable for viewing or reached your viewing limit for this book.

FOR REFERENCE PURPOSES ONLY



You have either reached a page that is unavailable for viewing or reached your viewing limit for this book.

FOR REFERENCE PURPOSES ONLY



You have either reached a page that is unavailable for viewing or reached your viewing limit for this book.

FOR REFERENCE PURPOSES ONLY



You have either reached a page that is unavailable for viewing or reached your viewing limit for this book.

FOR REFERENCE PURPOSES ONLY



You have either reached a page that is unavailable for viewing or reached your viewing limit for this book.

FOR REFERENCE PURPOSES ONLY



You have either reached a page that is unavailable for viewing or reached your viewing limit for this book.

FOR REFERENCE PURPOSES ONLY



You have either reached a page that is unavailable for viewing or reached your viewing limit for this book.

10

Analytical Methods

10.1 Introduction

Since the aim of analysis in the special field of air pollution is to obtain information which can give an overall picture of the whole problem, it is evident that certain requirements should be satisfied as regards concordance between sampling and analytical techniques. These requirements are as follows:

1. The efficiency of the sampling device used should be known as accurately as possible
2. The sampling device chosen should cause the minimum of change in the composition of the various substances to be detected
3. The sampling method should supply the analyst with a quantity of pollutants within the quantitative limits called for by the sensitivity of the analytical technique to be used
4. The methods employed for determination should be as sensitive as possible

The various analytical methods require, in addition to a specialized and skilled technical staff, a special high precision equipment.

The methods used for analysis of atmospheric samples can be divided into three basic groups.

1. Chemical methods
2. Instrumental methods
3. Biological methods

10.2 Chemical Methods

- (a) Gravimetric method
- (b) Volumetric method
 - (i) Acidimetric and alkalimetric method
 - (ii) Oxidation and reduction method
 - (iii) Precipitation method
- (c) Colourimetric method

FOR REFERENCE PURPOSES ONLY



You have either reached a page that is unavailable for viewing or reached your viewing limit for this book.

FOR REFERENCE PURPOSES ONLY



You have either reached a page that is unavailable for viewing or reached your viewing limit for this book.

FOR REFERENCE PURPOSES ONLY



You have either reached a page that is unavailable for viewing or reached your viewing limit for this book.

FOR REFERENCE PURPOSES ONLY



You have either reached a page that is unavailable for viewing or reached your viewing limit for this book.

FOR REFERENCE PURPOSES ONLY



You have either reached a page that is unavailable for viewing or reached your viewing limit for this book.

FOR REFERENCE PURPOSES ONLY



You have either reached a page that is unavailable for viewing or reached your viewing limit for this book.

FOR REFERENCE PURPOSES ONLY



You have either reached a page that is unavailable for viewing or reached your viewing limit for this book.

FOR REFERENCE PURPOSES ONLY



You have either reached a page that is unavailable for viewing or reached your viewing limit for this book.

FOR REFERENCE PURPOSES ONLY



You have either reached a page that is unavailable for viewing or reached your viewing limit for this book.

FOR REFERENCE PURPOSES ONLY



You have either reached a page that is unavailable for viewing or reached your viewing limit for this book.

FOR REFERENCE PURPOSES ONLY



You have either reached a page that is unavailable for viewing or reached your viewing limit for this book.

FOR REFERENCE PURPOSES ONLY



You have either reached a page that is unavailable for viewing or reached your viewing limit for this book.

FOR REFERENCE PURPOSES ONLY



You have either reached a page that is unavailable for viewing or reached your viewing limit for this book.

FOR REFERENCE PURPOSES ONLY



You have either reached a page that is unavailable for viewing or reached your viewing limit for this book.

Olefins are the major contributors to the 'smog forming potential' (SFP) of the exhaust gas. Test reported by Caplan, show that the olefins contribute nearly 86% to the reactivity of the exhaust emission, 84% to the reactivity of the carburettor hot soak evaporative emissions and 74% to the reactivity of tank evaporative emissions.

TABLE 11.2 *Typical Emissions Levels and Control Standards*

Source of emission	Pollutant	Typical emission	Emission as % wt of supplied fuel	Estimated pollution/car/day	US national standards for control equipment 1970
Exhaust gas	HC	860 ppm	6	337 g	180 ppm
	CO	3.1%	—	2150 g	1%
	NO _x	1500 ppm	—	114 g	600–800 ppm or 350 ppm as NO
Crank-case Blowby	} HC	—	2.5	164 g	—
Fuel Tank		HC	—	—	114 g

Table 11.2 shows typical emission levels and control standards

11.5.1 Exhaust Emissions

Hydrocarbons: Exhaust hydrocarbons are composed of a large number of individual hydrocarbons and partially oxidised hydrocarbons produced during the combustion process. Table 11.3, shows the variation in the average emission under different engine loadings.

The effects of various operating variables on exhaust emissions are discussed below.

TABLE 11.3 *Percentage of Total HC Contribution by Driving Modes*

Mode	Driving time		Exhaust volume		HC Concentration ppm (C)	A × B × C	HC contributed %
	Total %	Time ratio (A)	cu m/min	Volume ratio (B)			
Idling	19	1.0	0.224	1.0	800	800	5
Accelerating	19	1.0	1.68	7.5	540	4050	26
Cruising	37	2.0	0.98	4.4	485	4270	27
Decelerating	25	1.3	0.224	1.0	5000	6500	42

11.6 Air-fuel Ratio

A decrease in the AF ratio increases the HC content (expressed as wt % of

FOR REFERENCE PURPOSES ONLY



You have either reached a page that is unavailable for viewing or reached your viewing limit for this book.

FOR REFERENCE PURPOSES ONLY



You have either reached a page that is unavailable for viewing or reached your viewing limit for this book.

FOR REFERENCE PURPOSES ONLY



You have either reached a page that is unavailable for viewing or reached your viewing limit for this book.

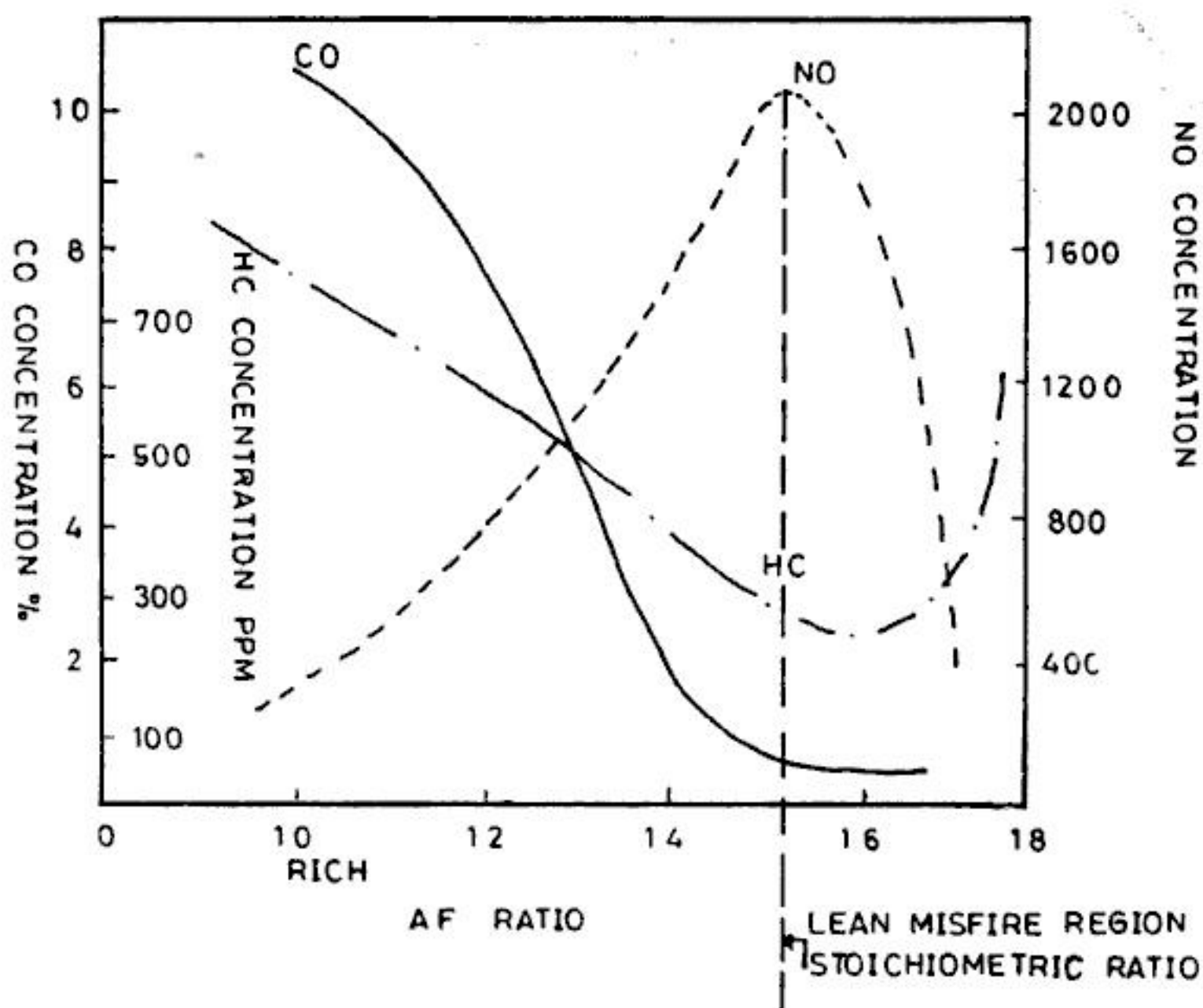

Fig. 11.3 Effect of AF Ratio

- (iii) Use of exhaust heat to pre-heat the mixture at part-loads,
- (iv) Use of automatic transmission (because manual transmission produces a high intake vacuum during deceleration as the engine is motored at high speeds, thus giving high HC emissions and momentary deceleration during manual shifting of gears as well as the subsequent action of acceleration of the pump which increases HC concentration),
- (v) Special devices for reducing or cutting off fuel supply during deceleration.

(e) Low quench combustion chambers

The combustion of petrol-air mixture within any engine is by no means an instantaneous event. The flame is propagated from the ignition point at varying rates depending among other things, on turbulence, the presence of petrol vapour and even the size of the fuel particles suspended in the air. The flame is, in fact, completely quenched as it approaches the chamber walls; thus leaving a thin layer of unburned HC, part of which mixes with and escapes with the products of combustion. Certain areas in the chamber may possibly be predisposed to causing this phenomenon. HC emissions are reported to increase when flame quenching occurs. Flame photography and sampling techniques corroborate the above hypothesis.

The surface-volume ratio is a significant parameter to be considered in designing the chamber, for a low S/V ratio is conducive for low emissions. The wall and mixture temperature, as also the amount of deposits on the walls influence HC emission concentrations.

FOR REFERENCE PURPOSES ONLY



You have either reached a page that is unavailable for viewing or reached your viewing limit for this book.

FOR REFERENCE PURPOSES ONLY



You have either reached a page that is unavailable for viewing or reached your viewing limit for this book.

FOR REFERENCE PURPOSES ONLY



You have either reached a page that is unavailable for viewing or reached your viewing limit for this book.

influence on reactor performance. The fraction between 0.15 and 0.4 ensures good oxidation.

11.11.4 Catalytic Reduction

The laboratory treatment of engine exhaust with a copper-cobalt-alumina catalyst can reduce NO by 80%. Approximately 1.5% CO in the exhaust is necessary to supply the reducing agent. This requires rich setting of the carburettor which lowers fuel economy.

11.11.5 Lean Operation

This approach merely supplies more air as a diluent rather than exhaust gas. Severe drivability problems due to momentary leanness during transient conditions causing misfires may be overcome by supplying a homogeneous mixture under transient conditions.

11.12 Control of Evaporative Emissions

There are two main sources of evaporative emissions viz., the fuel tank and the carburettor. The principal factors governing tank emissions are fuel volatility and ambient temperature but tank design and location can also influence tank temperature and thus tank emissions. Insulation of the fuel tank to reduce temperature, sealed and pressurised fuel systems, and vapour collection systems have all been explored to reduce tank emissions.

Carburettor emissions may be divided into two categories; 'running' losses occurring during engine operation and 'hot soak' losses occurring when the vehicle is parked. On account of internal venting of carburettors the running losses are insignificant. Carburettor losses are substantial only during hot soak following a period of vehicle operation. The fuel volatility and carburettor design also greatly affect the carburettor emissions.

11.13 Control of Crank-Case Emissions

These consist of engine blowby gases, ventilation air and crank-case lubricant fumes. For air pollution blowby is most important and the principal constituents in blowby gases are hydrocarbons. The quantity of blowby depends on many engine design and operating variables and it may be enhanced by poor engine maintenance and by use of crankcase oils.

Designers are shifting crank-case exhaust vents from simple open ending to a feed back. New engines equipped with this Positive Crank-case Ventilation (PCV) system return crank-case vapours through a vacuum valve, back to downstream side of the carburettor. Recycling burns hydrocarbons in the cylinders, dropping overall pollution by 25% (Fig. 11.6).

FOR REFERENCE PURPOSES ONLY



You have either reached a page that is unavailable for viewing or reached your viewing limit for this book.

FOR REFERENCE PURPOSES ONLY



You have either reached a page that is unavailable for viewing or reached your viewing limit for this book.

FOR REFERENCE PURPOSES ONLY



You have either reached a page that is unavailable for viewing or reached your viewing limit for this book.

carbon monoxide emissions by about 25% in the first instance. Further reductions would need major engine modifications which may be kept in view for future models.

11.16 Conclusion

Extensive research conducted during the last 15 years has given valuable insight into and complete understanding of the causes and control of automotive engine emissions. The cost, complexity and maintenance of emission-controlled piston engines in passenger cars are all increasing. Future strategy should be to go in for unleaded gasoline even at the expense of a 2–4% increase in cost that it may entail.

The various alternatives for automotive application discussed above are no doubt plausible but problematical today. While efforts should be made to make them more amenable to vehicular use, the gasoline powered SI engine with emission-control devices seems to be the best compromise in the national interest.

We must go the wholehog to forestall the devastating effects of air pollution due to automotive vehicles by incorporating methods to control emissions. A uniform regulation is also necessary for automobile pollution control in our country.

The automobile industry in India must increase the scope and efficiency of its research. It is inevitable that as traffic density increases, legislation concerning safety, noise, and exhaust emissions will become imperative and mandatory.

QUESTIONS

1. How are the emissions from gasoline-powered vehicles classified?
2. What is the effect of engine operating conditions on the composition of auto exhaust?
3. Write short notes in 15 sentences on
 - (a) Exhaust emissions
 - (b) Crank-case emissions
 - (c) Evaporative emissions
4. What are the various approaches to minimize exhaust emissions?
5. Suggest suitable methods of minimizing crank-case emissions and evaporative emissions.
6. Discuss the recent developments in the automobile industry to reduce air pollution.
7. Write brief notes on:
 - (a) Air-fuel ratio
 - (b) Compression ratio.

FOR REFERENCE PURPOSES ONLY



You have either reached a page that is unavailable for viewing or reached your viewing limit for this book.

FOR REFERENCE PURPOSES ONLY



You have either reached a page that is unavailable for viewing or reached your viewing limit for this book.

FOR REFERENCE PURPOSES ONLY



You have either reached a page that is unavailable for viewing or reached your viewing limit for this book.

2. *Vegetation Damage*

The effects observed are silvering and bronzing of the underside of leaves, followed by collapse of cells, and necrosis. Growth retardation has also been reported. The three principal phytotoxicants are ozone, nitrogen dioxide, and PAN. This has resulted in economic loss. The details are given in Chapter 7.

3. *Visibility Reduction*

This is perhaps the most commonly observed effect of photochemical smog. The aerosol particles causing the photochemical smog contain compounds of carbon, oxygen, hydrogen, nitrogen, sulphur, and halides. The size of the particles is about 0.3μ . The liquid phase is largely made up of organic matter. Attempts are now being made to establish a quantitative relationship between visibility and oxidant index.

4. *Cracking of Rubber*

This is primarily due to the ozone constituent of photochemical smog. An important economic effect of smog in Los Angeles, is the deterioration of the side walls of automobile tyres. To overcome this problem, an anti-ozonant is being used. The other rubber products that are affected are gaskets, hoses, and wire insulation. This has been discussed in Sec. 8.4.

5. *Fading of Dyes*

This is another important economic effect of photochemical smog, which has been discussed in Sec. 8.4.

QUESTIONS

1. Explain the theory of formation of photochemical smog.
2. What are the factors affecting photochemical reactions?
3. Explain the term 'oxidants'. How are they measured?
4. Explain the effects of photochemical smog on human beings, plants, and materials.
5. Write short notes on:
 - (a) Photochemical smog
 - (b) Oxidants
6. "Photochemical air pollution occurs predominantly in highly motorised areas and where inversion conditions prevail in the atmosphere." Substantiate the statement with special reference to Los Angeles.

FOR REFERENCE PURPOSES ONLY



You have either reached a page that is unavailable for viewing or reached your viewing limit for this book.

FOR REFERENCE PURPOSES ONLY



You have either reached a page that is unavailable for viewing or reached your viewing limit for this book.

FOR REFERENCE PURPOSES ONLY



You have either reached a page that is unavailable for viewing or reached your viewing limit for this book.

solids move along the chamber with the velocity of the gas and also settle with Stoke's velocity. A particle entering the chamber at the top will be collected by the chamber, if its settling time is the same (or less than) the time the gas takes to pass through the chamber.

$$\begin{aligned} \text{Thus,} \quad & \frac{h}{V_s} = \frac{L}{V} \\ \text{or} \quad & V_s = \frac{hV}{L} \end{aligned} \quad (13.1)$$

where,

L = length of the chamber

V = horizontal velocity of the carrier gas

V_s = settling velocity of particulates

h = height through which the particulates travel before settling down.

By Stoke's Law

$$V_s = \frac{g(\rho_p - \rho)D^2}{18\mu} \quad (13.2)$$

where,

D = Diameter of the particle

g = acceleration due to gravity

ρ_p = density of the particle

ρ = density of the gas

μ = viscosity of the gas.

From equation (13.1) and (13.2), we get

$$D = \left[\frac{18Vh\mu}{Lg(\rho_p - \rho)} \right]^{1/2} \quad (13.3)$$

From Eq. (13.3), we can calculate the minimum size of the particle that can be removed in a settling chamber.

From Eq. (13.3) it is also seen that efficiency is improved if the height to be travelled by the particles is less. To achieve this, horizontal trays or shelves are sometimes incorporated in the chambers. The trays (plates) are fitted at about 1-3 cms height intervals. The increase in efficiency obtained by the insertion of horizontal trays is directly proportional to the number of trays. Even with such equipment, however, the minimum particle size which can be removed in practice is about 10μ . Also, the use of this modified settling chamber is limited by difficulties in cleaning the closely spaced trays and by their tendency to warp during high temperature operation.

13.6.1 Advantages

1. Low initial cost
2. Simple construction
3. Low maintenance cost
4. Low pressure drop
5. Dry and continuous disposal of solid particulates

FOR REFERENCE PURPOSES ONLY



You have either reached a page that is unavailable for viewing or reached your viewing limit for this book.

FOR REFERENCE PURPOSES ONLY



You have either reached a page that is unavailable for viewing or reached your viewing limit for this book.

FOR REFERENCE PURPOSES ONLY



You have either reached a page that is unavailable for viewing or reached your viewing limit for this book.

particles thus impinged rebound back into the moving gas stream in the inlet chamber and are removed from the collector by a secondary air circuit (Fig. 13.3).

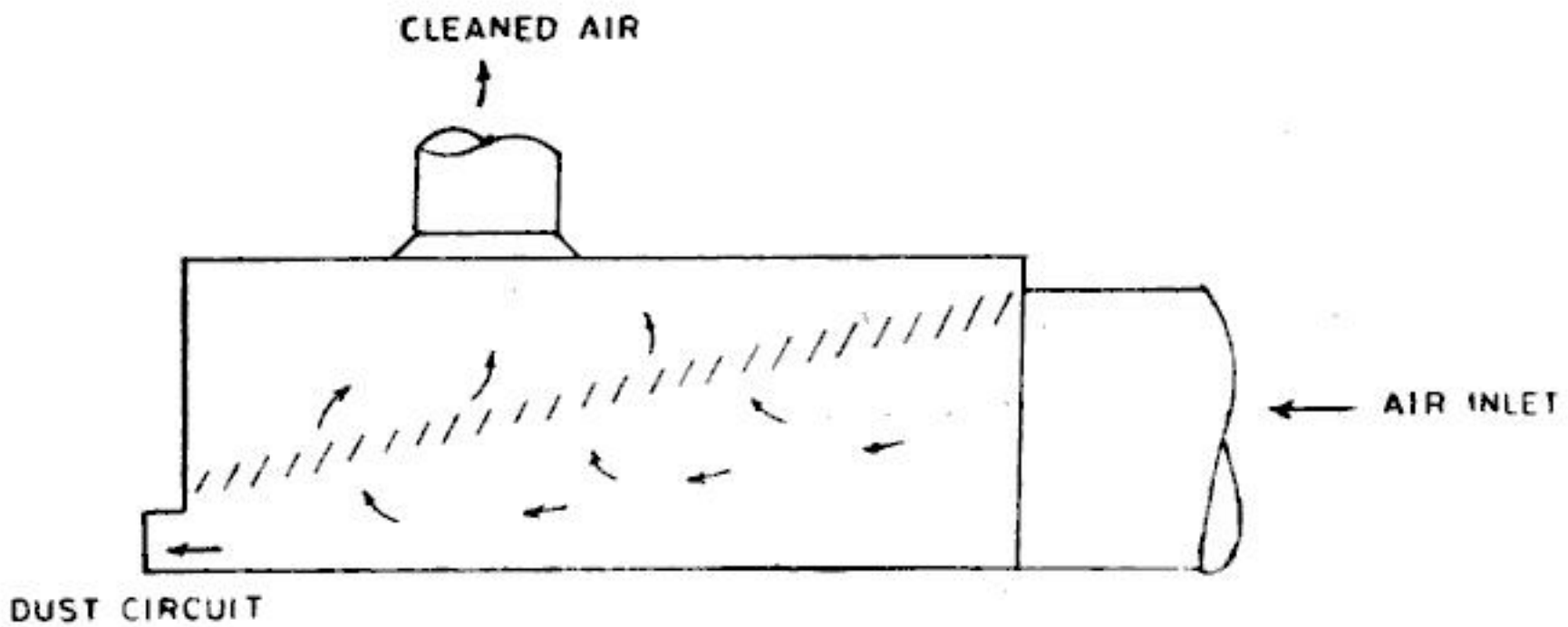

Fig. 13.3 Louvre dust collector

Efficiency of this type depends upon louvre spacing, closer spacing producing higher efficiency. The operating velocities normally are of the order of 12–15 m/s at the inlet. The device is suitable for removing particles larger than $30\ \mu$ in diameter.

The advantages of a louvre dust collector are, simple and low cost of construction, as well as, moderate low pressure drop for the degree of removal obtained. The disadvantages are, clogging of the louvre grid with a corresponding reduction in efficiency and excessive abrasion of louvre elements.

Dust Trap

The dust trap is another common type of inertial separator. In this device, the dust laden gas is introduced into a central pipe (cylindrical or tapered as shown in Fig. 13.4 by dotted line), and is made to undergo a change in direction by 180° . Dust, because of inertia, settles in the conical chamber.

This device is useful when the dust loading is high ($> 100\ \text{g/m}^3$) and quantity of gas to be handled is low. Normally gas velocity in the inlet is about 10 m/s and in the chamber it is reduced to about 1 m/s. The collection efficiency for particles greater than $30\ \mu$ is about 70%.

It is not necessary that the gas must reverse its flow. Sometimes, deflection of gas to a lesser degree is sufficient. A dust trap, is sometimes used as a pre-cleaner, to reduce the load of the larger diameter particles so as to pass through more efficient mechanisms, for removing smaller particulates.

13.8 Cyclones

This class of separators is the most common of a general group of separators

FOR REFERENCE PURPOSES ONLY



You have either reached a page that is unavailable for viewing or reached your viewing limit for this book.

FOR REFERENCE PURPOSES ONLY



You have either reached a page that is unavailable for viewing or reached your viewing limit for this book.

FOR REFERENCE PURPOSES ONLY



You have either reached a page that is unavailable for viewing or reached your viewing limit for this book.

the exit gas stream at a point below the zone of maximum turbulence. This is done by adding a central tube called a vortex finder which projects into the cyclone body below the turbulent entry region to confine the rising inner gas spiral.

In general, increase in collection efficiency will result if there is an increase in any of the following: dust particle size, dust particle density, gas inlet velocity, inlet dust loading, cyclone body length (number of gas revolutions), and ratio of body diameter to gas outlet tube diameter.

On the contrary, collector efficiency will decrease if there is an increase in gas viscosity or density, cyclone diameter, gas outlet diameter, inlet width and inlet area.

To get increased efficiency, especially for the collection of smaller sized particles, a small diameter, long taper cyclone should be used.

Table 13.1 indicates the efficiency range of cyclones.

TABLE 13.1 *Efficiency Range of Cyclones*

Particle size range (μ)	Efficiency percentage	
	Conventional	High efficiency
Less than 5	Less than 50	50-80
5-20	50-80	80-95
15-40	80-95	95-99
Greater than 40	95-99	95-99

13.8.2 Tangential Inlet and Involute Inlet—A Comparison

Inlets are of two types—tangential and involute. A straight tangential entry creates quite a bit of turbulence which will lead to back mixing and loss of efficiency even when a vortex finder is included in the cyclone design. On the other hand, the involute design (Fig. 13.6) brings in the gas parallel to the outer edge of the cyclone (tangent at that point) and leads it around a spiral for 180° to enter the top section with minimum turbulence. The other advantages of the involute design are better particle projection to the wall and a decrease in the loss of finer particles. The higher velocity in the central core can cause a slight increase in the Bernoulli effect, drawing more fine particles from the wall towards the central core. However, fines losses at the top and the pressure loss are much less and the efficiency much higher for the involute design than for the tangential entry design.

13.8.3 Operating Problems

There are three important operating problems associated with cyclones. They are erosion, corrosion and material build-up.

Erosion Heavy, hard, sharp-edged particles, in a high concentration, moving at high velocity in the cyclone, continuously scrape against the wall and can erode the metallic surface unless suitable materials are used.

FOR REFERENCE PURPOSES ONLY



You have either reached a page that is unavailable for viewing or reached your viewing limit for this book.

FOR REFERENCE PURPOSES ONLY



You have either reached a page that is unavailable for viewing or reached your viewing limit for this book.

FOR REFERENCE PURPOSES ONLY



You have either reached a page that is unavailable for viewing or reached your viewing limit for this book.

In general, if the particle-size distribution is such that most of the particulates can be removed in cyclones, then in such a case, very high overall efficiencies can be obtained by operating cyclones in series.

13.9 Filters

Filtration is one of the most reliable, efficient and economic methods by which particulate matter can be removed from gases. Filters can be broadly divided into the following two types.

1. Fabric or cloth filters
2. Fibrous or deep-bed filters

In cloth filters, the filter is in the form of a fabric bag arrangement—tubular bags or as cloth envelopes, and is suitable for a dust loading of the order of 1 g/cu m. In case of deep-bed filters, a fibrous medium like mats of wool, cellulose, etc., acts as a separator and the collection takes place in the interstices of the bed, and is suitable for light dust loads of the order of 1 mg/cu m.

13.9.1 Fabric or Cloth Filters

The most common type of fabric collector is the tubular type, consisting of tubular bags. A bag house or bag filter consists of numerous vertical bags 120–400 mm diameter and 2–10 m long. They are suspended with open ends attached to a manifold. The hopper at the bottom serves as a collector for the dust (Fig. 13.8).

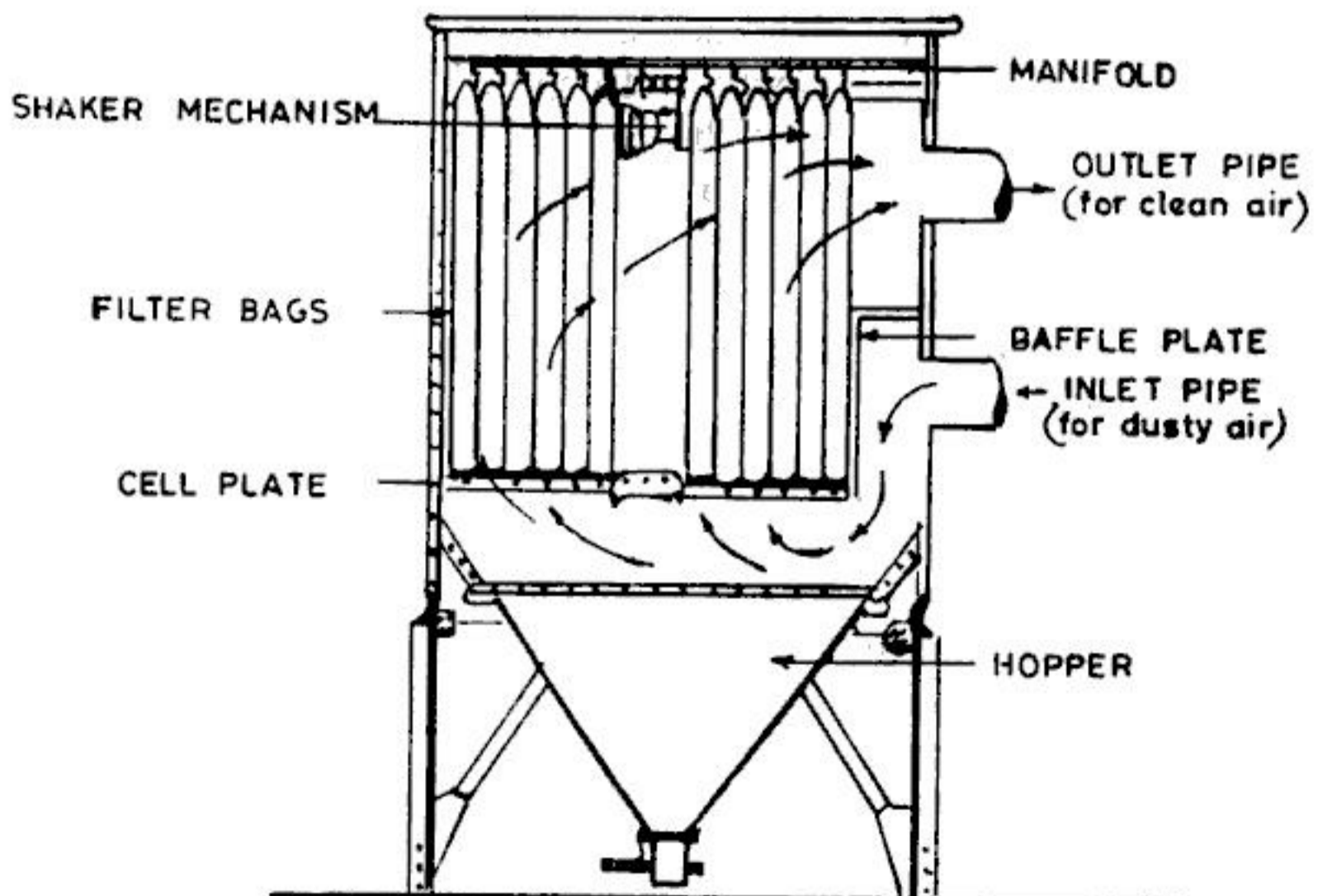

Fig. 13.8 Bag house filter

FOR REFERENCE PURPOSES ONLY



You have either reached a page that is unavailable for viewing or reached your viewing limit for this book.

FOR REFERENCE PURPOSES ONLY



You have either reached a page that is unavailable for viewing or reached your viewing limit for this book.

FOR REFERENCE PURPOSES ONLY



You have either reached a page that is unavailable for viewing or reached your viewing limit for this book.

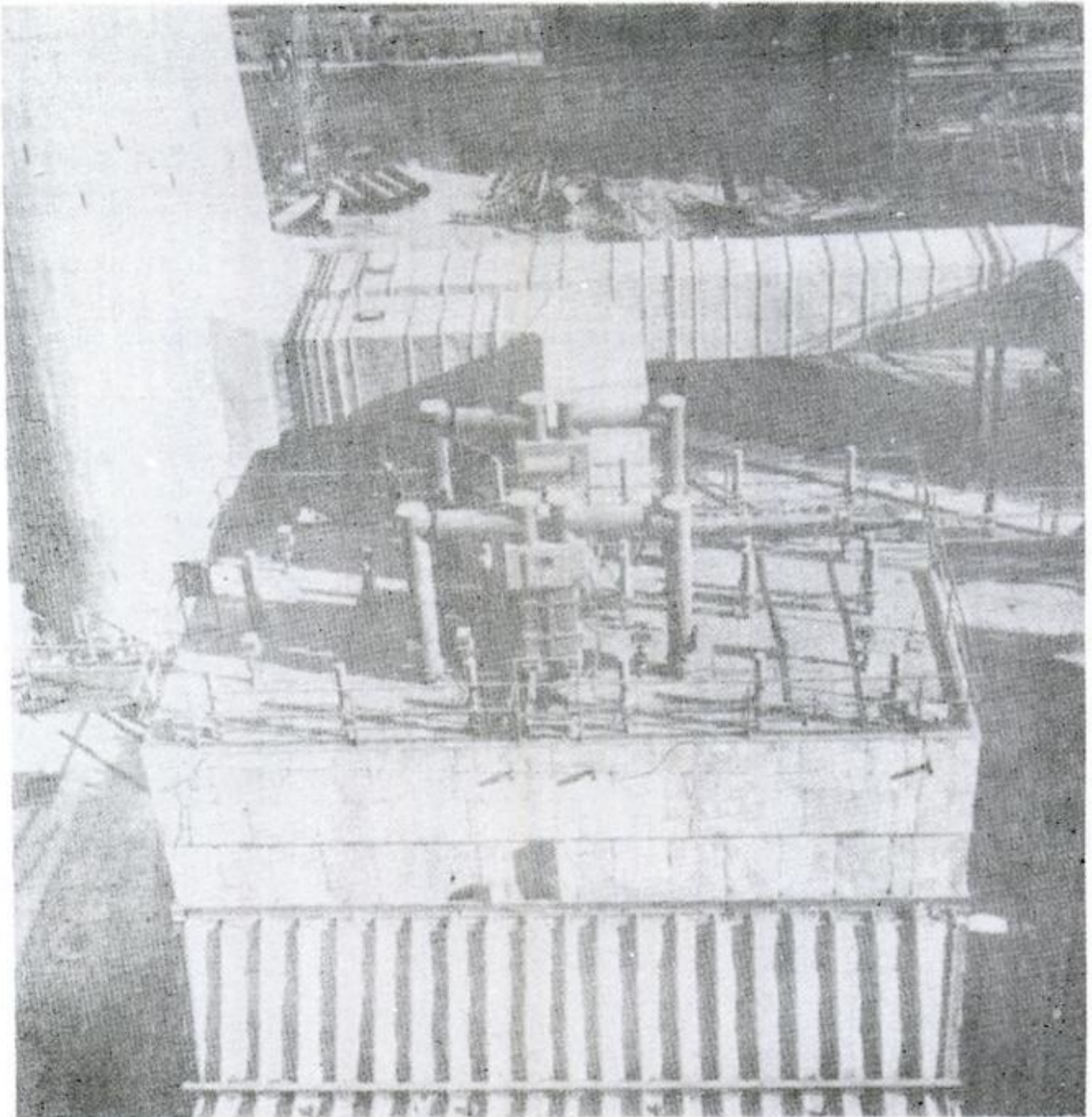

***Top view of an ESP showing outlet ducting to the stack, TR sets and IIT bus duct and rappers.
(Courtesy: VOLTAS LTD.)***

FOR REFERENCE PURPOSES ONLY



You have either reached a page that is unavailable for viewing or reached your viewing limit for this book.

FOR REFERENCE PURPOSES ONLY



You have either reached a page that is unavailable for viewing or reached your viewing limit for this book.

FOR REFERENCE PURPOSES ONLY



You have either reached a page that is unavailable for viewing or reached your viewing limit for this book.

FOR REFERENCE PURPOSES ONLY



You have either reached a page that is unavailable for viewing or reached your viewing limit for this book.

FOR REFERENCE PURPOSES ONLY



You have either reached a page that is unavailable for viewing or reached your viewing limit for this book.

FOR REFERENCE PURPOSES ONLY



You have either reached a page that is unavailable for viewing or reached your viewing limit for this book.

FOR REFERENCE PURPOSES ONLY



You have either reached a page that is unavailable for viewing or reached your viewing limit for this book.

FOR REFERENCE PURPOSES ONLY



You have either reached a page that is unavailable for viewing or reached your viewing limit for this book.

FOR REFERENCE PURPOSES ONLY



You have either reached a page that is unavailable for viewing or reached your viewing limit for this book.

FOR REFERENCE PURPOSES ONLY



You have either reached a page that is unavailable for viewing or reached your viewing limit for this book.

FOR REFERENCE PURPOSES ONLY



You have either reached a page that is unavailable for viewing or reached your viewing limit for this book.

FOR REFERENCE PURPOSES ONLY



You have either reached a page that is unavailable for viewing or reached your viewing limit for this book.

FOR REFERENCE PURPOSES ONLY



You have either reached a page that is unavailable for viewing or reached your viewing limit for this book.

FOR REFERENCE PURPOSES ONLY



You have either reached a page that is unavailable for viewing or reached your viewing limit for this book.

FOR REFERENCE PURPOSES ONLY



You have either reached a page that is unavailable for viewing or reached your viewing limit for this book.

FOR REFERENCE PURPOSES ONLY



You have either reached a page that is unavailable for viewing or reached your viewing limit for this book.

FOR REFERENCE PURPOSES ONLY



You have either reached a page that is unavailable for viewing or reached your viewing limit for this book.

192 Air Pollution

1. **Cyclones:** Cyclones are generally cheap to install. The power consumption is moderate. The maintenance cost is also normally not very high. However, it must be noted that special conditions such as corrosive gas or abrasive dust considerably influence the life and thereby affect maintenance cost.

2. **Filters:** A bag filter is comparatively expensive to install. Its power consumption is moderate. In most cases, the maintenance cost is high because the bags have to be repaired or replaced regularly. The nature of the gas and the dust decide the frequency of such maintenance work.

3. **Electrostatic precipitators:** They are generally the most expensive dust collectors as regards installation cost. However, they can be expected to have the longest life. Further, the power consumption is moderate to low as the pressure drop is very low and the required high voltage power is moderate. An ESP is not exposed to much mechanical wear if measures are taken to avoid condensation and corrosion. Therefore, the maintenance cost is moderate.

4. **Scrubbers:** The installation cost for a wet collector is moderate. Also, the maintenance cost is generally not very high. But the comparatively high pressure drop, especially in a high efficiency scrubber, can involve rather high power consumption.

QUESTIONS

1. What are the main principles of air pollution abatement?
2. What are the objectives of using control equipment?
3. List the various types of collection equipment for particulates.
4. How do you calculate the efficiency of a separating device?
5. What are the advantages of using collectors in series?
6. Explain with a neat sketch, the principle, construction, and working of a settling chamber. How can its efficiency be improved?
7. What are the advantages and disadvantages of settling chambers? Give their applications.
8. What is the principle of inertial separators? Mention the types of inertial separators.
9. Explain with neat sketches
 - (a) Baffle type separator
 - (b) Louvre type separator
 - (c) Dust traps
10. Mention the advantages and disadvantages of the following inertial separators:
 - (a) Baffle type separator
 - (b) Louvre type separator
11. With a neat sketch explain the principle, construction, and working of a cyclone separator.
12. Draw a neat sketch of a typical cyclone separator and label the parts. Also, give the proportions of the various parts with respect to cyclone diameter.
13. Enumerate the factors on which the collection efficiency of a cyclone depends.
14. Distinguish between 'conventional' and 'high efficiency' cyclones.
15. Compare tangential inlet and involute inlet for cyclones.

FOR REFERENCE PURPOSES ONLY



You have either reached a page that is unavailable for viewing or reached your viewing limit for this book.

FOR REFERENCE PURPOSES ONLY



You have either reached a page that is unavailable for viewing or reached your viewing limit for this book.

FOR REFERENCE PURPOSES ONLY



You have either reached a page that is unavailable for viewing or reached your viewing limit for this book.

FOR REFERENCE PURPOSES ONLY



You have either reached a page that is unavailable for viewing or reached your viewing limit for this book.

As per IS: 9078 (1979), the miniature smoke chart shall have the same precision as the Ringelmann Chart. The miniature chart is not intended for use as a substitute for the Ringelmann Chart but the results obtained are expected to be similar to those from the Ringelmann Chart. A miniature smoke chart may be used for readings of a preliminary nature.

The gray shades marked on the chart correspond to similar shades of the Ringelmann Chart. The chart is held at arm's length or preferably at a distance of 1.5 m from the observer's eye, with the help of a holder while recording observations. For details IS: 9078 can be referred.

14.4 Other Methods of Measurement of Smoke

Nowadays many other devices like photoelectric and photographic devices are also being used for the measurement of smoke density. Even optical methods are being employed. A good example of an instrument used for estimating smoke density based on the principle of optics is the 'smoke-scope'.

A smoke-scope is an instrument developed by the Mine Safety Appliance Company, USA. It is an optical instrument used for estimating the density of the smoke coming from a stack. It has several features which help in maintaining accuracy and reproducibility of observations even though the stack is viewed from different angles or under different conditions of lighting and background.

While making observations, the stack is viewed through one barrel of the instrument, and the smoke is observed through an aperture in the centre of the screen. Light from the area adjacent to the stack comes through a second barrel and illuminates a standard density film which is used for comparison with the smoke. Consequently, an image of the reference film appears on the screen surrounding the aperture. This helps in easy comparison with the smoke. Refocussing of the eye is not required while making observations because, with the help of a lens, the image of the reference is made to appear to be at a distance equivalent to that of the stack. Also, as illuminations of the smoke and the reference are simultaneously influenced by the same factors, automatic compensation takes place under different conditions.

14.5 Smoke and Public Health

Smoke may affect public health through:

1. Irritation of the eye membranes
2. Irritation of the respiratory tract
3. Infection of the ear

FOR REFERENCE PURPOSES ONLY



You have either reached a page that is unavailable for viewing or reached your viewing limit for this book.

FOR REFERENCE PURPOSES ONLY



You have either reached a page that is unavailable for viewing or reached your viewing limit for this book.

FOR REFERENCE PURPOSES ONLY



You have either reached a page that is unavailable for viewing or reached your viewing limit for this book.

FOR REFERENCE PURPOSES ONLY



You have either reached a page that is unavailable for viewing or reached your viewing limit for this book.

FOR REFERENCE PURPOSES ONLY



You have either reached a page that is unavailable for viewing or reached your viewing limit for this book.

FOR REFERENCE PURPOSES ONLY



You have either reached a page that is unavailable for viewing or reached your viewing limit for this book.

FOR REFERENCE PURPOSES ONLY



You have either reached a page that is unavailable for viewing or reached your viewing limit for this book.

2. Substances of similar or dissimilar chemical constitution may have similar odours
3. Nature and strength of the odour may change on dilution
4. Weak odours are not perceived in the presence of strong odours
5. Odours of the same strength blend to produce a combination in which one or both may be unrecognizable
6. Constant intensity of odours causes an individual to quickly lose awareness of the sensation and only notice it when it varies in intensity
7. Fatigue for one odour may not affect the perception of dissimilar odours but will interfere with the perception of similar odours
8. An unfamiliar odour is more likely to cause complaint than a familiar one
9. Two or more odorous substances may cancel the smell of each other
10. Odours travel downwind
11. Man can smell at a distance
12. Many animals have a keener sense of olfaction than man
13. Likes and dislikes often depends on the association of the scent with pleasant or unpleasant experiences
14. The number of different and distinct smells is great

16.3 Source of Odours

An odorant generally originates from a solid, a liquid, or a concentrated gas. Odour sources may be confined in space, like emission from ducts, or they may be unconfined, like drainage ditches, and settling lagoons.

Hydrogen sulphide, carbon disulphide, mercaptans, products of decomposition of proteins (especially those of animal origin), phenols, and some petroleum hydrocarbons are the malodours which are very common.

Odoriferous compounds are also generated due to various human activities. Garbage dumps, sewage works, and agricultural activities are typical examples. Bad smell is also produced by decaying vegetation. The exhaust from motor vehicles is also a common source of malodour.

The sources of odour are so many, that it is almost impossible to prepare a complete list of them.

Table 16.1 indicates the various odorous industrial operations.

16.4 Measurement of Odour

The measurement of odour falls into two categories:

1. Determination of the threshold concentration (minimum identification level) of odoriferous gases
2. Determination of the type and intensity of atmospheric odours

FOR REFERENCE PURPOSES ONLY



You have either reached a page that is unavailable for viewing or reached your viewing limit for this book.

FOR REFERENCE PURPOSES ONLY



You have either reached a page that is unavailable for viewing or reached your viewing limit for this book.

FOR REFERENCE PURPOSES ONLY



You have either reached a page that is unavailable for viewing or reached your viewing limit for this book.

FOR REFERENCE PURPOSES ONLY



You have either reached a page that is unavailable for viewing or reached your viewing limit for this book.

FOR REFERENCE PURPOSES ONLY



You have either reached a page that is unavailable for viewing or reached your viewing limit for this book.

FOR REFERENCE PURPOSES ONLY



You have either reached a page that is unavailable for viewing or reached your viewing limit for this book.

FOR REFERENCE PURPOSES ONLY



You have either reached a page that is unavailable for viewing or reached your viewing limit for this book.

FOR REFERENCE PURPOSES ONLY



You have either reached a page that is unavailable for viewing or reached your viewing limit for this book.

FOR REFERENCE PURPOSES ONLY



You have either reached a page that is unavailable for viewing or reached your viewing limit for this book.

FOR REFERENCE PURPOSES ONLY



You have either reached a page that is unavailable for viewing or reached your viewing limit for this book.

FOR REFERENCE PURPOSES ONLY



You have either reached a page that is unavailable for viewing or reached your viewing limit for this book.

FOR REFERENCE PURPOSES ONLY



You have either reached a page that is unavailable for viewing or reached your viewing limit for this book.

FOR REFERENCE PURPOSES ONLY



You have either reached a page that is unavailable for viewing or reached your viewing limit for this book.

FOR REFERENCE PURPOSES ONLY



You have either reached a page that is unavailable for viewing or reached your viewing limit for this book.

FOR REFERENCE PURPOSES ONLY



You have either reached a page that is unavailable for viewing or reached your viewing limit for this book.

FOR REFERENCE PURPOSES ONLY



You have either reached a page that is unavailable for viewing or reached your viewing limit for this book.

FOR REFERENCE PURPOSES ONLY



You have either reached a page that is unavailable for viewing or reached your viewing limit for this book.

FOR REFERENCE PURPOSES ONLY



You have either reached a page that is unavailable for viewing or reached your viewing limit for this book.

FOR REFERENCE PURPOSES ONLY



You have either reached a page that is unavailable for viewing or reached your viewing limit for this book.

FOR REFERENCE PURPOSES ONLY



You have either reached a page that is unavailable for viewing or reached your viewing limit for this book.

FOR REFERENCE PURPOSES ONLY



You have either reached a page that is unavailable for viewing or reached your viewing limit for this book.

FOR REFERENCE PURPOSES ONLY



You have either reached a page that is unavailable for viewing or reached your viewing limit for this book.

FOR REFERENCE PURPOSES ONLY



You have either reached a page that is unavailable for viewing or reached your viewing limit for this book.

FOR REFERENCE PURPOSES ONLY



You have either reached a page that is unavailable for viewing or reached your viewing limit for this book.

FOR REFERENCE PURPOSES ONLY



You have either reached a page that is unavailable for viewing or reached your viewing limit for this book.

FOR REFERENCE PURPOSES ONLY



You have either reached a page that is unavailable for viewing or reached your viewing limit for this book.

FOR REFERENCE PURPOSES ONLY



You have either reached a page that is unavailable for viewing or reached your viewing limit for this book.

FOR REFERENCE PURPOSES ONLY



You have either reached a page that is unavailable for viewing or reached your viewing limit for this book.

Emissions and Controls

Dust, fume and SO_2 are evolved from zinc concentrate roasting or sintering. Particulates are caught in conventional bag houses or electrostatic precipitators. Sulphur dioxide in the more concentrated gas streams is utilised for direct production of sulphuric acid by the contact process, while more dilute gas streams are scrubbed with aqueous ammonia solution. Leaching and electrolysis do not emit significant amounts of particulates or gases. Tanks in which leaching and electrolyte purifications are done are covered and ventilated to prevent worker exposure to possible toxic gases or mists. Stack sampling surveys and continuous ambient monitoring have shown that the outplant emissions from zinc leaching and electrolysis operation are insignificant.

Impact of Regulations on Emission Control Practices

In recent years the United States zinc smelting industry has undergone tremendous change due to imposition of environmental control measures, sharply rising costs and the lack of an attractive domestic climate for the investment of capital in production facilities.

19.6.4 Aluminium*Mining and Ore Treatment*

Bauxite is the base ore for aluminium production. Most bauxite ore is purified by the Bayer process.

Electrolysis

Commercial recovery of aluminium from the oxide is accomplished by a unique electrolytic process discovered simultaneously in 1886 by Hall in United States and Heroult in France.

Emissions and Controls

Calcination of aluminium hydroxides for the production of alumina entails mechanical dust dispersion. The valuable dust is recovered from kiln effluents by a combination of cyclone collectors and electrostatic precipitators. The type and character of emissions depend on the type of electrolytic cell used to electrolyse the alumina feed material. The major pollutants for all types are, gaseous and particulate fluorides. Minor gaseous emissions are CO_2 , CO , N_2O_2 , H_2S , carbon disulphide, sulphur hexafluoride and gaseous fluorocarbons.

Non-fluoride dust emissions are principally mechanically generated carbon dust from the electrodes and mechanically dispersed alumina dust from the charge materials.

The anode plant for a pre-baked electrode operation can be the source of significant SO_2 and hydrocarbon emissions particularly tarry and distillate

FOR REFERENCE PURPOSES ONLY



You have either reached a page that is unavailable for viewing or reached your viewing limit for this book.

FOR REFERENCE PURPOSES ONLY



You have either reached a page that is unavailable for viewing or reached your viewing limit for this book.

FOR REFERENCE PURPOSES ONLY



You have either reached a page that is unavailable for viewing or reached your viewing limit for this book.

FOR REFERENCE PURPOSES ONLY



You have either reached a page that is unavailable for viewing or reached your viewing limit for this book.

FOR REFERENCE PURPOSES ONLY



You have either reached a page that is unavailable for viewing or reached your viewing limit for this book.

FOR REFERENCE PURPOSES ONLY



You have either reached a page that is unavailable for viewing or reached your viewing limit for this book.

FOR REFERENCE PURPOSES ONLY



You have either reached a page that is unavailable for viewing or reached your viewing limit for this book.

FOR REFERENCE PURPOSES ONLY



You have either reached a page that is unavailable for viewing or reached your viewing limit for this book.

FOR REFERENCE PURPOSES ONLY



You have either reached a page that is unavailable for viewing or reached your viewing limit for this book.

260 Air Pollution

Table 19.4 *Standards for Sulphur Dioxide*

Country	$\mu\text{g}/\text{m}^3$	Averaging Time
Belgium	150	24 hours
Bulgaria	50	"
Canada		
Alberta	150	"
Newfoundland	290	"
Ontario	290	"
Czechoslovakia	150	"
East Germany	150	"
Finland	250	"
France		
Paris	75	"
Italy	380	"
Netherlands	125	"
Poland	75	"
Rumania	250	"
Sweden	250	"
Switzerland	75	"
Turkey	150	"
USA		
Colorado	260	"
Delaware—rural	50	"
Delaware—residential	80	"
Delaware—commercial	100	"
Delaware—industrial	160	"
Missouri	120	"
USSR	150	"
Canada		
Alberta	30	1 Year
Manitoba	60	"
Ontario—Industrial—commercial	130	"
Ontario—Residential—rural	50	"
Spain	150	"

Table 19.5 *Standards for Dust Fall*

Country	Dust fall rate $\text{MT}/\text{km}^2/\text{Month}$
Canada	
Ontario—residential—rural	8
Ontario—industrial—commercial	15
Federal Republic of Germany—industrial	13
Poland	3
Canada	
Alberta—residential	6
Alberta—industrial—commercial	17
USA	
Missouri—non-residential	4
Missouri—heavy industrial	10
Montana—residential	6
Montana—heavy industrial	12
Oregon—residential—commercial	6
Oregon—industrial	12

FOR REFERENCE PURPOSES ONLY



You have either reached a page that is unavailable for viewing or reached your viewing limit for this book.

FOR REFERENCE PURPOSES ONLY



You have either reached a page that is unavailable for viewing or reached your viewing limit for this book.

FOR REFERENCE PURPOSES ONLY



You have either reached a page that is unavailable for viewing or reached your viewing limit for this book.

FOR REFERENCE PURPOSES ONLY



You have either reached a page that is unavailable for viewing or reached your viewing limit for this book.

FOR REFERENCE PURPOSES ONLY



You have either reached a page that is unavailable for viewing or reached your viewing limit for this book.

FOR REFERENCE PURPOSES ONLY



You have either reached a page that is unavailable for viewing or reached your viewing limit for this book.

FOR REFERENCE PURPOSES ONLY



You have either reached a page that is unavailable for viewing or reached your viewing limit for this book.

FOR REFERENCE PURPOSES ONLY



You have either reached a page that is unavailable for viewing or reached your viewing limit for this book.

FOR REFERENCE PURPOSES ONLY



You have either reached a page that is unavailable for viewing or reached your viewing limit for this book.

FOR REFERENCE PURPOSES ONLY



You have either reached a page that is unavailable for viewing or reached your viewing limit for this book.

FOR REFERENCE PURPOSES ONLY



You have either reached a page that is unavailable for viewing or reached your viewing limit for this book.

FOR REFERENCE PURPOSES ONLY



You have either reached a page that is unavailable for viewing or reached your viewing limit for this book.

FOR REFERENCE PURPOSES ONLY



You have either reached a page that is unavailable for viewing or reached your viewing limit for this book.

FOR REFERENCE PURPOSES ONLY



You have either reached a page that is unavailable for viewing or reached your viewing limit for this book.

FOR REFERENCE PURPOSES ONLY



You have either reached a page that is unavailable for viewing or reached your viewing limit for this book.

FOR REFERENCE PURPOSES ONLY



You have either reached a page that is unavailable for viewing or reached your viewing limit for this book.

FOR REFERENCE PURPOSES ONLY



You have either reached a page that is unavailable for viewing or reached your viewing limit for this book.

FOR REFERENCE PURPOSES ONLY



You have either reached a page that is unavailable for viewing or reached your viewing limit for this book.

FOR REFERENCE PURPOSES ONLY



You have either reached a page that is unavailable for viewing or reached your viewing limit for this book.

FOR REFERENCE PURPOSES ONLY



You have either reached a page that is unavailable for viewing or reached your viewing limit for this book.

FOR REFERENCE PURPOSES ONLY



You have either reached a page that is unavailable for viewing or reached your viewing limit for this book.

FOR REFERENCE PURPOSES ONLY



You have either reached a page that is unavailable for viewing or reached your viewing limit for this book.

FOR REFERENCE PURPOSES ONLY



You have either reached a page that is unavailable for viewing or reached your viewing limit for this book.

FOR REFERENCE PURPOSES ONLY



You have either reached a page that is unavailable for viewing or reached your viewing limit for this book.

FOR REFERENCE PURPOSES ONLY



You have either reached a page that is unavailable for viewing or reached your viewing limit for this book.

FOR REFERENCE PURPOSES ONLY



You have either reached a page that is unavailable for viewing or reached your viewing limit for this book.

FOR REFERENCE PURPOSES ONLY



You have either reached a page that is unavailable for viewing or reached your viewing limit for this book.

FOR REFERENCE PURPOSES ONLY



You have either reached a page that is unavailable for viewing or reached your viewing limit for this book.

FOR REFERENCE PURPOSES ONLY



You have either reached a page that is unavailable for viewing or reached your viewing limit for this book.

FOR REFERENCE PURPOSES ONLY



You have either reached a page that is unavailable for viewing or reached your viewing limit for this book.

FOR REFERENCE PURPOSES ONLY



You have either reached a page that is unavailable for viewing or reached your viewing limit for this book.

Table 23.1 Annual Summary of Air Quality for 1981

City	SPM	SO ₂	SR (sulphation rate) mg SO ₂ ... / 100 cm ³ /day	DF (dust fall) MT/km ² /month
Ahmedabad	217*	31*	0.10**	91**
Bombay	184	38	0.45	11
Calcutta	522	90 ^a	0.45*	34*
Delhi	433	31*	0.20*	31*
Hyderabad	143**	30**	—	—
Jaipur	308	6	0.18	19
Kanpur	432	13	0.19	34
Madras	155	8	0.33	—
Nagpur	199	12	0.22	34

*6-7 months average

**4-5 months average

a: scanty data

It can be seen from Table 23.1, that air pollution in many metropolitan cities in India, far exceeds the 150 mg per metre cube standard (for SPM) laid down by the WHO.

Wind roses, geographical features, and meteorology indicate the following observations in respect of these cities.

Bombay: The presence of active pollutants and discharges in the area can result in high atmospheric corrosivity.

Calcutta: The city can be classified as dusty.

Delhi: The commercial area is found to be more polluted as compared with other areas. High SPM values are recorded during the years.

Hyderabad: Air borne dust problems are indicated.

Jaipur: Natural dust due to frequent desert storms is the major source of high concentration of suspended particulate matter.

Kanpur: Air pollution problems can arise due to different wind patterns.

Madras: Air pollution problems can arise at active centres.

Nagpur: Ambient air quality is satisfactory.

23.3 National Scene

A conference on Air Pollution held at Bombay in 1982 revealed some interesting facts:

1. It was found that the lung capacity of children in the age group of 8-10 years was reduced by 20% in Nagpur due to pollution from manganese and power plants.

2. Effective pollution control measures can bring about metamorphic change. Chembur (in Bombay), which was once considered as 'gas chamber'

FOR REFERENCE PURPOSES ONLY



You have either reached a page that is unavailable for viewing or reached your viewing limit for this book.

FOR REFERENCE PURPOSES ONLY



You have either reached a page that is unavailable for viewing or reached your viewing limit for this book.

FOR REFERENCE PURPOSES ONLY



You have either reached a page that is unavailable for viewing or reached your viewing limit for this book.

FOR REFERENCE PURPOSES ONLY



You have either reached a page that is unavailable for viewing or reached your viewing limit for this book.

FOR REFERENCE PURPOSES ONLY



You have either reached a page that is unavailable for viewing or reached your viewing limit for this book.

FOR REFERENCE PURPOSES ONLY



You have either reached a page that is unavailable for viewing or reached your viewing limit for this book.

24.3.1 Indoor Pollution due to Burning of Traditional Fuels

About 50% of the world's households are using traditional fuels such as, firewood, animal dung, coke, etc., for cooking.

The common pollutants which cause indoor air pollution problems due to combustion of fuels are particulate matter, oxides of sulphur, oxides of nitrogen, carbon monoxide, hydrocarbons, and organic and odour causing chemicals. The emission quantity of these pollutants depends upon the type of fuel used, type of stove or furnace used, feed rate, amount of additional air and operating conditions.

In our country, over 80% of the time of housewives is spent in an indoor environment of which 4-6 hours is spent in kitchens for the purpose of cooking.

In order to determine the emission of sulphur dioxide and total suspended particulate matter during cooking, a short duration atmospheric survey was undertaken at the cooking place of low income houses, chosen randomly in different localities in the city of Lucknow. The survey was conducted by the Industrial Toxicology Research Centre, Lucknow. Coal, firewood and animal dung were being used in these houses for cooking purposes. It was found that emissions of sulphur dioxide and total suspended particulate matter in all the three fuels were much higher than the average annual standard for ambient air quality.

24.3.2 Indoor Pollution due to Pollens

Studies have revealed that pollens, fungal spores, and various types of dusts pollute indoor air, and cause allergic diseases, especially asthma. Further, studies have indicated that an environment around an asthmatic has an important role in triggering an attack of asthma. Pollens from trees, shrubs, herbs, grasses, and weeds causes allergy.

24.3.3 Indoor Pollution due to Artificial Building Materials and Poor Ventilation

Indoor air pollution, especially in new energy-efficient homes and offices, is making many people around the world sick. The hazard is becoming more serious with the growing use of man-made building materials, some of which emit harmful vapours and with energy conservation measures that reduce ventilation. In some advanced countries, the problem has become something of concern for citizens who have shockingly found that no official agency is in charge and no standards exist for control of indoor air pollution.

The most serious problems so far have been reported in new and remodelled office buildings and homes with energy-saving features, and in mobile homes. Most involve formaldehyde in construction materials, such as particle board and indoor plywood, and in urea formaldehyde foam insulation.

Formaldehyde vapours leak into the air when the temperature rises and

FOR REFERENCE PURPOSES ONLY



You have either reached a page that is unavailable for viewing or reached your viewing limit for this book.

FOR REFERENCE PURPOSES ONLY



You have either reached a page that is unavailable for viewing or reached your viewing limit for this book.

FOR REFERENCE PURPOSES ONLY



You have either reached a page that is unavailable for viewing or reached your viewing limit for this book.

AIR POLLUTION

A comprehensive book presenting the fundamentals of air pollution. The coverage includes the important principles and practices of pollution sampling, analysis and control. The types, sources and effects of air pollution on human health, animals, plants and materials are also dealt with in great detail. Also discussed is the part played by meteorological factors in dispersion of atmospheric effluents. Miscellaneous topics like acid rain, greenhouse effect, indoor air pollution and occupational diseases, such as silicosis and asbestosis, have also been covered.

An attempt has been made to make the book Indian-oriented. Included are the Pollution Control Acts of India, air pollution problems in Indian cities, Indian Standards pertaining to air quality, and specific case studies of effects of air pollution in India such as the effect on the Taj Mahal.

With its systematic approach, unified presentation and comprehensive coverage including data pertaining to Indian conditions, the book would be immensely useful to practising environmental engineers, civil engineers, chemical engineers, medical practitioners, and town and regional planners. It would also be useful to personnel in charge of pollution control in industries and government departments. Students would also find it an invaluable reference.

M N RAO is presently Professor-in-Charge, Technical Teachers' Training Institute, Extension Centre, Bangalore. He received his BE(Hons) degree in Civil Engineering from Andhra University in 1960 and MSc(Engg) degree in Public Health Engineering from Madras University 1961. He obtained his Ph D(Engg) from Burdwan University in 1969 and was sponsored as a Commonwealth scholar to the University of Auckland, New Zealand, for two years for post-doctoral work. He taught at Regional Engineering College, Durgapur for 16 years and later also worked as Manager (R&D) in environmental engineering with Suri and Nayar Limited, Bangalore.

Dr Rao is an active member of many professional bodies and societies. He is associated with the Board of Studies of nine universities. He is an expert member in many committees including the Technical Advisory Committee of Karnataka State Pollution Control Board, Bangalore.

He has published over 150 technical papers in Indian and international journals and has co-authored a book. He is the recipient of Nawab Jain Yar Zung Bahadur Memorial gold medals in 1968 and 1974.

H V N Rao is presently Reader in Civil Engineering at R V College of Engineering, Bangalore. He received his BSc degree from Mysore University and BE (Civil) and ME (Environmental) degrees from Bangalore University. He has a teaching experience of 20 years.

He is an active member of many professional bodies and societies like the Institution of Engineers (India), Institution of Public Health Engineers, Indian Association for Environmental Management, Indian Association for Air Pollution Control, and Indian Society for Technical Education. He has published many papers on various aspects of environmental engineering.

The McGraw-Hill Companies



Tata McGraw-Hill
Publishing Company Limited
 7 West Patel Nagar, New Delhi 110 008

Visit our website at : www.tatamcgrawhill.com

ISBN-13: 978-0-07-451871-7
 ISBN-10: 0-07-451871-2



9 780074 518717